

ORBITRON

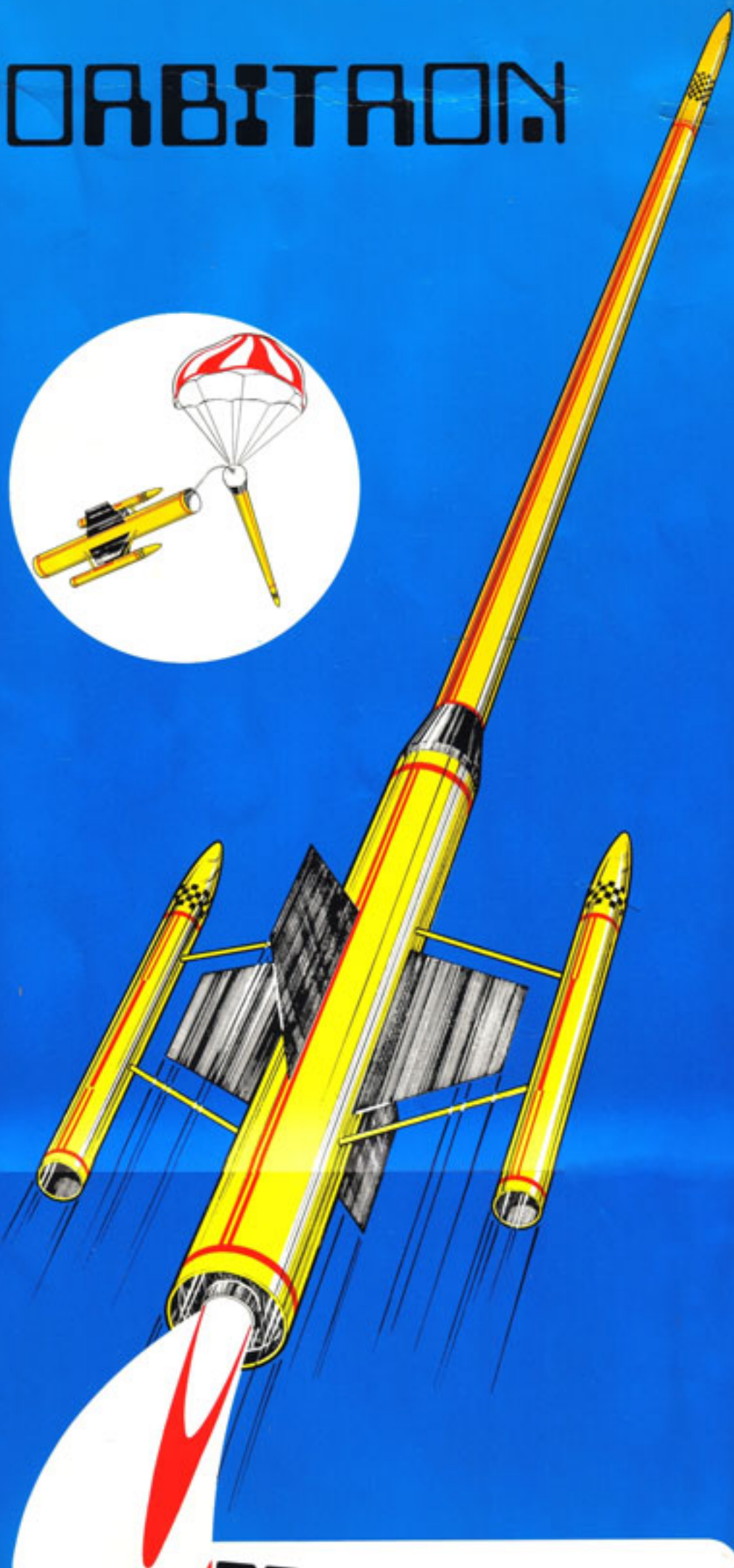

CANAROC

**FLYING SPACE MODEL KIT
MODELE REDUIT AEROSPATIAL**

SKILL LEVEL - NIVEAU DE COMPETENCE

BEGINNER	NOVICE	INTERMEDIATE	ADVANCED	EXPERT
1	2	3	4	5
COMMENCANT	NOVICE	INTERMEDIAIRE	AVANCE	SPECIALISTE

RECOMMENDED ENGINES
ENGINES RECOMANDES

SPECS

LENGTH 1075 cm (42.25")
LONGUEUR

DIAMETER 4.20 cm (1.66")
DIAMETRE

B2-2 C6-4
B4-2 C6-5
B6-2 D12-5

MANUFACTURED IN CANADA BY
FABRIQUE AU CANADA PAR

CANAROC INDUSTRIES LTD.
BOX 3275, EDMONTON, ALBERTA T5L 4J1

#DK-9

ORBITRON

ASSEMBLY INSTRUCTIONS

READ THESE INSTRUCTIONS CAREFULLY
BEFORE YOU START BUILDING

Additional materials and tools
required for construction:

- modelling knife or
single edge razor blade
- white glue
- fine sandpaper
- butyrate dope
- cornstarch or talc
- sanding block
- paint
- scissors
- ruler

Additional items required to
fly the Orbitron are:

- Heat Wadding
- Trans-A-Pad Launcher
- Countdown Controller
- Canaroc Engines
- Masking Tape

PARTS LIST

- | | |
|-----------------------------------|-----------------------------------|
| A) 1 - PT-400 Body Tube (40.6cm) | K) 4 - Centering Rings |
| B) 1 - PT-200 Body Tube (45.7cm) | L) 2 - Engine Retainers |
| C) 2 - PT-100 Body Tubes (21.1cm) | M) 4 - Dowels (13.3cm) |
| D) 1 - ET-200 Engine Tube (7cm) | N) 1 - Parachute (45cm) |
| E) 1 - ET-100 Engine Tube (7cm) | O) 1 - Shroud Line |
| F) 1 - CT-400 Coupler Tube | P) 8 - Tape Disks |
| G) 1 - BN-200C Nose Cone | Q) 1 - Shock Cord |
| H) 1 - BA-2040B Adapter | R) 1 - Launch Lug |
| I) 2 - BN-100A Nose Cones | S) 1 - Balsa Sheet |
| J) 2 - Centering Disks | T) 1 - Decal Sheet
(not shown) |

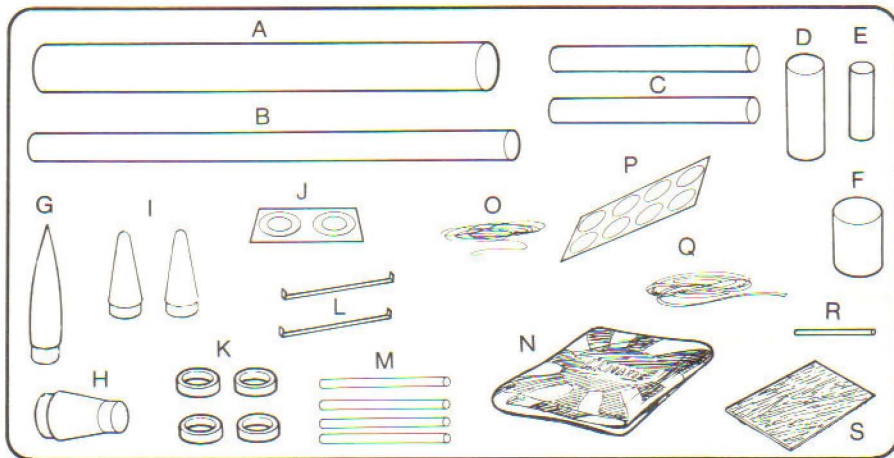

CONSTRUCT THE ENGINE MOUNT

A Cut a slit in the large diameter engine tube (ET-200) 7mm from one end (Fig. 1).

B Poke one end of the engine retainer into the slit. Put a double wrap of masking tape around the middle of the engine tube to hold the retainer in place (Fig. 2).

C Smear glue around the inside of the upper end of the engine tube, and slide one of the centering rings into place, sitting against the bent end of the retainer. This will act as a "fail-safe" engine block (Fig. 3).

D Glue a centering disk to one end of the coupler tube (Fig. 4). Cut a 5mm x 5mm notch from the remaining disk (Fig. 5).

E Slide the engine tube into the centering disk on the coupler tube, then slide the notched centering disk on the end of the engine tube and glue it into position on the coupler tube (Fig. 6). Center the coupler on the engine tube (leave the same amount of engine tube sticking out from either end). Apply a thick coat of glue to make a strong joint between the centering disks and engine tube (Fig. 7).

Fig. 1

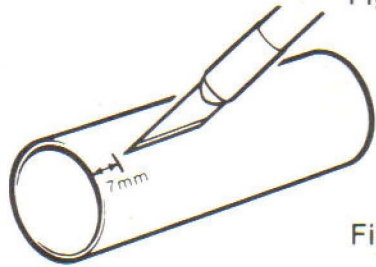

Fig. 2

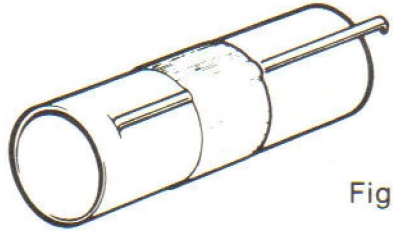

Fig. 3

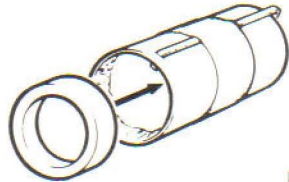

Fig. 4

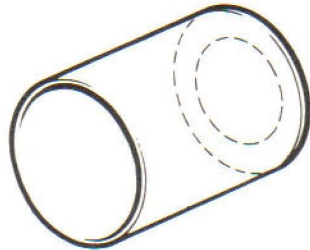

Fig. 5

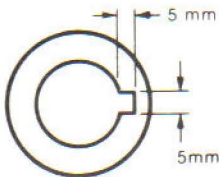

Fig. 6

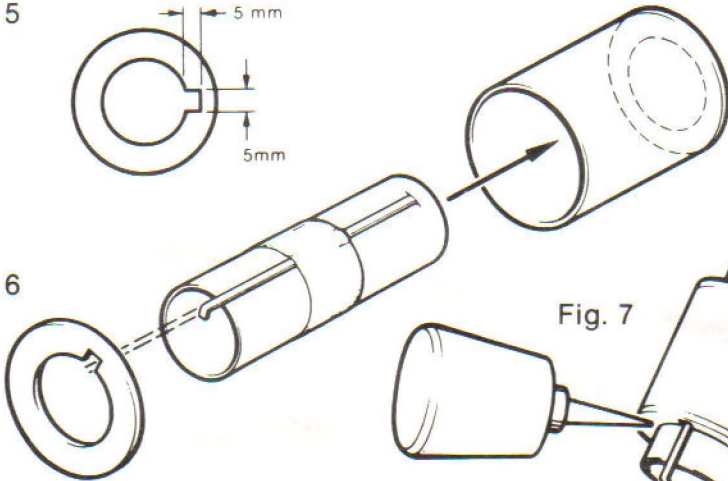
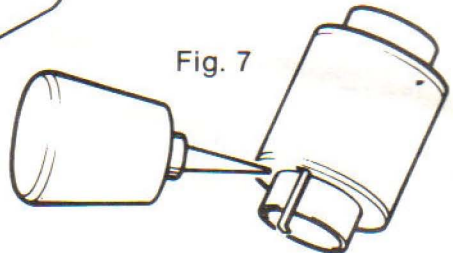

Fig. 7



CONSTRUCT THE ENGINE ADAPTER (for 18mm engines)

Fig. 8

A Cut a slit 7mm from the end of the small engine tube (ET-100). Push the end of the engine retainer into the slit.

B Test fit a centering ring to slide onto the tube, and over the engine retainer. If it will not slide on easily, then peel a layer of paper from the inside of the ring (Fig 8). Smear glue around the middle of the tube on the outside, and slide the centering ring over the retainer and onto the glue (Fig. 9).

C Glue a centering ring onto the front of the tube so that it is flush with the end (Fig. 10).

D Put a double wrap of masking tape around the engine tube between the two centering rings. This will help keep the retainer from being pushed forward.

E Cut a 5mm wide section from the last centering ring (Fig. 11). Smear glue around the outside of the tube at the rear, and slide the centering ring into place. Position it to be flush with the end of the tube.

NOTE: When the adapter is inserted into the engine mount to fly with 18mm diameter engines (C), the last centering ring will stick out of the tube. This is correct, as the ring's only function is to sit against the engine mount's retainer and prevent the adapter from moving.

MOUNTING THE OUTRIGGERS

A Cut out the Outrigger Template from the pattern sheet.

B Draw a lengthwise line down one of the outrigger tubes (PT-100), using a door or drawer sill as a straight edge. Make two crossed slits (Fig. 12) located 6.6 cm and 14.3 cm from one end of the tube along the line. Repeat for the other tube.

C Cut out the Fin Marking Guide from the pattern sheet. Wrap it around the center of the main body tube (PT-400) and place a

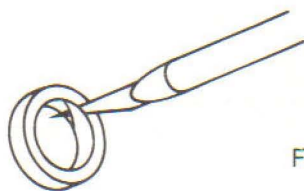

Fig. 9

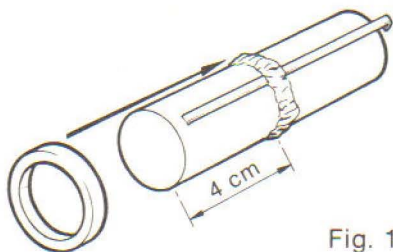

Fig. 10

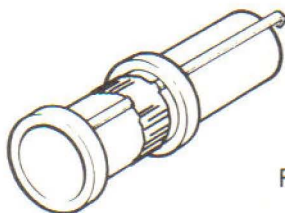

Fig. 11

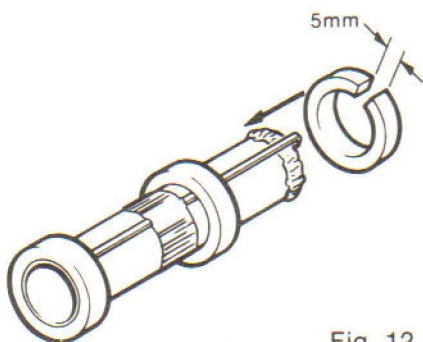
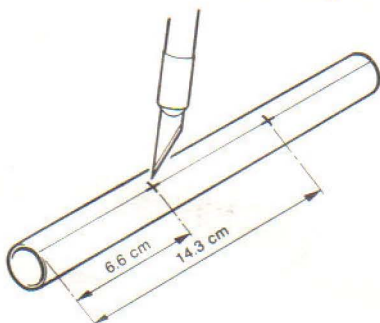

Fig. 12



pencil mark on the tube corresponding to each of the arrows on the marking guide.

D Draw lengthwise lines down the main body tube where the fin position marks were made using a door or drawer sill as a straight edge. On one of the lines cut two cross shaped slits located 14.5 cm and 26.5 cm from one end of the tube. Rotate the tube then cut two matching slits along the line exactly opposite to the first one.

E Take one of the dowels to be used as outrigger pylons, and lay it on the Pylon Cutting Guide on the pattern sheet. Using a razor saw (or other appropriate tool), cut the end of the dowel at the angle shown. Repeat from the other end **BEING CAREFUL THAT THE ANGLE IS PROPERLY ORIENTED** and the length is as shown in Fig. 13. Repeat for the other three pylons.

F Place a drop of glue on one end of a pylon, and push it through the cross shaped slits of an outrigger tube (PT-100). Repeat with another pylon, pushing it through the other cross shaped slits. Use the Outrigger Template to orient the angle of the pylons. Push the pylons until they seat against the wall of the outrigger tube (Fig. 14). **MAKE SURE THE ENDS OF THE PYLONS ARE ORIENTED AS SHOWN.** Set aside to dry. Repeat this procedure for the other outrigger.

G To mount the outriggers on the main tube, place a drop of glue on one end of each pylon, then push the pylons through the slits in the main body tube. Look down into the top of the tube and mate the pylon ends with each other inside the tube (Fig. 15).

Use the Outrigger Template to properly orient the angle of the outrigger assemblies (Fig. 16).

Fig. 13

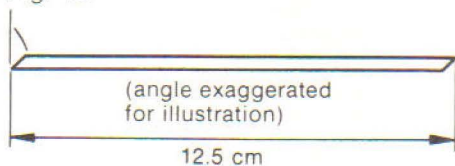

Fig. 14

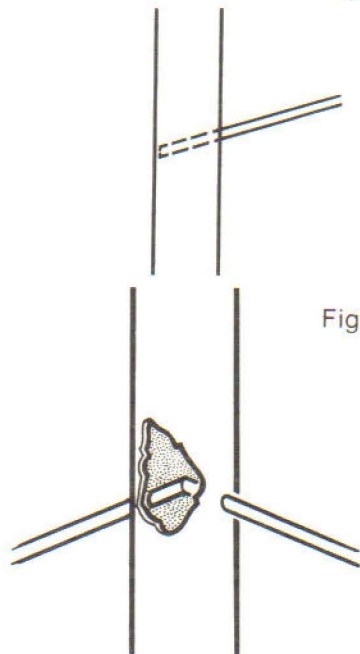

Fig. 15

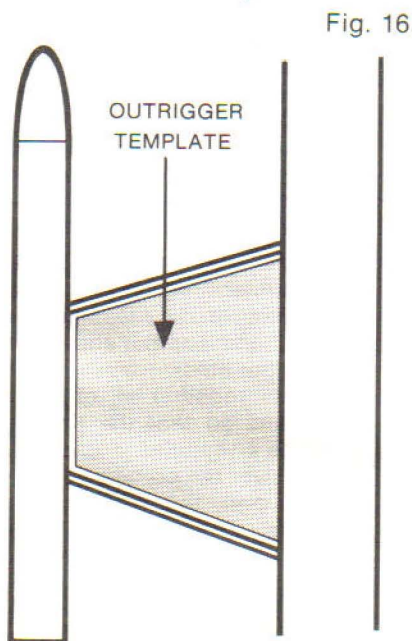
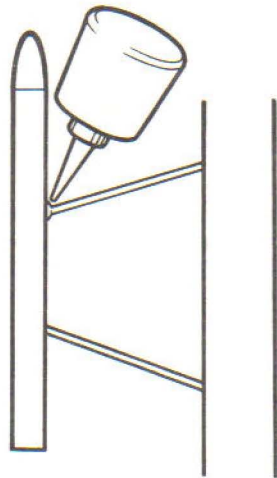

Fig. 16

H To strengthen the outriggers, apply a fillet of glue around the pylons where they go through the cross shaped slits on each tube (Fig. 17).

Fig. 17



CONSTRUCT THE FINS

A Cut out the fin pattern from the pattern sheet.

B Trace the pattern onto the balsa fin sheet. Make sure that the balsa grain direction is as shown on the pattern.

C Carefully cut out each fin from the balsa using a modelling knife or single edge razor blade. DO NOT ATTEMPT TO CUT THE Balsa IN A SINGLE STROKE. When cutting balsa, run the blade lightly along the line to be cut barely applying pressure on the first stroke. On each stroke afterward, apply more force on the blade. After three or four strokes, the balsa will have a smooth clean cut. Attempting to apply too much force and making the cut in one stroke will usually tear the balsa, giving the fin an unsightly appearance.

D To improve the appearance of the fins, round the leading edge and trailing edge of the fins (as shown in Fig. 18) by gently sanding with fine sandpaper or an emery board. Leave the fin tip flat, and squared off.

E The root edge of the fin, the edge that is attached to the body tube, must be perfectly flat if it is to have a strong joint when glued. Set a fin on the edge of a table, then wrap fine sandpaper around a block of wood. Hold the sanding block at right angles (90°) to the fin and sand the fin root in an up and down motion — very lightly (Fig. 19). Do this until the root edge is completely flat. Test to see if it sits flat by placing the root edge on a flat surface (such as a table top). Repeat for the other fins.

Fig. 18

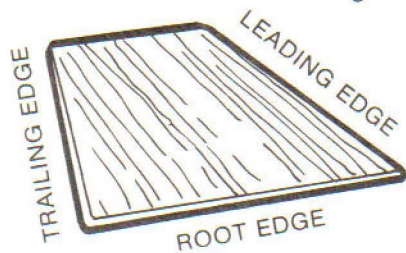
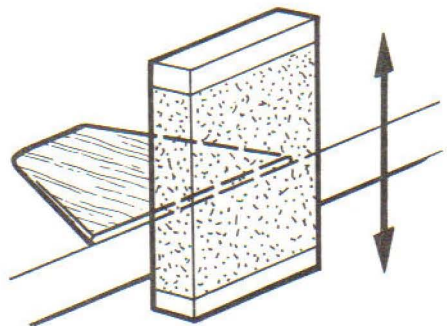

Fig. 19



FINISHING THE Balsa PARTS

Raw balsa is unsightly, coarse and grainy, if painted before the grain is "filled" and the surface is "sealed". Model rockets look professional if the time is taken to finish the balsa. The Canaroc Guide to Space Modelling contains tips on finishing and may be consulted for assistance.

Fig. 20

A The most common method of finishing balsa is using butyrate dope, available from most hobby outlets. To assist in filling the balsa grain, cornstarch, talc, or baby powder may be rubbed into the balsa and worked into the grain. Brush on a thick coat of dope, be sure to do both sides of each fin at the same time in order to avoid warping.

B After the dope dries completely, lightly sand the balsa surfaces with fine sandpaper. The sanding operation removes the excess thickness of dope and speeds up the process of filling the grain.

C After repeating the doping/sanding operation three or four times, the balsa grain should be filled and the surfaces smooth. The last sanding operation should be done with extra fine sandpaper.

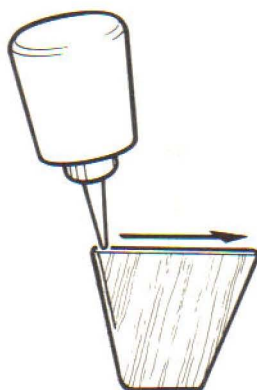
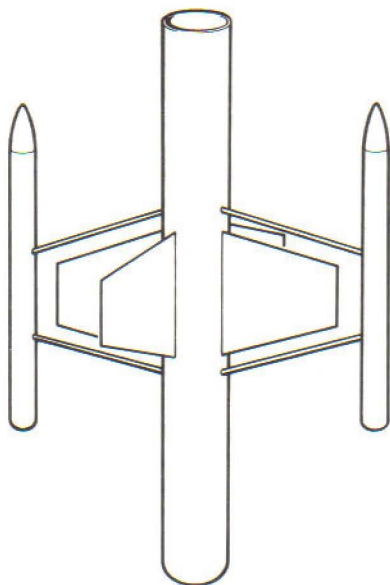

Fig. 21



ASSEMBLE THE MODEL:

MOUNTING THE FINs

A Place a line of glue along the root edge of a fin (Fig. 20). Place the fin on the tube along the alignment marks, halfway up the tube (Fig. 21). Be sure the fin is properly positioned with respect to the outrigger pylons. The fin should be the same distance from each outrigger pylon (2.0cm.). Set aside until the glue has set. Be sure that the fin sits at a 90° angle to the tube.

B Repeat the procedure to glue on the other fins. All fins should be evenly spaced around the tube when completed.

C Once all the fins have dried, lay a thin line of glue along each fin joint to form a "fillet" and strengthen the fin. Smooth out the line of glue neatly with the tip of a finger.

GLUE IN THE ENGINE MOUNT

- A Smear a wide band of glue around the inside rear of the main body tube, 2 cm up inside.
- B Slide the engine mount into the main tube until the coupler tube is 15 mm up inside the main tube (Fig. 22).

Fig. 22

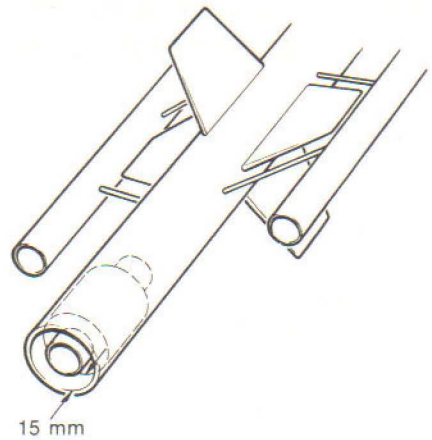

SHOCK CORD ANCHOR

- A Cut the shock cord anchor from the pattern sheet.
- B Construct the anchor as shown in Fig. 23. Fold the panels so that the shock cord folds with it.
- C Spread glue on the folded side of the anchor and insert it into the front of the main body tube at least 5 cm inside. Press it firmly against the wall of the tube (Fig. 24).

Fig. 23

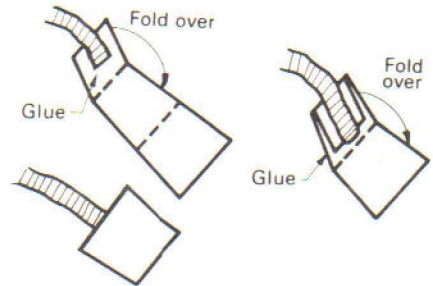

Fig. 24

ATTACHING THE ADAPTER

- A Pierce a hole in the eyelet with the modelling knife to attach shock cord.
- B Tie the free end of the shock cord to the eyelet and make a solid knot.
- C Trim off and sand smooth any flash along the seam of the adapter.

NOSE CONES

- A Roughen the shoulder of the nose cones with sandpaper. Glue in the outrigger nose cones.
- B Do not glue on the main nose cone or glue the upper tube to the adapter so that the model may be broken down for easy transport. However, the main nose cone and the adapter must fit tightly into the upper body to prevent separation at ejection. Tighten with masking tape if necessary.

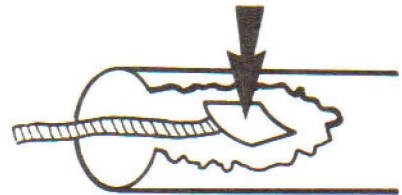

LAUNCH LUG

- A Glue the launch lug alongside one of the fin joints.

PARACHUTE

- A Construct the parachute using the instructions on the parachute pattern.
- B Take the knotted end of the parachute shroud lines and tie it to the eyelet in the base of the adapter.

PAINTING

- A Whether brushing or spraying, a base coat of white should always be applied. Paint should always be applied in thin coats to speed drying and prevent unsightly "sags".

B Final colors may be applied over the base coat when it has dried. Where necessary, masking tape may be used to separate colors. If spraying, cover the remaining areas with plastic wrap or paper.

C When spray painting, hold the can about 20 cm to 30 cm from the model, and spray in even strokes. Do not apply the paint too thickly or it will "run" and leave a "sag" in the surface. When brushing, be sure that the paint is not too thick, so that it may be properly brushed out and not leave brush streaks on the surface.

D When the final coat is dry remove masking tape by slowly peeling it back against itself, being careful not to peel off the base coat.

DECALS

To apply decals please follow the instructions on back of decal sheet.

FLYING

A Install the engine by sliding it into the engine tube until it is locked firmly between the two ends of the engine retainer wire. If the model is to be flown with 18mm diameter engines (B or C), then the engine adapter must be slid into the engine mount first.

B Push a piece of heat wadding down into the top of the tube. The wadding serves to protect the plastic parachute from melting by the hot gases of the engine's ejection charge. There should be about 3 cm thickness of wadding to create a good piston between the parachute and the engine.

C Fold the parachute in the following manner:

- hold the tip of the parachute with one hand and the shroud lines with the other.
- gather together all of the free corners so that the parachute forms a triangle.
- fold over the corners.
- fold over the parachute into thirds.
- wrap shroud lines around the bundle.

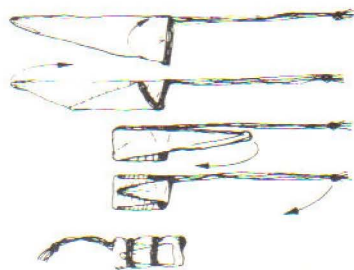

D Put the parachute, shock cord, and the remaining shroud lines into the tube, then slide on the nose cone.

E Install an igniter into the engine according to the manufacturer's instructions.

F Slide the rocket onto the launch rod, sliding the rod through the launch lug. This will guide the rocket at the moment of launch.

G Attach the igniter clips to the leads of the igniter.

H Insert the safety key into the launch controller, give a 5 second countdown and press the button to launch the model.

CANAROC



MANUFACTURED BY

IRWIN TOY LTD.
43 Hanna Avenue
Toronto, Canada
M6K 1X6

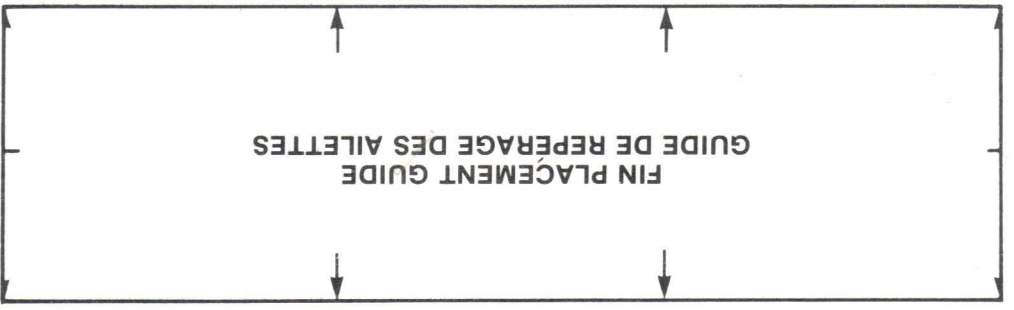

PYLON CUTTING GUIDE
GUIDE POUR LE DECOUPAGE DU PYLONE

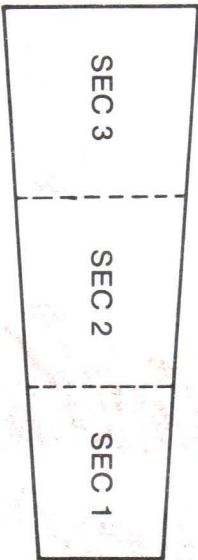
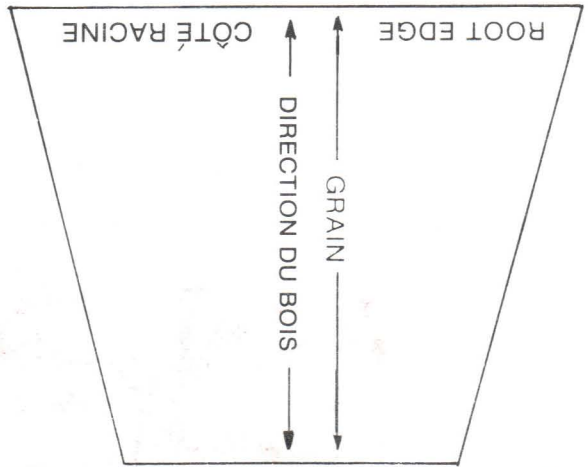
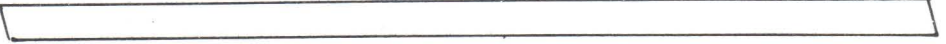

SHOCK CORD MOUNT
MONTAGE DU CORDON
AMORTISSEUR

ORBITRON #54008
PATTERN SHEET
FEUILLE - MODELE

ORBITRON

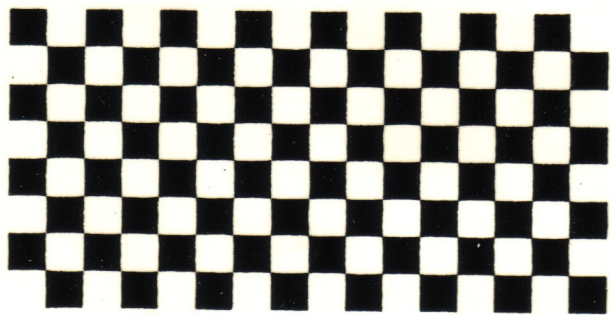
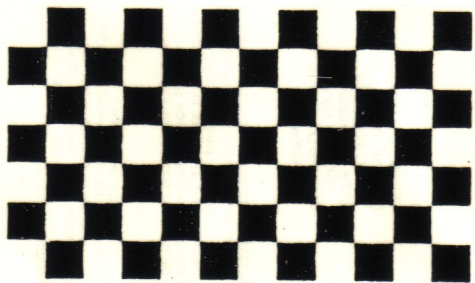
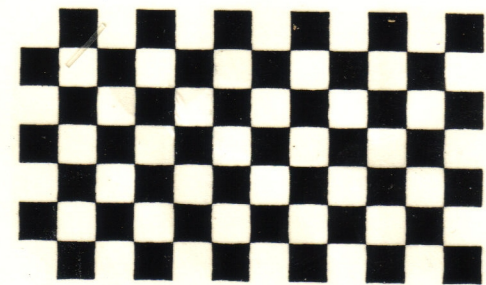

CANAROC

CANAROC