

SKY-LAB

ROCKET POWERED SPACE STATION



AN ADVANCED KIT!

NASA INSPIRED ORBITING
LABORATORY WITH:

CHROME SOLAR PANELS!
DOCKING COLLARS!
INSTRUMENT HOUSINGS!
ENGINE NOZZLES!
... AND MUCH MORE!

Catalog No. KB-4
Engines not included.

FEATURES:

DIE-CUT BALSA
CHUTE RECOVERY
HUGE DECAL SHEET
FORMED BODY
WRAPPER

SPECIFICATIONS

Length 24.50"
Body Dia. 2.04"
Net Wt. 3.40 oz.

RECOMMENDED ENGINES

B4-2 C6-3

Skylab kit requires contact
cement in addition to regular tools.

IP-466-0272

Centuri

FLYING MODEL ROCKET KIT

Centuri Engineering Co. Phoenix, Arizona

ENGINES

Igniters and complete engine installation instructions are included in "Engine Operating Instructions" which accompany all Centuri engines.

The SKY-LAB can be launched with the following engines:

ENGINE	APPROXIMATE ALTITUDE (feet)	PURPOSE
B4-2	200	For first test flights and medium sized launch areas.
C6-3	400	For higher flights and large launch areas.

FLIGHT PREPPING

1. Inspect shock cord and fastener for firm bond.
2. Insert Flameproof Parachute Wadding according to its directions.
3. Tuck in shock cord and rigging, being careful to avoid tangles.
4. Roll chute tightly as shown, and insert.

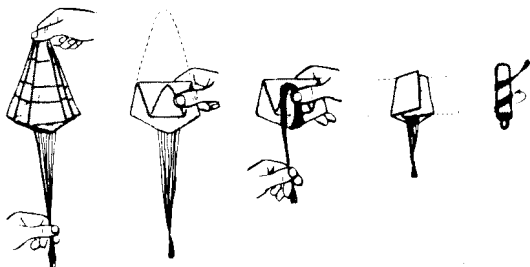

5. Socket nose section in place . . . fit should be snug, but not tight. Fit can become too loose, depending on weather conditions. If cone wobbles, apply a small piece of tape on the nose cone base.

6. Avoid letting rocket sit in hot sunlight for long periods as this may soften the adhesives.

Launch the SKY-LAB from any standard model rocket launcher having a 1/8" diameter x 36" long steel launch rod.

Referring to the specific instructions which accompany Centuri launchers and firing panels, mount the rocket on the launcher and prepare for ignition. Avoid eye injury by capping exposed tip of launch rod when not actually launching! Follow instructions and the Safety Code, and have many happy hours with Model Rocketry!



Expendable
Engine
Casing
Makes
A Handy
Safety Cap!



Centuri Engineering Co.
P. O. Box 1988
Phoenix, Arizona 85001

SKY-LAB

ROCKET POWERED SPACE STATION

The Centuri SKY-LAB is a unique flying model rocket design, inspired by the real NASA Sky-Lab concept shown on the enclosed sheet. The real Sky-Lab shape would not be aerodynamically stable in a flying model rocket. So we made a few changes to provide a flyable model that still has the "feel" of the real thing.

Every effort has been made to simplify the assembly of this advanced kit. The Centuri Sky-Lab is intended for modelers who have already built a few beginner rockets. It is certainly not beyond the ability of the average modeler who follows the carefully worked out instructions. Building the Sky-Lab is a rewarding project that will give you one of the most spectacular model rockets available.

This rocket is designed to be launched only from standard remote-controlled electrical launch systems. Always use the recommended engines and recovery wadding. Comply with all Federal, State and local laws.

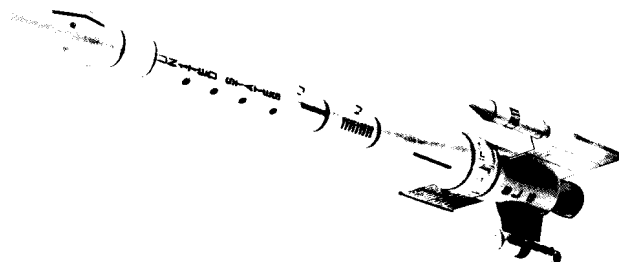

MODEL ROCKETEER'S SAFETY CODE

CONSTRUCTION

My model rockets will be made of only lightweight materials such as paper, wood, plastic, and thin metallic foils, with the exception of payloads and engine holders made of wirelike material.

ENGINES

I will use only pre-loaded factory made model rocket engines in the manner recommended by the manufacturer. I will not change in any way nor attempt to reload these engines.

RECOVERY

I will always use a recovery system in my model rockets that will return them safely to the ground so that they may be flown again.

WEIGHT LIMITS

My model rocket will weigh no more than 453 grams (16 oz.) at liftoff, and the engines will contain no more than 113 (4 oz.) of propellant, as prescribed by Federal Regulations.

STABILITY

I will check the stability of my model rockets before their first flight except when launching models of already proven stability.

LAUNCHING SYSTEM

The system I use to launch my rockets will be remotely controlled and electrically operated, and will contain a switch that will return to "off" when released. I will remain at least 10 feet away from any rocket that is being launched.

LAUNCH SAFETY

I will not let anyone approach a model rocket on a launcher until I have made sure that either the safety interlock key has been removed or the battery has been disconnected from my launcher.

LAUNCH AREA

My model rockets will always be launched from a cleared area, free of any easy-to-burn materials, and I will only use non-flammable recovery wadding in my rockets.

BLAST DEFLECTOR

My launcher will have a blast deflector device to prevent the engine exhaust from hitting the ground directly.

LAUNCH ROD

To prevent accidental eye injury I will always place the launcher so the end of the rod is above eye level or cap the end of the rod with my hand when approaching it. I will never place my head or body over the launching rod. When my launcher is not in use I will always store it so that the launch rod is not in an upright position.

POWER LINES

I will never attempt to recover my rocket from a power line or other dangerous places.

LAUNCH TARGETS AND ANGLE

I will not launch rockets so their flight path will carry them against targets on the ground, and will never use an explosive warhead nor a payload that is intended to be flammable. My launching device will always be pointed within 30 degrees of vertical.

PRE-LAUNCH TEST

When conducting research activities with unproven designs or methods, I will, when possible, determine their reliability through pre-launch tests. I will conduct launchings of unproven designs in complete isolation from persons not participating in the actual launching.

FLYING CONDITIONS

I will not launch my model rocket in high winds, near buildings, power lines, tall trees, low flying aircraft or under any conditions which might be dangerous to people or property.

909,258

ASSEMBLY INSTRUCTIONS

SET THE EXPLODED VIEW NEAR YOU TO REFER TO WHILE ASSEMBLING THE SKY-LAB

TOOLS; In addition to the parts supplied, you will need the following standard model rocket tools to assemble and finish this kit. **DO NOT** use model airplane glue for building flying model rockets.

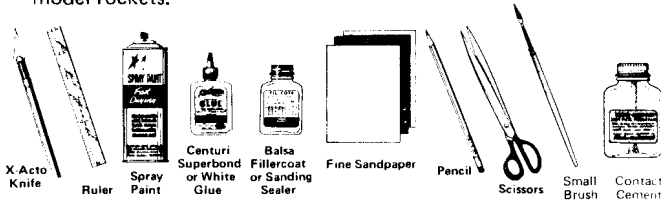

- 1** Compare the sheet of die-cut paper discs in your kit to the illustration below to identify each part. These will be used later on in various steps.

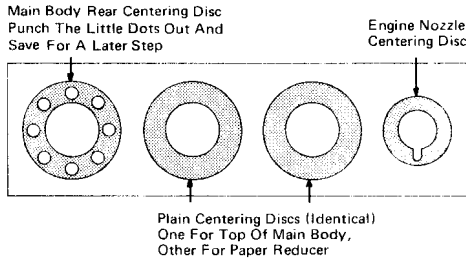

- 2** Smooth inside edges of main body tube with your thumbnail. Apply bead of glue around inside edge of tube and snap over the rear body centering disc . . . the one with little holes. Repeat with other end of tube, using one of the plain centering discs. Set this main body assembly aside to dry.

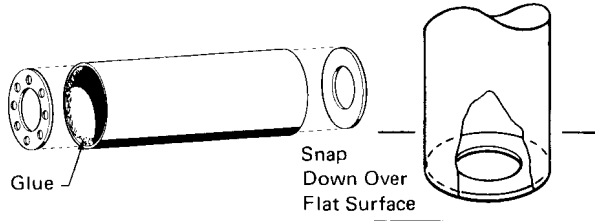

- 3** Remove the bell nozzle and nozzle rim carefully from their vacuum formed sheet. Run each piece upside down over fine sandpaper to remove the flat center areas. Glue rim onto nozzle with contact cement or plastic glue . . . whichever you prefer.

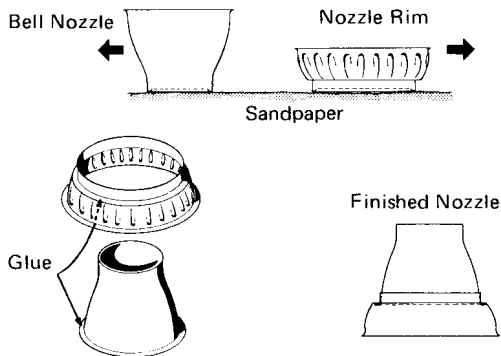

- 4** Run a generous bead of glue around the inside end of one "boom" body tube. Insert the Black coupler about halfway, with a turning motion. Allow glue a moment to set, and repeat with the other "boom" body tube to complete joining tubes. Roll along table top to be sure tubes are aligned.

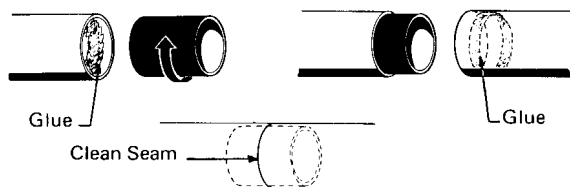

- 5** Cut out the paper reducer carefully. Pre-curl the paper (with shiny surface outside) by running it under a straight edge on a clean, flat surface. Curl paper carefully and gradually so as to prevent creases from forming.



- 6** Form the paper into a cone and apply thin film of glue on the overlap area marked on the reducer. Be careful not to smear glue on the exposed part of the paper. Line up the edge of the paper with the dotted line and press together on a flat surface. Hold for a moment while glue sets.



- 7** Run a thin bead of glue around the inside edge of the larger end. Lay the remaining plain centering disc on the table and gently press the shroud down over it, until the ring nestles in place. Set this paper reducer assembly aside to dry.

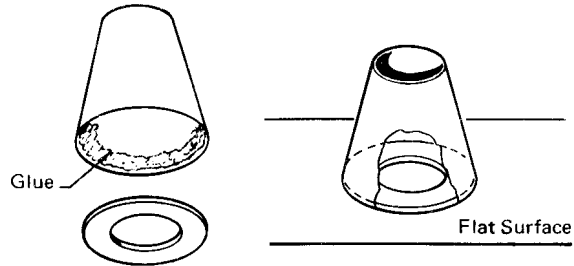

- 8** NOTE: There are three seemingly identical #7 tubes about the size of a model rocket engine. Select the one with a small pre-cut slit in one end and save the others for a later step.

Slip one end of the engine lock into the engine tube slit. Run a bead of glue around the inside of the engine tube and insert thrust ring until it butts against the engine lock.

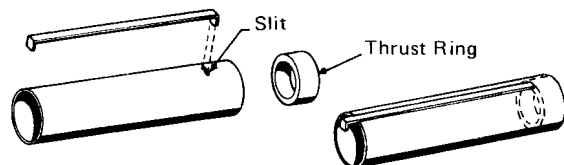

- 9** Slide the previously assembled plastic nozzle gently onto the engine tube, starting at the thrust ring end. Position so bottom of nozzle is flush with rear of engine lock. Be sure engine lock is aligned parallel with tube.

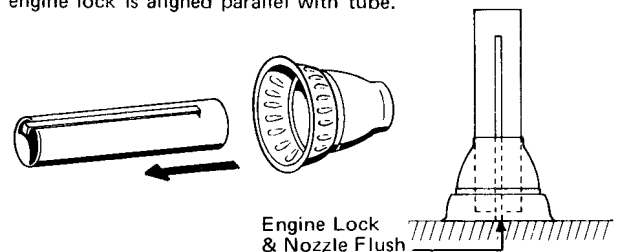

- 10** Push the die-cut engine nozzle centering disc in place and secure with a bead of glue. Run a bead of glue around engine tube just above plastic nozzle and slide engine centering tube in place.

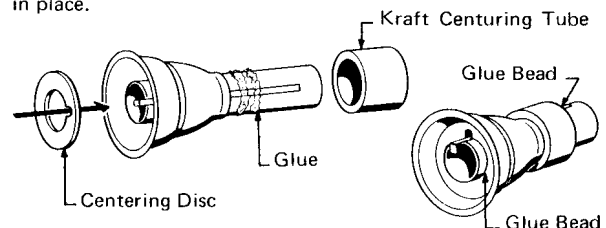

- 11** Stand the main body tube on the fin guide to mark fin locations. Find a convenient channel or groove, such as a door jamb, partially open drawer, or moulding. Extend the marks the full length of the tube.

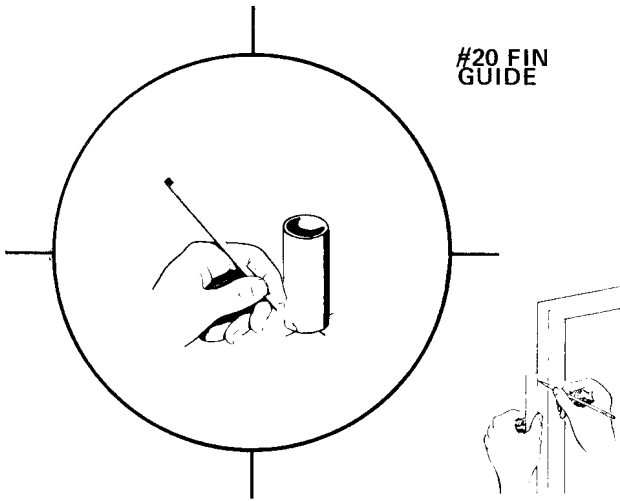

- 12** Slide the main body tube assembly onto the "boom" body tube assembly to position shown. Apply a bead of glue at each end, and smooth into neat fillets. Be sure the disc with holes is at rear end.

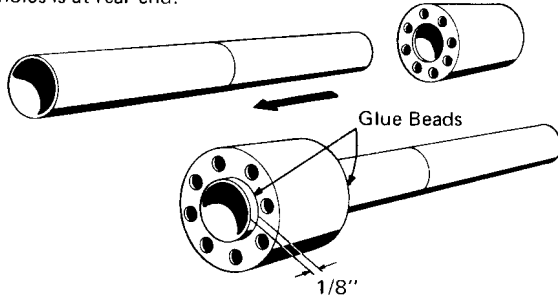

- 13** Carefully push the die-cut Balsa parts from their sheet. Start at one point on each piece and work gently around. Use a knife, if necessary, to avoid ragged edges. Save all pieces, as they will be used later on in various steps. Asterisks indicate decorative instrument tunnels.

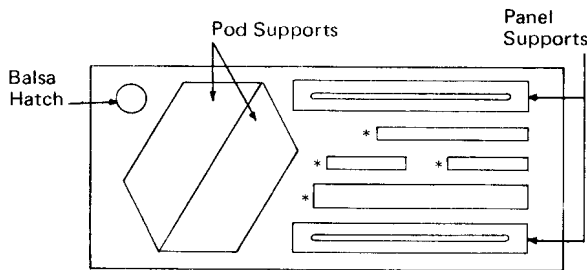

- 14** The panel supports (strips with slots running through them) need to be sanded and trimmed before gluing onto model. Run these pieces over fine sandpaper wrapped around the main body, to obtain the proper curved underside . . . be careful not to break them. Cut each end, with a sharp knife, to a bevel as shown.

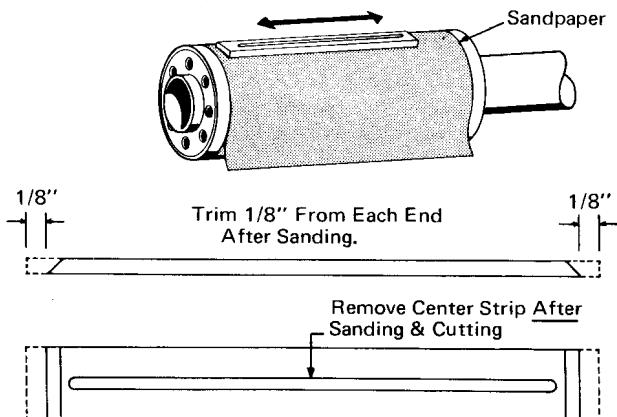

- 15** Glue in place, centering each strip along opposing drawn lines, at extreme rear of main body tube. Tape or hold in place until glue starts to set.

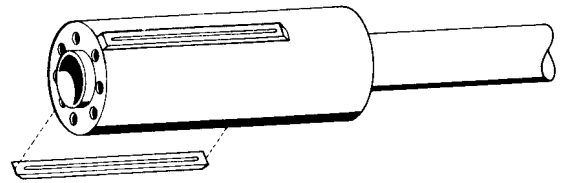

- 16** Smooth the surfaces and edges of pod supports with fine sandpaper. Apply glue to the root edges of the pod supports and press in place on the drawn lines. Remove and allow glue a moment to become tacky. Apply fresh glue to each and reposition on body, checking alignment visually. Allow to dry, standing assembly upright.

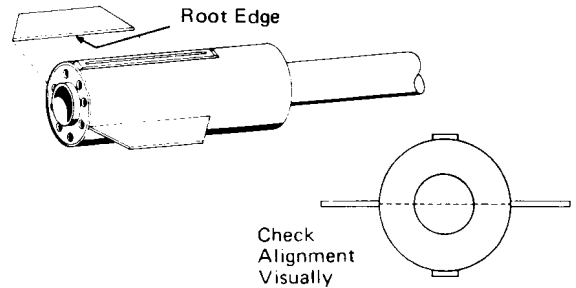

- 17** Peel the backing from a pressure-sensitive tab and apply tab firmly on base of one of the pod cones. Smooth inside edge of a 3" pod tube with thumbnail to remove any burrs. Apply glue inside tube and insert cone with a firm, even twisting motion. Repeat with remaining tube and cone. The paper tabs allow for plastic gluing with ordinary model rocket glue.

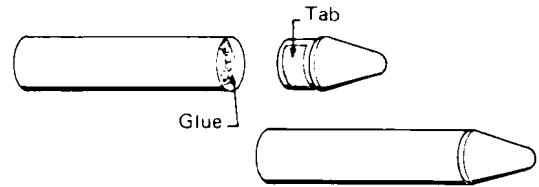

- 18** Draw an alignment line along each pod tube, like you did with the main body tube. Glue the assembled pods onto pod supports. Again, check alignment visually.

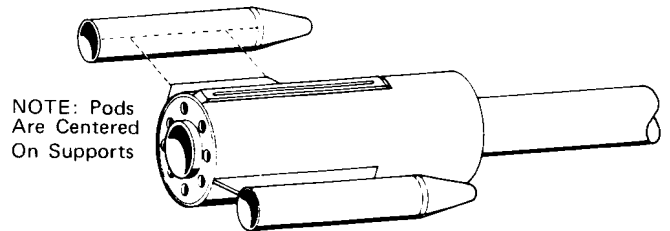

Check Alignment

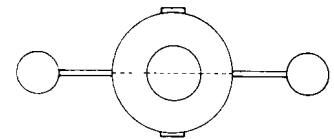

- 19** There are three "launch lugs" in your kit. Two are used decoratively as tip-tubes on the solar panels. Run a bead of glue along any one edge of a solar panel and apply a tip-tube. Repeat with other panel and allow a moment to dry, maintaining neat alignment.

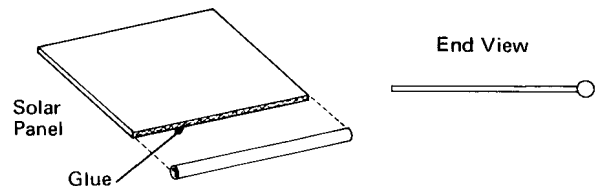

- 20** Run a bead of glue down into each panel support's slot, and glue panels in place. Check alignment again, and allow entire assembly to dry standing upright for several minutes.

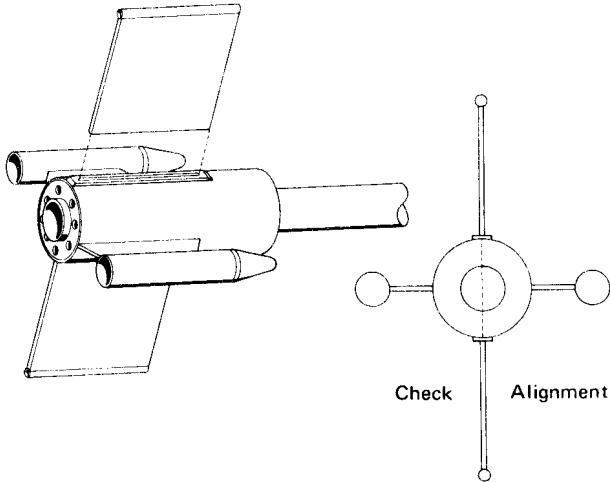

- 21** When assembly is dry enough to handle, test-fit reducer assembly down over "boom" tube to be sure it can slide past the tubes' joint. Remove reducer, apply glue beads as shown, and reassemble. Wipe away excess glue and hold assembly until glue starts to set.

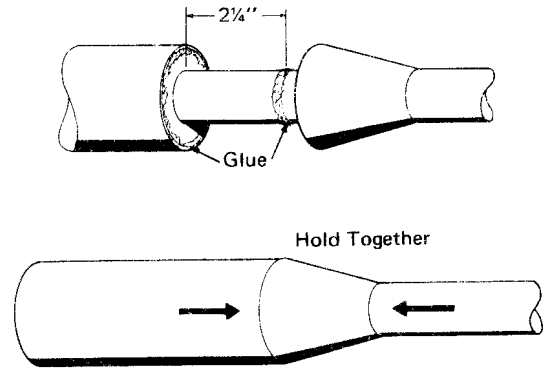

- 22** The die-cut balsa strips indicated with asterisks back in step 13 are decorative "instrument tunnels" to be glued on as shown below. For the neatest appearance, bevel the ends and sand the undersides round as you did earlier with the panel supports. Hold each piece in place until glue sets.

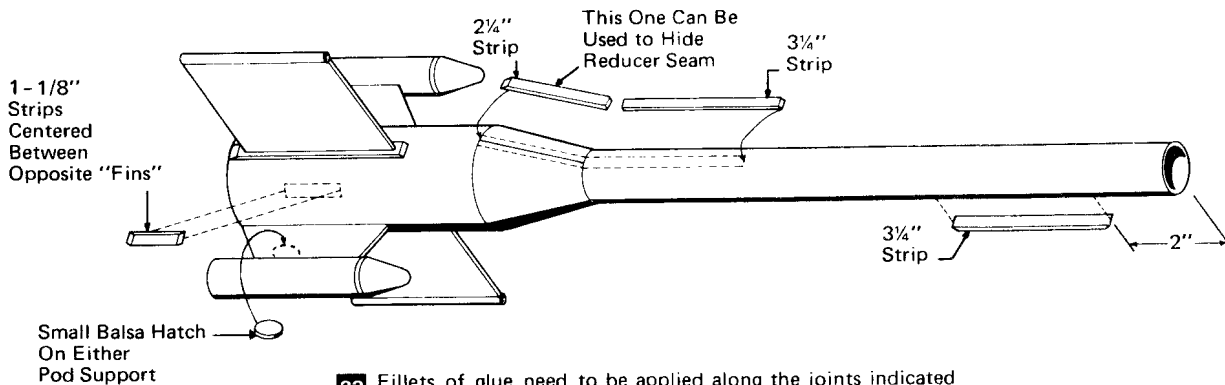

- 23** Fillets of glue need to be applied along the joints indicated below, for neat appearance and durability in flight. Apply a bead of glue around the base of each piece and smooth into neat fillets with your finger.

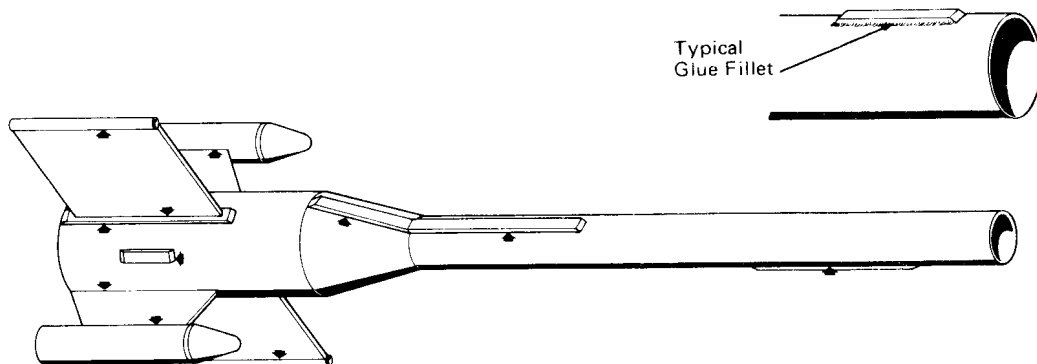

- 24** Contact cement is a commonly available glue that will permanently bond the plastic vacuum formed wrapper, nozzles, etc. to the rocket. Some types of spray-cement work well, also.

If used incorrectly, it can damage the plastic parts! Study these tips before gluing on the parts as explained in later steps.

FIRST: Experiment with some of the "scrap" plastic (the sheet holding all the parts together).

- a. Be sure you have the parts turned face down before applying cement.

- b. Brush cement on evenly over the back of the parts, making sure you have cement along all edges.
 c. Do not brush cement into the detail depressions of the parts.
 d. Apply cement to the body tubes exactly in the area where the parts will be applied.
 e. Allow the cement to dry completely before attaching the parts.
 f. Position the parts exactly before allowing them to touch the body tubes.
 g. Smooth the parts onto the tubes with a firm, even pressure.

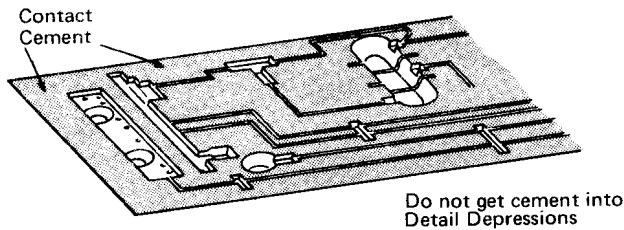

- 25** Wrap the instrument wrapper around the uppermost part of the body tube with each end beginning and ending midway between two fins. Draw a line around the tube along the bottom edge of the wrapper. Cement the wrapper on, following tips in step 24.

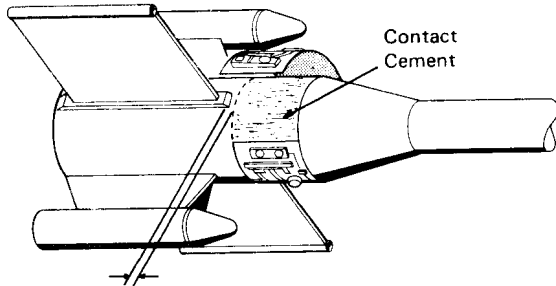

NOTE: There should be at least 1/8" space between wrapper edge and panel. Trim Panel Support if necessary.

- 26** The four plastic access hatches are to be contact cemented onto the "boom" body tube at various places. Bend them gently first, to conform to the body tube curve, and position the hatches neatly. Likewise, cement the long plastic instrument tunnel in place on the top part of the "boom", opposite the previously glued wooden tunnel. Hold each piece in place until cement sets.

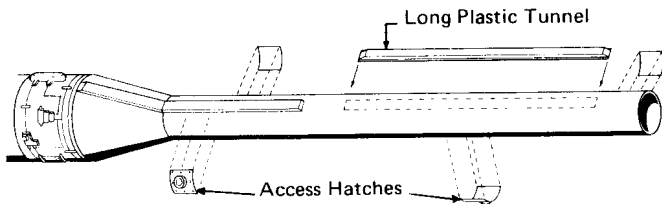

- 27** Contact cement the nozzle bases into the pod tube's open end. Push one of the little dots (scrap from the main body rear centering disc) into the little depression in each nozzle base. This will protect that area from paint later, so you can easily glue the nozzles on in one of the final assembly steps.

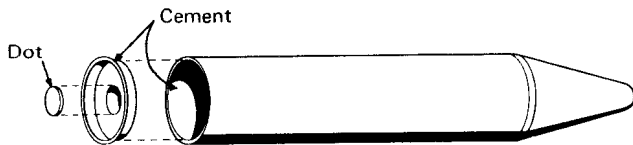

- 28** The docking collars will be cemented into the "boom" body in line with each other on the opposite side of the plastic tunnel. Mark the positions with a pencil, and carefully cut neat 1/4" holes for the back of the collars to be cemented into. This technique will strengthen the cement joint, and provide durability in flight.

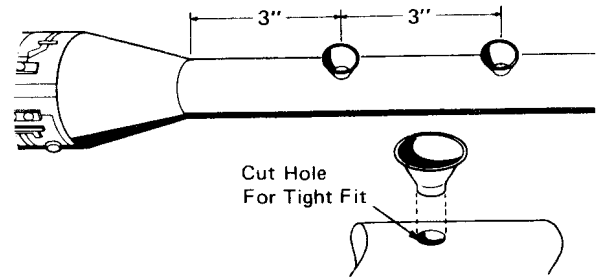

- 29** The remaining 3" long launch lug will be cut in two as shown. Use a sharp knife, to avoid crushing the lug! Glue the lug onto the main body where the two ends of the wrapper almost meet. Save the "turbine exhaust" for next step.

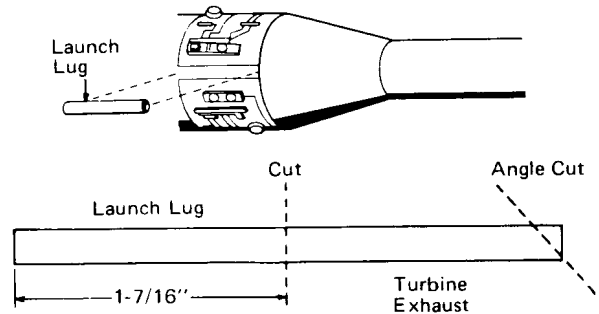

- 30** Apply glue around the rim of any one of the holes in the rear centering disc and around the forward end of turbine exhaust. Insert turbine exhaust through hole about 1/2" and hold in angled position until glue starts to set.

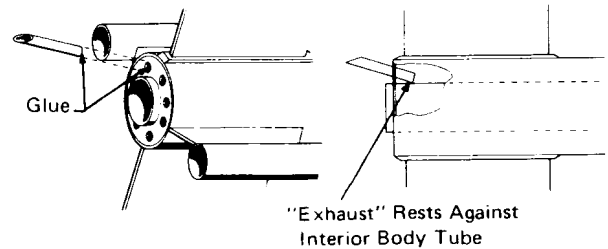

- 31** All of the balsa wood (pod supports, panel supports and decorative strips) need their surfaces sealed for best appearances.

Fill the wood grain with Centuri fillercoat or sanding sealer. When dry, sand with fine grain sandpaper. Repeat until smooth, but be careful not to sand body tubes.

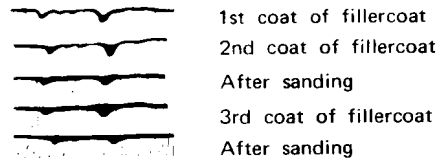

- 32** NOTE: The roll of 1/16" wide tape included in this kit will be used decoratively two ways: Some of it will be applied to the unpainted model, in the next step. Later, after the model is painted, the applied tape will become white like the model, and give an interesting surface "relief" that simulates sheet metal ribbing or reinforcement. The remaining tape will be applied on the painted model, along with decals, in the final steps.

- 33** There are about 125 inches of tape on the roll, which should be more than enough. Try to use no more than about half of the tape (62 inches) in this step, and save the other half for the final trimming.

Apply the tape firmly and neatly, using your imagination and the suggested guide below. For best appearance, tape should be applied in straight lines along axis, and around circumference. Tape should not cross over "tunnels" or other decorative surface features.

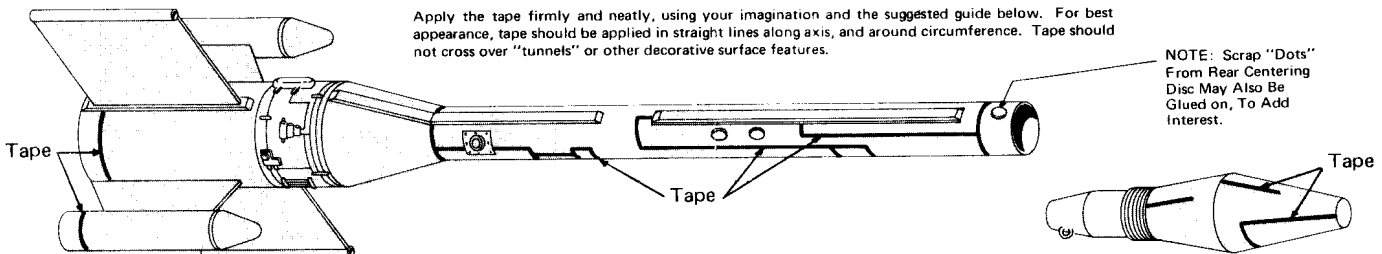

34 When spraying plastic parts, never use dope or lacquer! First spray with an enamel primer suitable for plastic.

Spray painting your finished model with a fast-drying enamel will produce the best results . . . IF IT IS DONE PROPERLY!! Most important is the number of coats of paint. DO NOT try to paint your model with one heavy coat! Instead, give it a couple of quick, light coats first and then a finish coat. Let each coat dry before applying the next.

**SPRAY PAINTING
TYPICAL MODEL
ROCKET**

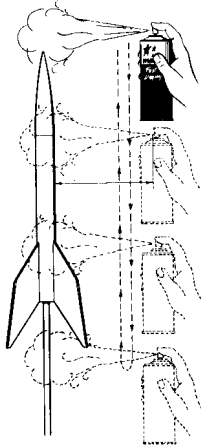

35 Socket nose cone in place and spray entire model either flat white or glossy white. Flat white gives "scale" appearance, but picks up dirt easily . . . glossy white is more durable.

Mask the pod nozzle ends as shown below and spray with primer or white.

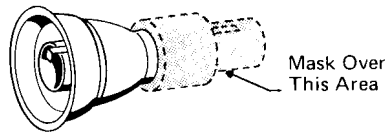
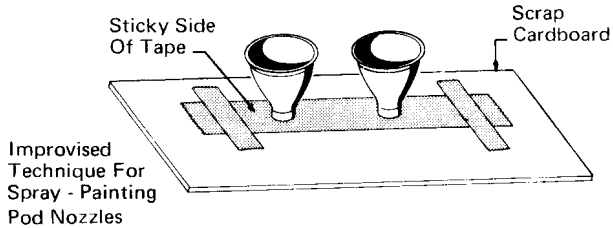

36 When the primed nozzles are dry, spray with SILVER paint. Paint the tip tubes and turbine exhaust BLACK OR RED, using a small brush.

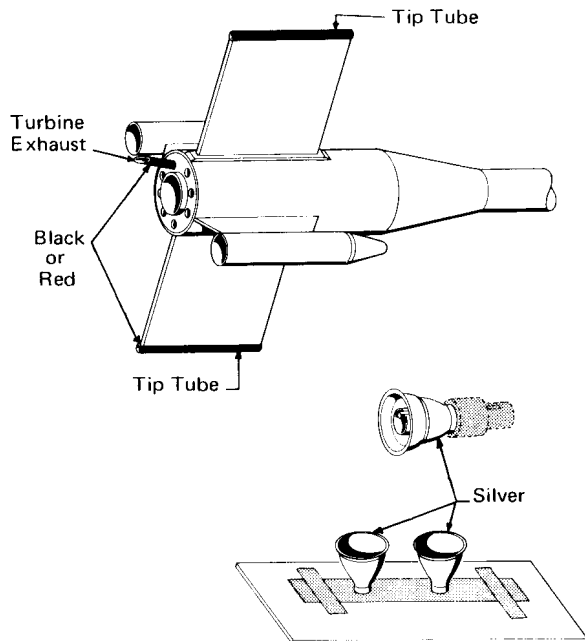

37 When tip tubes are dry, prepare to apply embossed chrome foil onto solar panels. Remove any noticeable surface imperfections from the cardboard panels. Check fit of foil. Trim, only if necessary. Peel the backing from the foil, taking care not to touch adhesive any more than necessary. Apply foil, starting from bottom of panel, and work gently forward. Bend tightly over leading edge and smooth neatly into place on reverse of fin. Trim off any excess that may hang over rear of panel. Rub down firmly, especially leading edge, to remove air pockets.

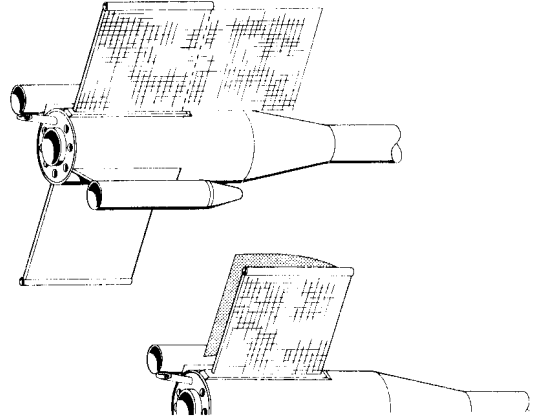

38 Remove the little paper dots from the pod nozzle bases. Test-fit the nozzles in place. NOTE: If any paint has accidentally gotten on either surface where they join, scrap away the paint to provide a good gluing surface. Glue the nozzles in place, with contact cement or plastic glue.

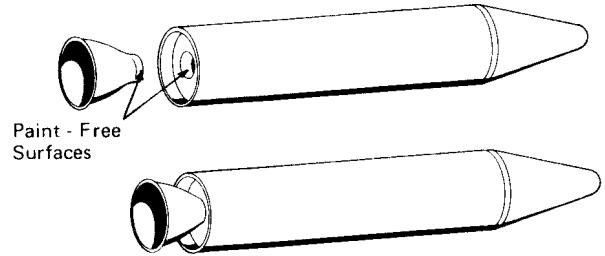

39 Apply a generous bead of glue inside rear "boom" tube of the model, and a thin film of glue around the engine mount's centering tube. Insert with a firm turning motion until rear of centering tube and "boom" tube are flush. Allow model to dry standing upright.

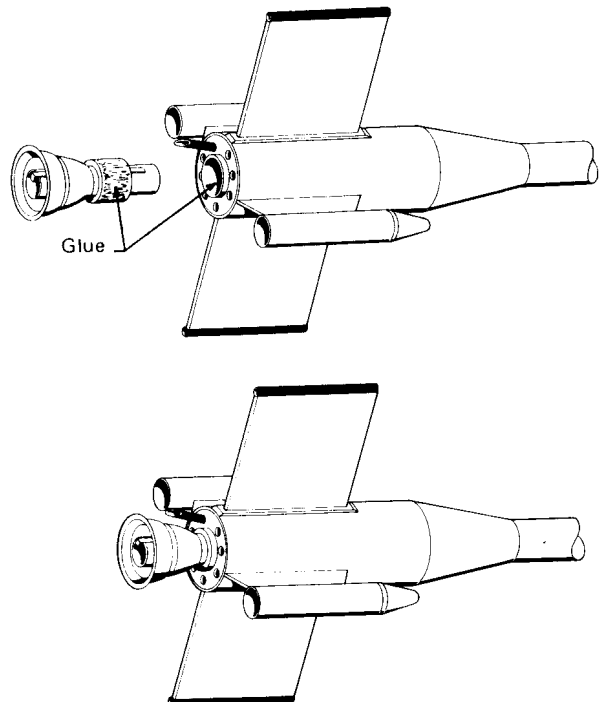

40 NOTE: The recovery system must be attached in a manner that will prevent the plastic nozzles from hitting the ground first, as the rocket descends on its parachute. Read over the two methods below and decide which you

want to use. The solid lines indicate the shock cord, and dotted lines indicate the rigging string – cut to length. If you have any doubts about rigging and prepping the horizontal technique, use the easier vertical one.

A. VERTICAL SUSPENSION

Fairly easy to do . . . When descending, the rocket will hang nose first, thereby minimizing damage to the plastic nozzles.

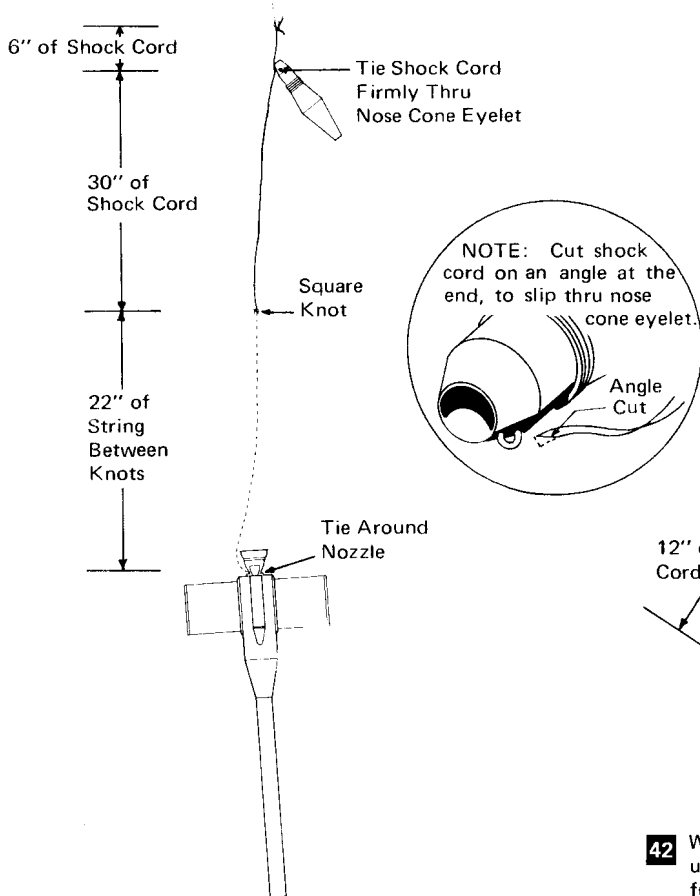
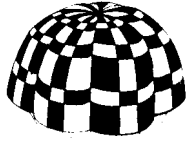

B. HORIZONTAL SUSPENSION

More challenging to rig, but it will allow the rocket to descend in a horizontal "flying" position . . . very graceful for demonstration flights.

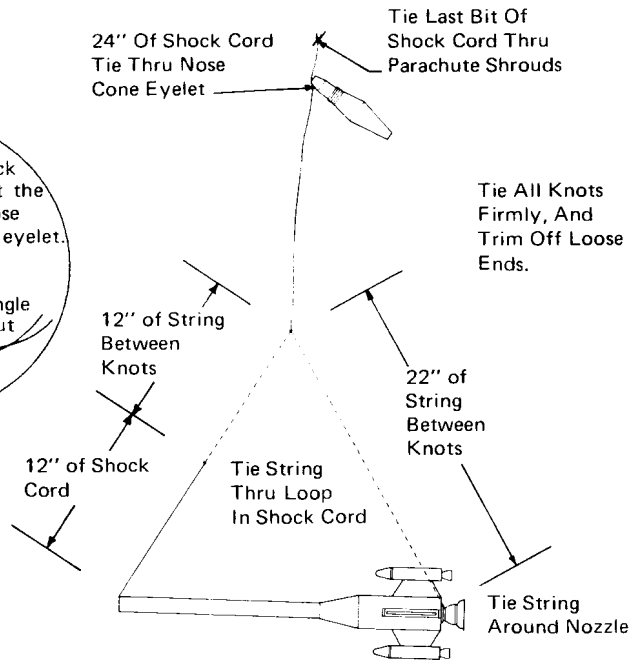

41 NOTE: This step is necessary if you use the "Horizontal Suspension". Skip to next step if you use the "Vertical Suspension".

The 12" shock cord is held in the forward part of the "boom" tube in this manner:

Peel the backing from the fastener. Thread one end of the elastic shock cord through the fastener as shown. Take care not to touch the adhesive backing any more than absolutely necessary. Slightly crease the fastener lengthwise to allow easy insertion into tube.

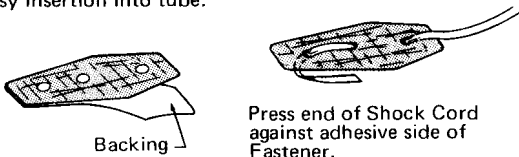

Insert the fastener 2" past the top of the "boom" tube. Press firmly against the inside wall of the tube with a finger or eraser end of a pencil. NOTE: All edges of the fastener must be firmly contacted to the tube to insure a permanent bond.

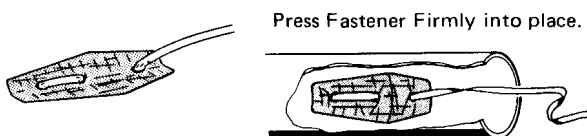

42 With either technique the rocket will have the string running up its side and down into the top of the "boom" tube, when fully prepped. The string may be untied from the nozzle for displaying the rocket.

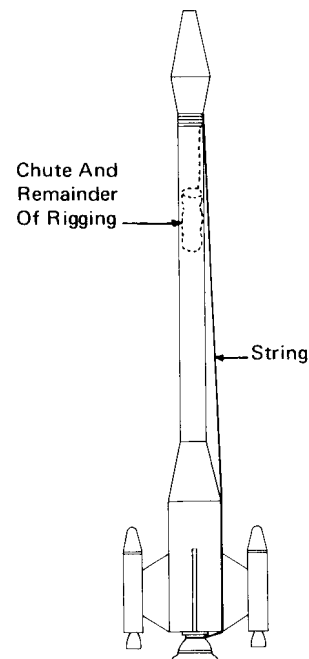

43 APPLY THE REMAINDER OF THE 1/16" WIDE TAPE AS SHOWN BELOW.

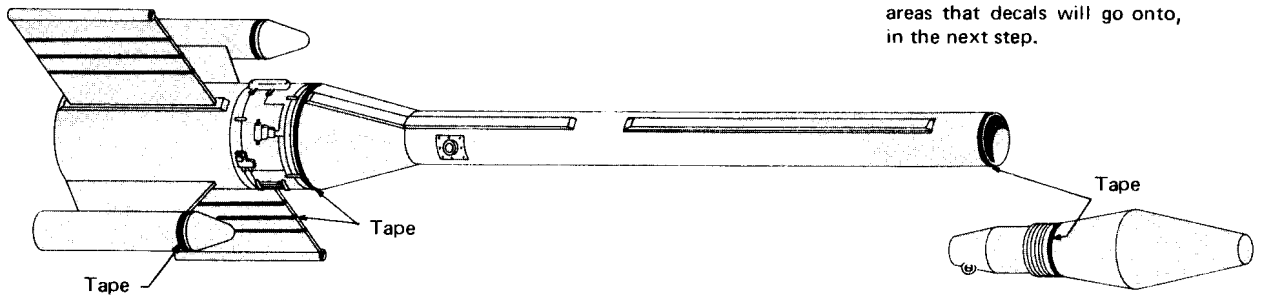

Try not to apply tape in the areas that decals will go onto, in the next step.

44 Read the decal application instructions on the back of the decal sheet. Hold the sheet at various angles to see how the decal images are on clear, separate "islands". Cut them apart carefully and apply as shown below. Use your imagination, and as much as possible, try to avoid placing decals over the previously applied 1/16" tape. Allow decals to dry thoroughly before launching.

NOTE: Some of the previously applied detail has been omitted for clarity.

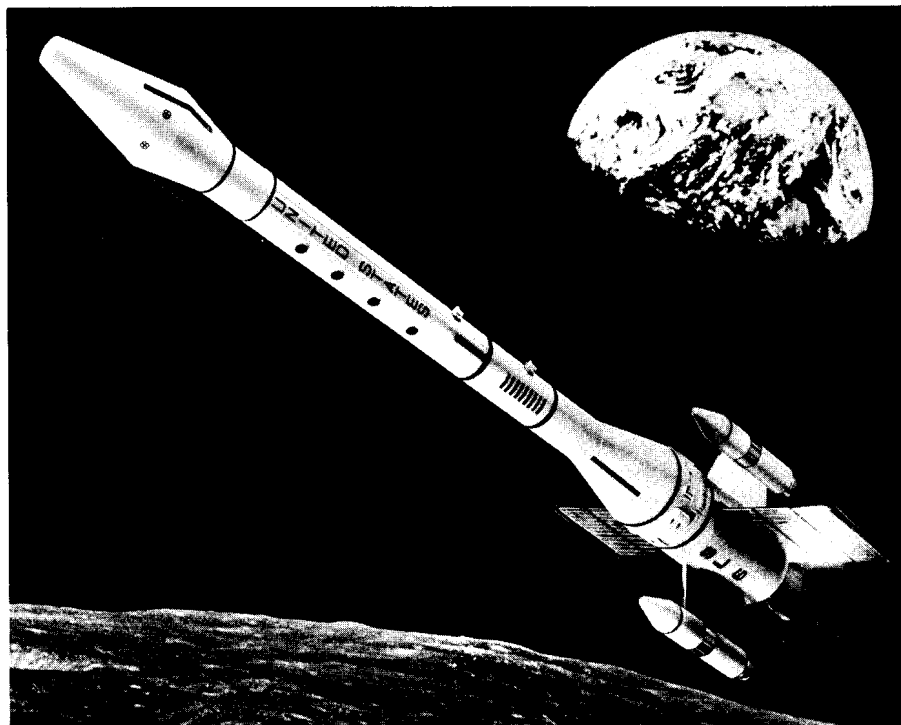
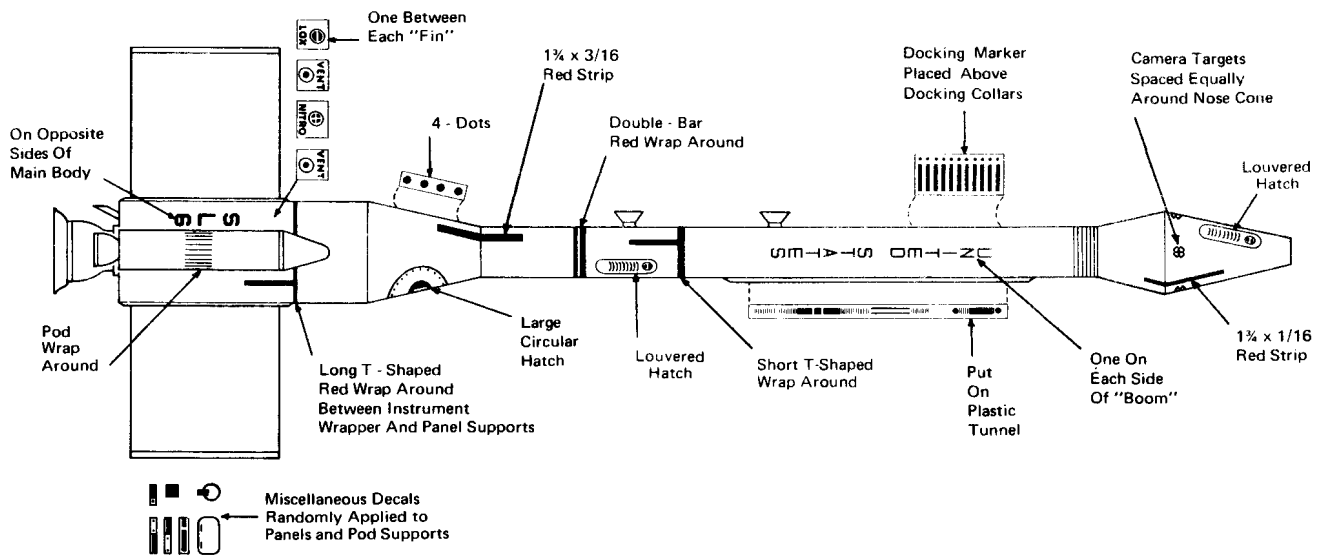

Reprinted Courtesy Of National
Aeronautics And Space Administration
INK RENDERING BY MERVIL B. SEALS FROM BLUEPRINT COURTESY
OF MARTIN MARIETTA CORPORATION - DENVER DIVISION

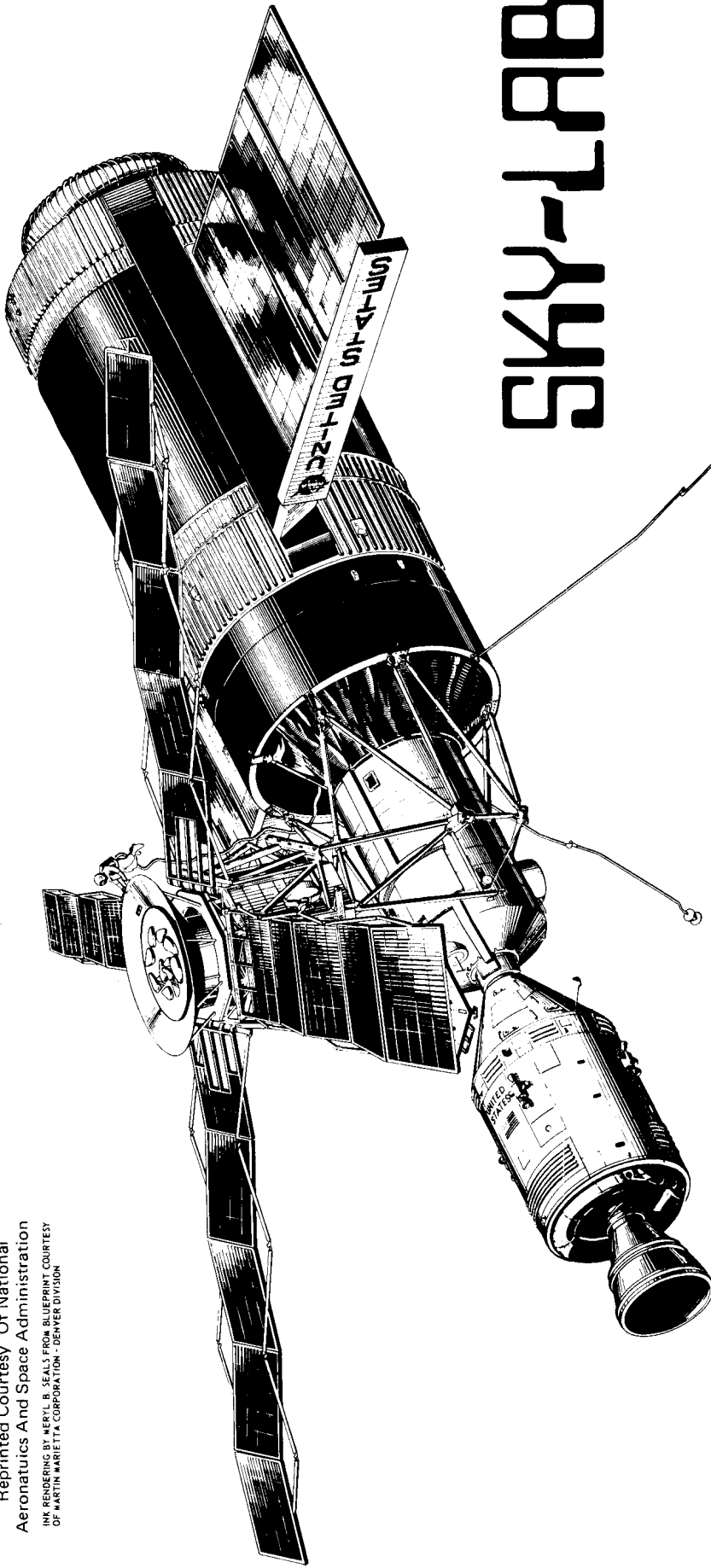

SKY-LAB

The Sky-Lab Program is expected to provide many of the answers needed in the development of large, permanent space stations. Knowledge gained in Sky-Lab experiments should more than repay the cost of the program.

How will the human body react to weightlessness in orbits of almost two months duration?

What type of work can man perform during these extended periods in space stations?

What services can best be provided by space stations to help improve life on Earth?

The Sky-Lab's unique design incorporates the huge third stage of the Saturn-V launch vehicle, providing an orbiting facility equal to a medium sized home on earth. The Saturn-1B rocket, previously used as an Apollo test vehicle, is the rendezvous ship for astronauts going to the Sky-Lab.

The long duration orbits provide time for many in-flight experiments, such as:

EARTH RESOURCES — experiments to investigate practical applications of remote sensing of the earth resources and environment, weather study, pollution detection, population and traffic pattern mapping, and other ecology phenomena.

TECHNOLOGY — the study of space effects on various scientific phenomena and industrial arts such as making lightweight steel, similar to styrofoam.

SCIENCE AND ASTRONOMY — experiments designed to study geophysics, the physics of the upper atmosphere, and galactic and intergalactic astronomy. Special emphasis on observations that cannot be made by astronomers on earth because of the earth's atmosphere.

BIOMEDICINE — experiments to study living conditions and medical treatment in zero gravity. For example, heart disease patients may some day be treated in hospital space stations, where their bodies can be relieved of the stress of Earth's gravity.

Sky-Lab is expected to put the United States firmly on the road toward development of permanent space stations. As with all great, adventurous endeavors, Sky-Lab may provide truly revolutionary benefits to mankind that can not be predicted now.



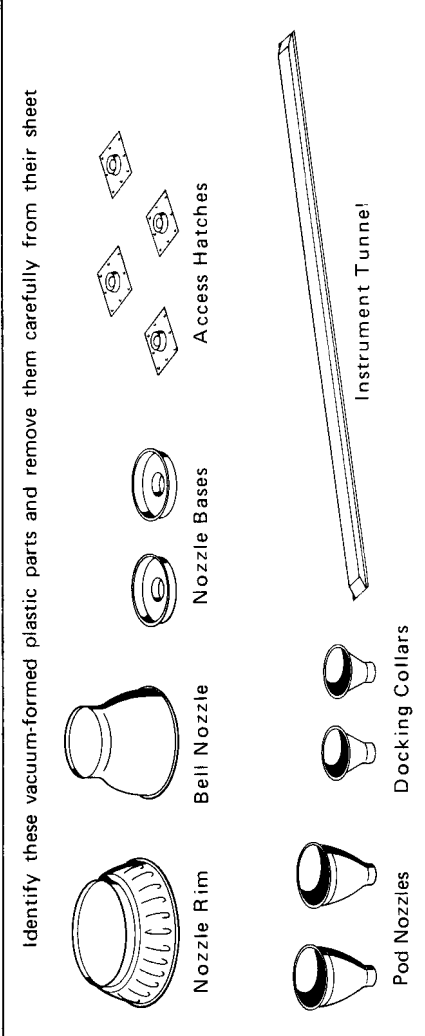
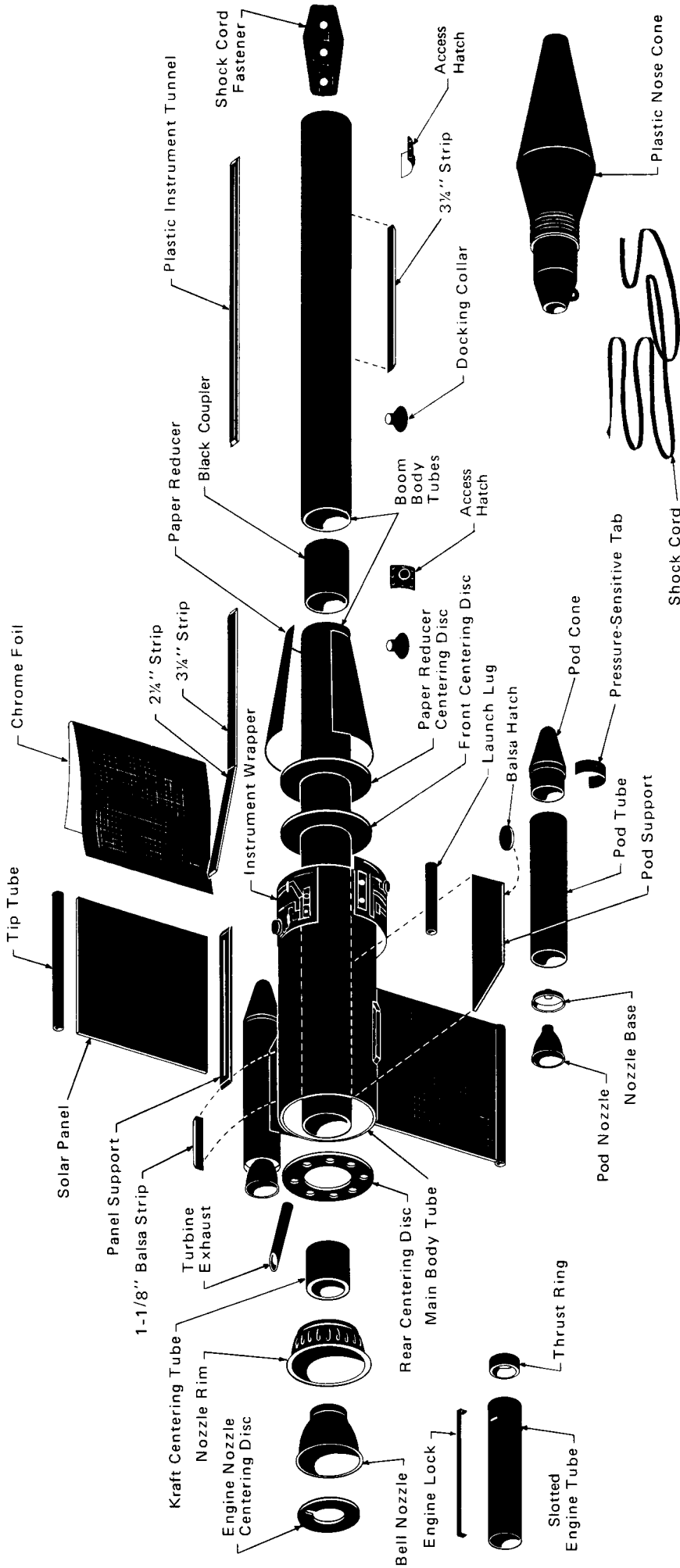

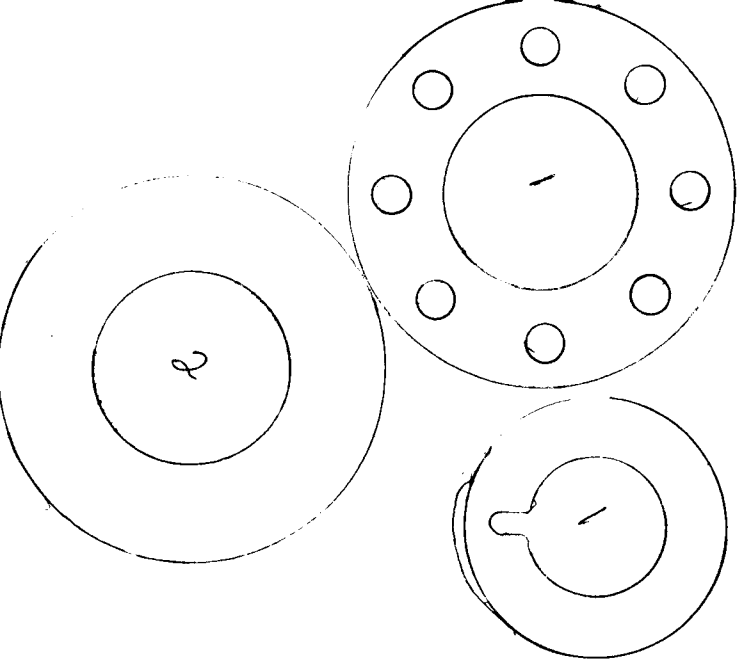

S S
L L
6 6

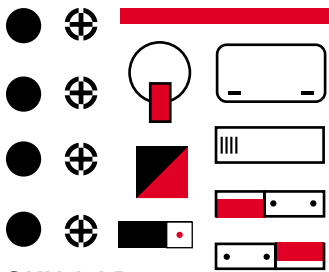

SKY-LAB



M-342

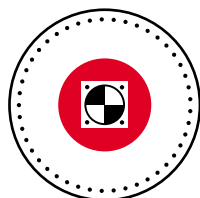
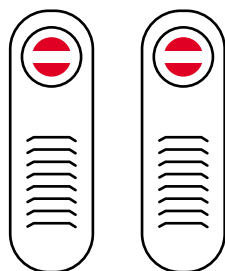
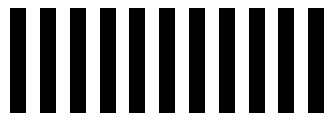

S
S
S
S
S

N
N
N
N
N

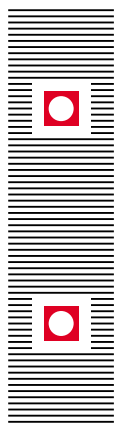
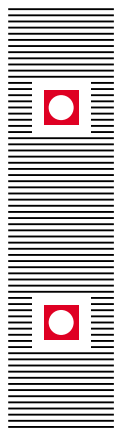

Centuri Sky Lab #KB-4 Parts Specs

A. Main Nose Cone:

Nose cone length from the top of the ST-10 to the top of the cone. (4 3/8")

The horizontal distance from the top of the ST-10 to the nose cone large diameter. (1 7/8")

The large diameter of the nose cone. (approx. 1 5/8")

The small diameter at the top of the nose cone. (1/2")

B. Pod Nose Cones:

The horizontal length of the nose cone from the top of the ST-7. (1")

The horizontal distance from the top of the ST-7 to the point on the nose cone where the straight surface ends and the radius for the top begins. (13/16"; these are near perfect rounded cones, hard to measure.)

The diameter of the nose cone at the point where the straight surface ends and the radius begins. (7/32")

C. Pod Nozzles:

Large Diameter (5/8")

Small Diameter (7/32")

Horizontal height of nozzle from installed glue joint. (3/8")

Length of recess from the end of the ST-7 to the base of the nozzle. (Nozzle base insert is recessed 1/8" into ST-7)

D. Main Nozzle: (Main Nozzle is two-piece; nozzle and separate skirt)

Large diameter (1 1/2")

Horizontal distance from the large diameter to the middle diameter. (Skirt is 3/8" tall)

Middle diameter (Base of nozzle bell is 1 3/16")

Horizontal distance from the middle diameter to the small diameter. (11/16")

Small diameter (approx. 3/4"; fits over ST-7)

E. Docking Collars:

Large diameter (5/8", including 1/32" plastic flare edge)

Small Diameter (1/4"; these are nipples that are glued into hole you make in ST-10)

Horizontal height of collar above the ST-10. (approx. 1/8")

F. Parachute:

Diameter (20")

Number of panels (or shrouds) (8 shroud lines)