

Sting Ray

MINIJET BOOST GLIDER

GLIDER ASSEMBLY INSTRUCTIONS:

Epoxy glue is recommended for all construction.

Temporarily assemble wing and flaps and tape together on the underside. Sand entire wing to an airfoil shape. Cut flaps to fit shape of wing.

Disassemble all parts and bevel both wings so they fit together when one tip is raised 1 1/2". Lay a piece of wax paper on a flat surface. Place one wing on the wax paper and hold in place with pins or weights. Apply epoxy glue at the wing junction and assemble the wing so that one tip is raised to a 1 1/2" dihedral. Allow to dry.

Sand and coat wing and flaps with sanding sealer. Sand recoat as necessary to obtain a smooth surface.

Carefully remove backing from about 2" of the front tip of the adhesive mylar. Cut off the backing so that about 2" of the mylar shows. Align entire piece of mylar so that the point is at the top front center of the wing and the sides intersect the rear outer edge of the wing. Carefully remove the rest of the backing and carefully put mylar in place. Finally, turn wing over and attach flaps flush with rear of wing as shown. Trim the mylar to shape of wing.

Notch between flaps as required so they will reach 1/8" above top of wing when they are pushed up.

Cut out 1/8" balsa fuselage using full size pattern.

Glue rudder in position where shown on side view on underside of fuselage and glue fuselage to underside of wing along center line with rear end of fuselage 1" from rear of flaps. Do not glue flaps to fuselage. Allow to dry.

Cut a 2 1/2" piece of wire and bend to shape shown. Lay the spring along fuselage so that the 1/4" bend is 1/16" from rear of flaps. Mark position of 1/8" bend and push a pin through fuselage at wing joint. Insert straight end of spring through pin hole and twist in place parallel to fuselage with the 1/4" end across the flap joint. Bend spring at hinge joint until flaps are held in the 1/8" up position after adjusting. Glue forward end of spring only.

Glue 1/16" x 1/8" strip along top of fuselage from front of wing to front of fuselage. Strip from pylon will be glued to this later.

Sand the front and bottom of the fuselage round. Leave the top flat to fit the pylon.

Build "pop" pod. (See "Pop" Pod Assembly Instructions.)

FLYING INSTRUCTIONS:

The Sting Ray is designed to be flown with Mini Jet engines 1/2A3-3M, A3-4M, and B3-5M, in Hornet, Sparrow and Swift Boost Glider NAR Events.

Glide test the Sting Ray by launching the glider from shoulder height parallel to the ground. Trim for best glide using clay as weight. Do not attempt to throw the glider like a hand launched glider. It is not designed as one.

For testing, load the "pop" pod with a 1/2A3-3M engine in accordance with manufacturer's instructions. Push flameproof wadding into body tube until it rests against engine block. Fold the streamer and insert it into body tube. Install nose cone. Nose cone should fit snugly to insure separation of pod. Attach pod to glider. Place on launch pad, follow safety instructions and ignite engine. Bird should rise vertically. After ejection, pod should separate. After powered flight it may be necessary to retrim glider for best glide.

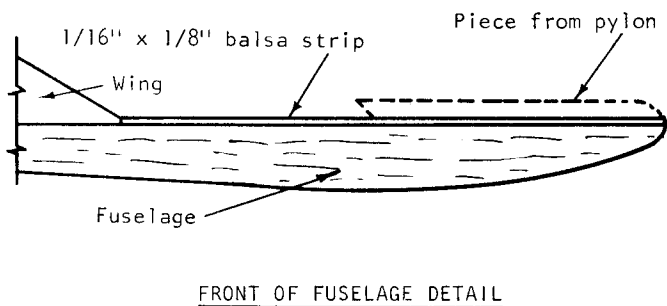
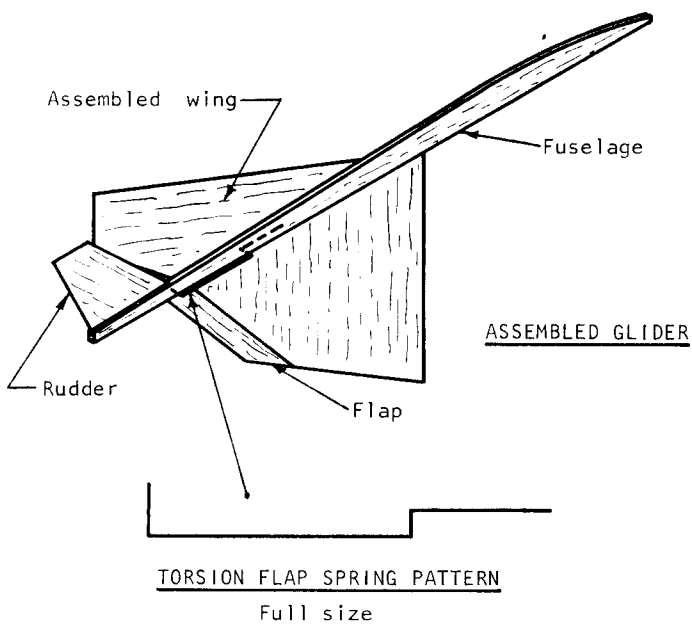
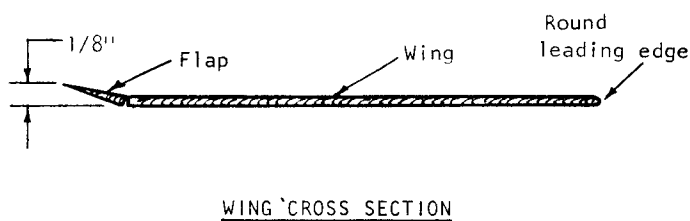
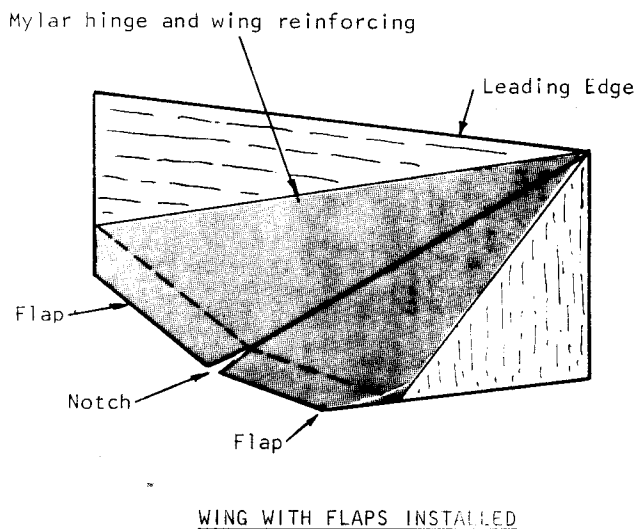
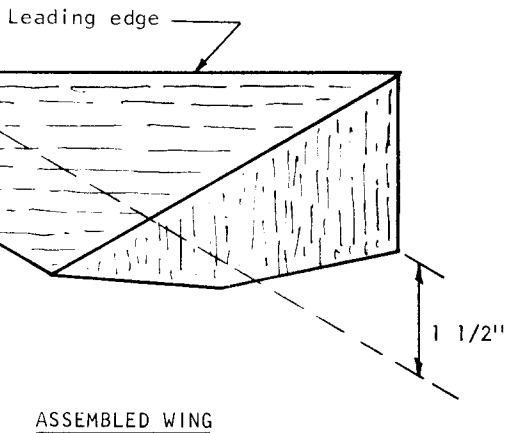

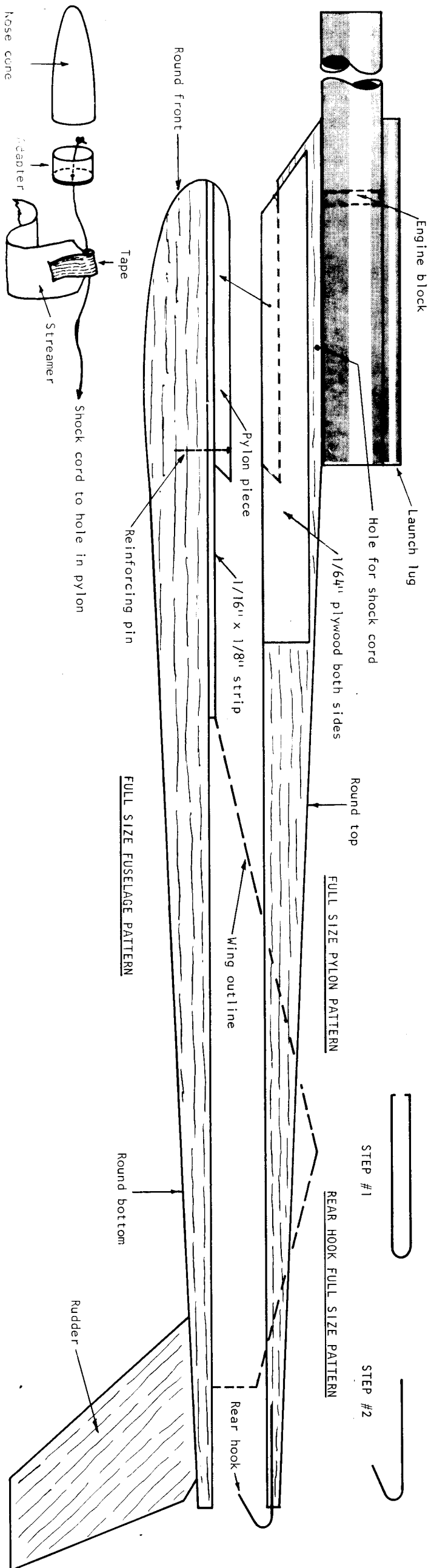

"POP" POD ASSEMBLY INSTRUCTIONS:

Start assembly of nose cone by inserting shock cord through hole in bottom of nose cone adapter. Tie knot large enough to keep cord in place.

Put a thin coat of plastic (styrene) cement around inside of nose cone. Rub cement with the end of your finger to smooth it out and remove excess. Use cement sparingly as it will melt nose cone.

Insert adapter into nose cone then slip nose cone into body tube to insure alignment. With a twisting motion, carefully remove nose cone from body tube and allow to dry.

Cut pylon from 1/8" balsa using full size pattern. Cut out strip at front and glue to front of fuselage. To properly position this piece, place pylon flush with rear of fuselage and mark position of notch. When dry, push pin through top of strip as shown. Make sure pin head is below top of strip. The pin reinforces the strip for powered flight.

Glue body tube to top of pylon so that the rear of tube is 3" from front of pylon.

Cut 1/64" plywood to shape shown on full size pylon pattern and glue to both sides of pylon. Do not get glue in notch or it will not fit properly on fuselage.

Glue launch lug on top and flush with rear of body tube. Align launch lug so that it is parallel to body tube.

Round front and top of pylon for better performance. Coat top of pylon with epoxy glue to prevent burning.

Attach the shock cord to the pylon by pushing a hole through the pylon 2" from the front edge just below the body tube. Insert shock cord through hole at least one inch, fold to rear and glue along body tube and pylon joint.

Attach streamer to shock cord with tape near nose cone.

Install engine block by smearing white glue around inside of body tube with a cotton swab or brush 2" from rear. Insert engine block in rear of body tube and push it forward with an engine casing until 1/4" protrudes. Remove engine casing immediately as soon engine block is positioned.

Cut a piece of wire 3" long and bend to shape shown in Step #1 and Step #2 and glue in place at rear of pylon. This wire holds pod in place and keeps flaps down during powered flight. Adjust wire by bending as required. Notch rudder at fuselage joint to receive wire.

FINISHING AND CHECKING:

Round front and bottom of fuselage.

Coat all wood and paper surfaces except wing with sanding sealer or clear dope. Sand then recoat as necessary to obtain a smooth surface. Do not paint nose cone.

Fit "pop" pod on glider so that the strip on front of fuselage fits into space where it was removed. At the same time hook wire over rear of fuselage. By moving pylon forward the "pop" pod and the glider should interlock and the flaps should be fully depressed. If the pod fits properly you should be able to pop the pod off the glider by hitting the nose cone lightly with the palm of your hand. Adjust as necessary until the pod comes off easily with the flaps fully depressed.

See Flying Instructions next.

[Pylon and Fuselage]
1/8" x 1/2" x 12"
Balsa
(Make 2)

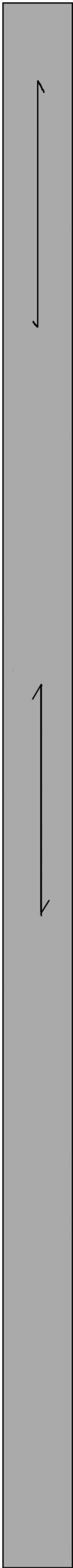

[Pylon Side Piece]
1/64" x 1/2" x 4"
Plywood
(Make 2)

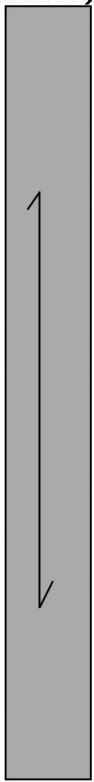

[Vertical Stabilizer]
1/16" C-Grain Contest Balsa
(Make 1)

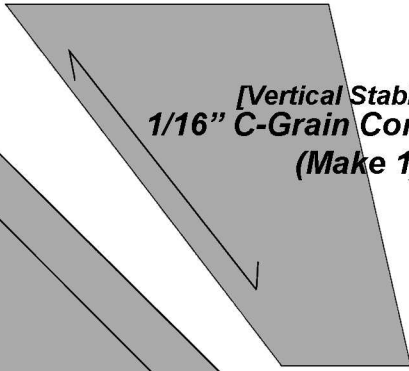

[Main Wing]
1/16" Thick C-Grain Contest
Balsa
(Make 2)

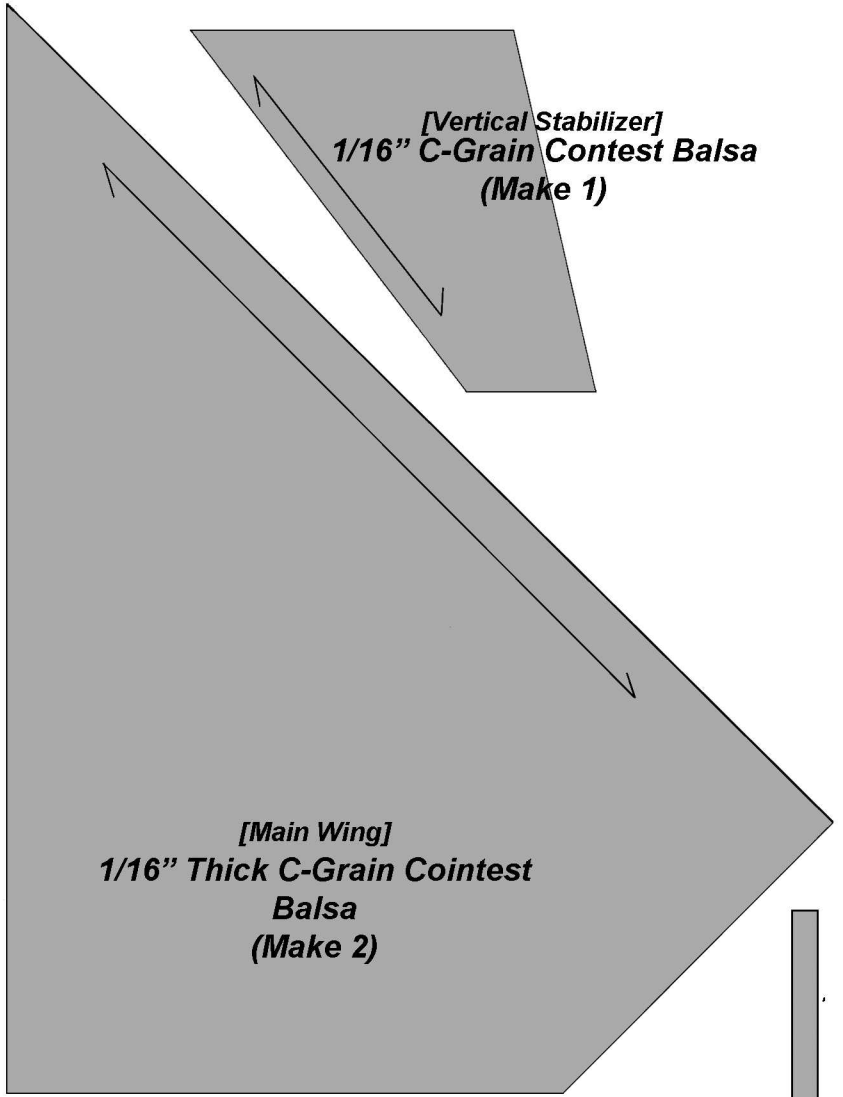

[Elevon]
1/116" Thick C-Grain Contest Balsa
(Make 2)



[Support for Pylon X-Piece]
1/8" x 1/16" x 5" Hard Balsa
(Make 1)



Wood Parts Templates for CMR BG2 String Ray

Note: templates were ray-traced from scanned images of parts. They are not hand tracings or redrawn pictures

Print This Page On 8.5 x 14 Inch (Legal) Paper

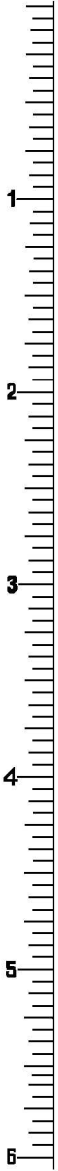

CMR BG2 Sting Ray Parts List

Qty	Description of part	Illustration #
2	Main wing (1/16" balsa)	1
2	Elevon (1/16" balsa)	2
2	Fuselage and pylon (1/8" x 1/2" balsa)	3
2	Pylon side (1/64" plywood)	4
1	Pylon support piece (1/16" x 1/8" balsa)	5
1	Vertical stabilizer (1/16" Balsa)	6
1	Body Tube (13mm x 6")	7
1	Motor bock for 13mm motor	8
1	Vacuformed nose cone and base for 13mm tube	9
1	Crepe streamer (1 1/2" x 12")	10
1	Piano wire	11
1	Shock line (12")	12
1	Silver mylar (trim Monocote)	13
1	Instruction sheet	14

