

D-REGION TOMAHAWK

EXACT FLYING SCALE MODEL OF NASA FLIGHT NO. 12.08 GT

D-REGION TOMAHAWK HISTORY

There was only one D-Region Tomahawk flown. The objective of the test flight was to determine vehicle performance and establish the payload environment during flight. To accomplish these objectives, the payload carried three accelerometers, two vibration transducers, one stable platform to measure vehicle attitude, ten temperature transducers to measure temperature environment of the payload, and one pressure transducer to measure chamber pressure on the TE-M-416 rocket motor. Vehicle No. 12.08 GT was launched from Wallops Island, Va. at 1900 Z 5 Feb. 1968 and reached a peak altitude of 118.5 KM (73.7 St. Mi.). The vehicle performed as predicted with all instrumentation operating to impact. The rocket was recommended for acceptance in the NASA stable.

ASSEMBLY INSTRUCTIONS

Build payload section (See Payload Section Construction).

Wrap shock cord around 1/2" wide anchor ring twice and tie with a 1" piece of narrow paper tape. Glue anchor securely into body tube 1 1/2" from front end.

Glue 3/16" fibre thrust ring flush with front edge of 2 3/8" engine mount. When dry, insert FSI engine into mount, smear inside of body tube with glue and push engine in mount into body tube until engine is flush with rear. Remove engine and allow to dry. If no engine is available, make distance from thrust ring to rear of body tube 2 3/4".

Build 8" parachute for nose cone and 12" parachute for rocket body. (See Parachute Instructions.)

Build pop launch lug. (See Pop Launch Lug Construction.)

Build fins and shroud. (See special details on complete fin and shroud assembly.)

Sand main body tube with fine sandpaper until smooth. Push assembled fins and shroud onto rear of body tube. Adjust shroud until .21" of body tubing is showing at rear. Mark front and rear of body tube at junction of shroud. Push shroud assembly forward and smear area between marks lightly with epoxy glue. Slide shroud to rear until rear of shroud is over mark. Remove any excess glue and allow to dry.

Mask off painted fins as shown on drawing making sure that paint cannot get on fins, especially if spraying. Coat shroud, fin reinforcing, prototype launch lug, and body tube with sanding sealer. When dry sand smooth. Spray or paint the entire area flat white. When dry remove masking material and paint the rear of the body tube extending beyond the shroud, steel gray.

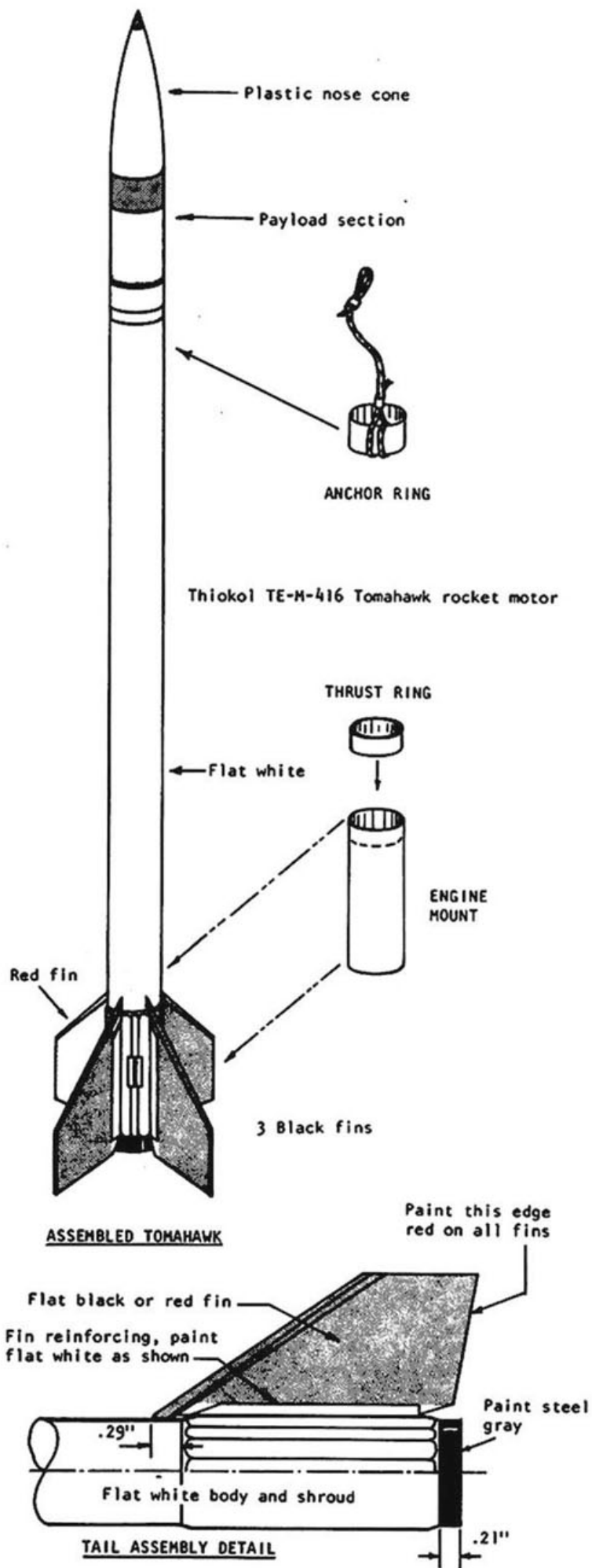

PAYLOAD SECTION CONSTRUCTION

The payload section can be constructed in one of two ways depending upon the amount of detail desired. The instructions cover only the super detailed model. If the simpler model is preferred, assemble the payload without cutting the modules and paint on the modules and screw heads afterward.

Temporarily assemble the payload section by inserting the 3 1/4" RB90 body tube into the 2.34" RB92 body tube so that 1/4" projects at one end and approximately 3/4" from the other end. Mark position with pencil.

Put plastic (styrene) cement around inside edge of plastic nose cone. Rub cement with end of your finger to smooth it out and remove excess. Use cement sparingly as it will melt nose cone. Push nose cone over the 1/4" of body tube that protrudes until tight with the outside tube, then push the outside tube away from the nose cone without disturbing it. Allow to dry.

When dry, push outside tube back against the nose cone and sand assembly lightly with fine sandpaper until smooth.

Cut out pattern for payload modules and mark each module using the pattern as a guide. Also use pattern for marking top edge of body tube to be painted flat

Remove the outside tube, coat with sanding sealer and lightly sand it smooth. Slip it over a 7/8" dowel and cut it into the modules using a lathe or CMR Body Tube Cutter.

Wrap 4" shock cord around a 1/2" split anchor ring. Tie with a 1" piece of narrow paper tape while stretching rubber. Form a loop in the other end of the shock cord and tie with a 1" piece of paper tape while stretching rubber. Glue anchor ring securely with white glue into inside of payload section 1/2" from edge.

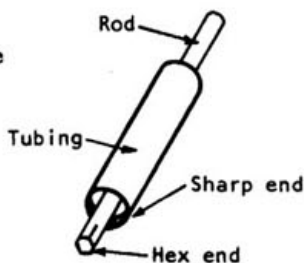
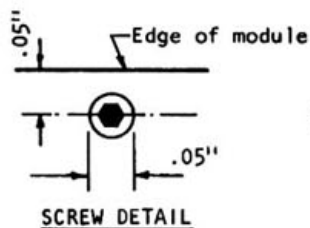
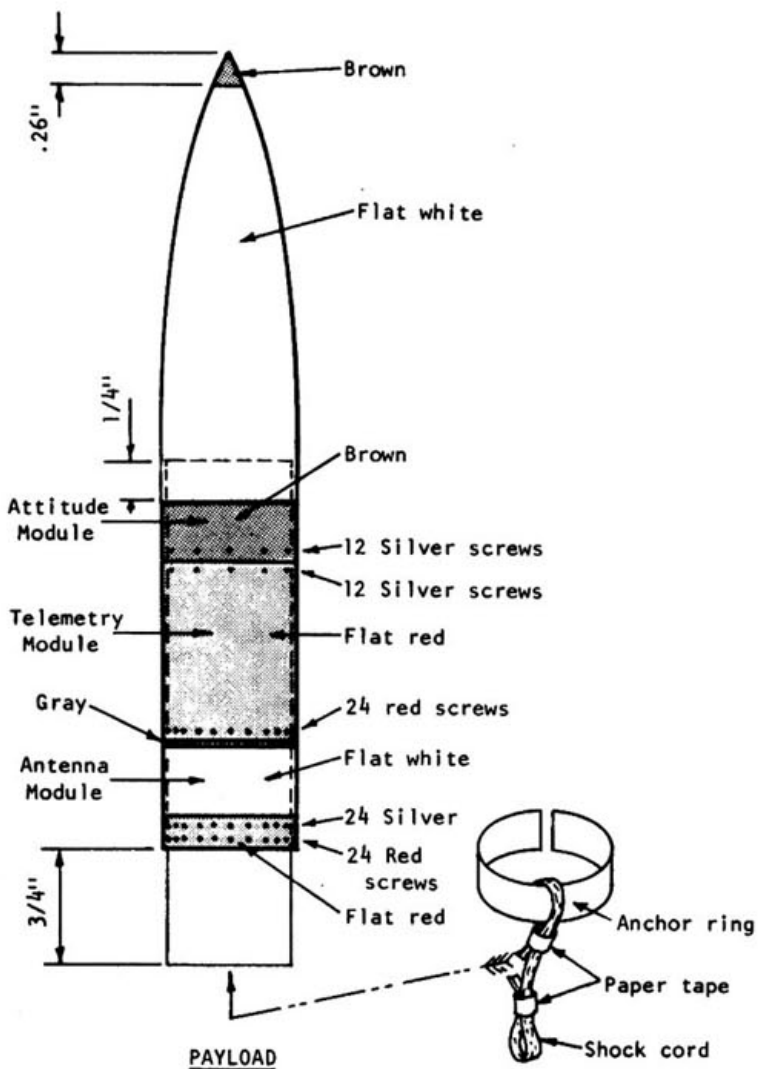

Make a screw detail tool from the tubing and rod furnished. Tubing is sharpened at one end and rod must be filed to the shape of an Allen screw center hexagonal as shown. This tool will also be used on the shroud later.

Cut out the screw pattern and mark off the screw locations on the proper modules as shown on drawing.

Elevate ends of dowel to keep from crushing tubing and clamp dowel to work table.

Place sharpened end of metal tubing over screw location and tap lightly with a hammer. While still holding the tubing in place, insert rod through center and tap end of rod lightly. This should indent a small circle in the body tube with a hexagonal hole in the center. Practice on extra body tubing until you develop the right technique. (It is not easy but when done correctly makes a super detailed model.)

Paint each module separately in colors as shown on payload drawing. Paint screw heads silver or leave red as indicated. Paint tip of nose cone. Allow to dry.

Glue each module in their proper position making sure that the screw holes are aligned correctly.

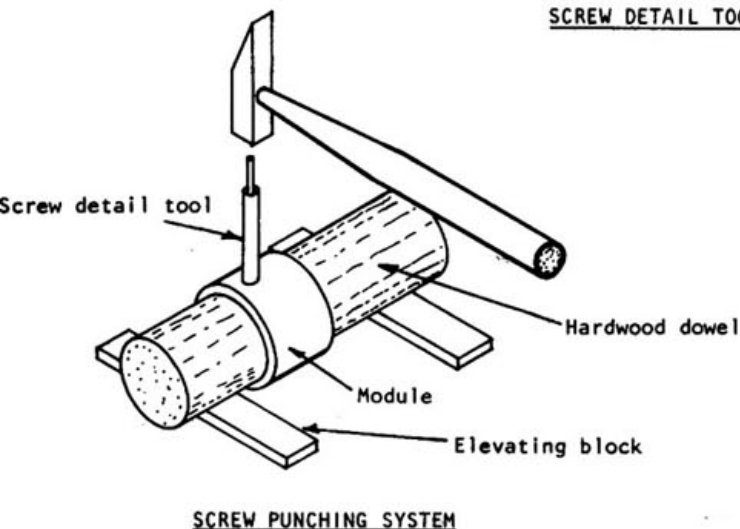

Edge of paper fin

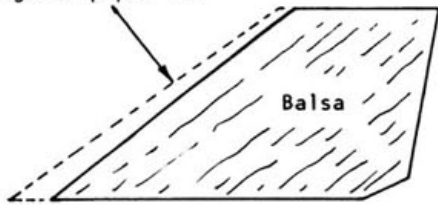

BALSA FIN

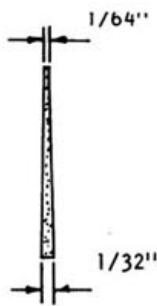

TAIL FIN CONSTRUCTION

In order to get accurate detailing and a smooth finish each fin is constructed in 3 pieces - a piece of balsa sandwiched between two pieces of paper.

Cut out pattern for balsa fin. Place on balsa and draw around pattern with a sharp pencil. Cut out balsa with a sharp razor blade against a metal straight edge for the greatest accuracy. The balsa fin is shorter at the leading edge than the paper fin.

The real fin is tapered away from the root edge. If accuracy is desired, use a sanding block and sand balsa fin to taper as shown on drawing.

Cut out right and left paper fins along the outside edges. The two remaining lines along the leading edge represent the cuff on the real tail fins.

Put a metal straight edge along the leading edge lines and carefully cut the paper about half way through. Do not cut all the way through the paper.

Carefully fold the first line from the leading edge down across a sharp edge to about a 30° angle. Do this to all fins. When completed there should be four right fin halves and four left fin halves. The second line gets cut but not folded as it only represents the junction of the cuff and fin material.

Smooth coat balsa fin and inside of paper fin with epoxy glue and put together so that all edges match and paper fins meet at a point at the leading edge. Set aside and allow to dry thoroughly. Do not use white glue since it has the tendency to shrink the paper.

Coat all fins with sanding sealer and sand smooth with fine sandpaper.

Spray or paint 3 fins flat black and one fin flat bright red. Paint the rear edge of each black fin flat bright red.

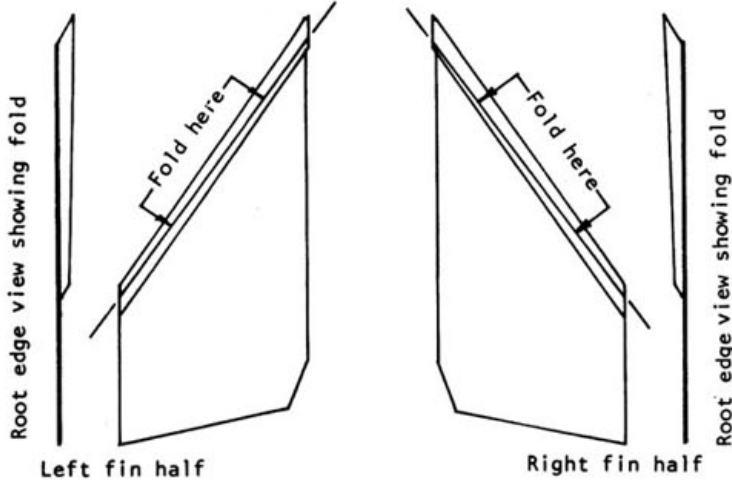

PAPER FIN



SHROUD CONSTRUCTION

Cut out paper shroud around outside edges. Place a metal straight edge along each solid line and with a sharp razor blade carefully cut halfway through the paper along each of the solid lines. Carefully fold the shroud at each of the cut lines until it forms a cylinder.

Place the 2.28" split body tube over the main body tube flush with rear end. Wrap shroud around the split body tube and check fit. Edges of shroud should meet. Trim if necessary.

Note that the split body tube does not meet. This is done purposely to insure a tight fit around rocket body under all conditions. Fill opening with a paper strip cut from pattern sheet and epoxy glue after removing from body tube.

Carefully smear epoxy glue on inside of shroud and wrap around split body tube. Be careful not to glue split body tube to main body tube. Wrap shroud with rubber bands and allow to dry.

When dry remove shroud from main body tube and place over a hard wood dowel and sand both edges to a 15° angle as shown on drawings. For best results, this procedure should be done on a lathe.

Coat with sanding sealer and sand smooth.

Using the screw detail tool, punch screw locations where shown on drawing.

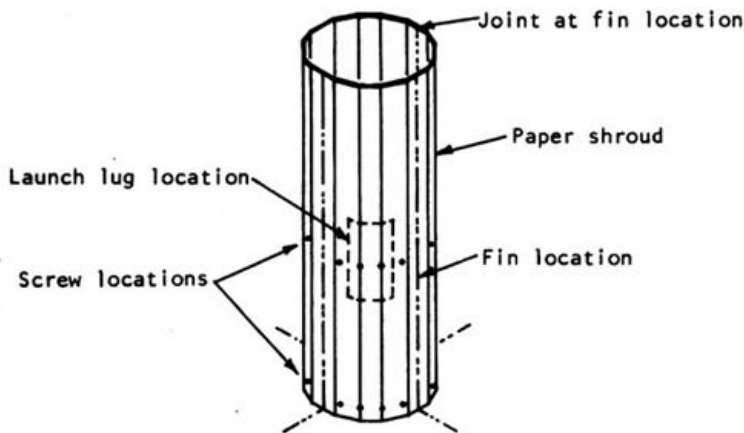

FOLDED SHROUD

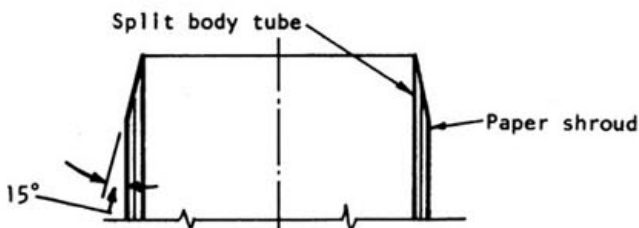

ENLARGED SHROUD EDGE DETAIL

Same both ends

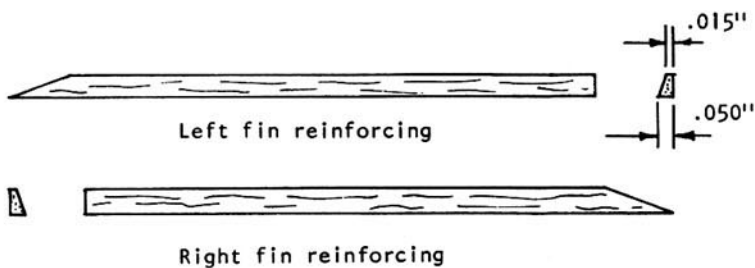

FIN REINFORCING

Sand balsa to shape shown. Cut one right and one left fin reinforcing for each fin, using pattern on special pattern sheet. These will be glued to each side of fins later.

PROTOTYPE LAUNCH LUG

From patterns cut prototype launch lug from 1/32" balsa and assemble as shown. Punch 2 screws with screw detail tool. This will be glued to shroud later.

The bottom of the launch lug must be slightly curved to fit the shroud properly. This can be done by slightly wetting the bottom of the launch lug and carefully bending it until it fits the curve of the shroud. Allow to dry completely before gluing to the shroud.

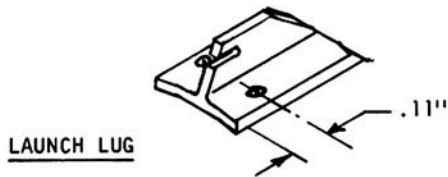

SHROUD AND FIN ASSEMBLY

Glue the four fins using epoxy glue 90° apart on lines drawn on shroud. Front edge of fin extends .29" beyond shroud. Using the launch lug position as a guide glue the black fins on first as shown on drawing. Then the red fin. Allow to dry.

Glue right and left fin reinforcing on each side of all fins so that the pointed edge is forward and the square edge is even with rear of fin at root edge. See drawing.

Glue prototype launch lug in position on shroud with hook opening toward rear. Allow shroud assembly to dry.

The shroud, fin reinforcing, shroud screws, and launch lug are painted flat white at the same time as the rocket body. It should be noted that part of the fins next to the front and rear of the fin reinforcing are painted flat white as shown on the tail assembly detail.

This assembly is constructed exactly the same as the prototype.

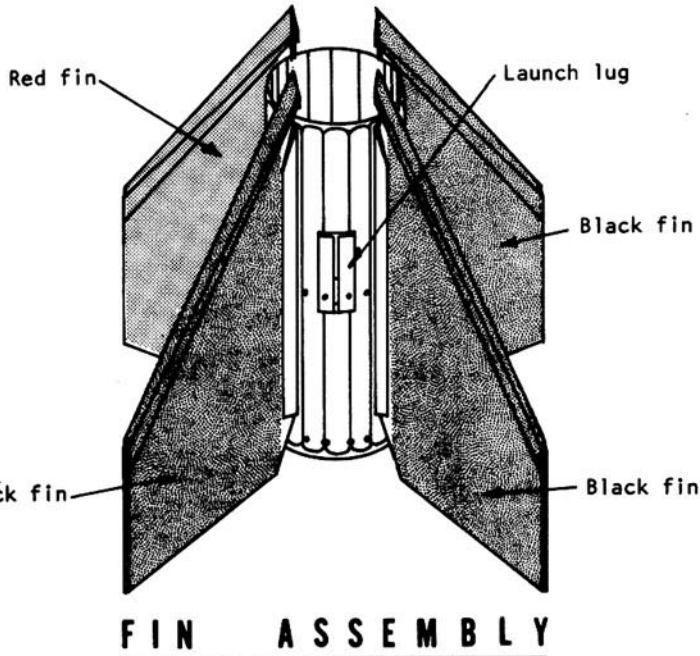

FLYING INSTRUCTIONS

Assemble the rocket complete with FSI B3-4 engine and parachutes. Balance on a straight edge. Add weight (clay is ideal) to payload section until model balances 13 1/2" from tip of nose cone.

The rocket should be flown with a FSI B3-4, C4-4, or D4-4 (21 mm diameter) engines for best results. The bird can be converted for use with standard engines (18 mm diameter) by using CMR engine mount kit EM7490.

To prepare for flight, wrap masking tape around engine and insert into body tube so it fits tight. Pack flameproof wadding into front of body tube until it rests against front of engine. Attach 12" parachute to shock cord in rocket body, fold carefully and insert it into body. Attach 8" parachute to shock cord on payload, fold and put into rocket body. Insert payload.

Attach "Pop" launch lug. Install igniter in engine in accordance with manufacturers' instructions. Put rocket on rod, then wrap two or three turns of masking tape around top of rod to act as a stop for the launch lug.

Following safety instructions of engine manufacturer, attach igniter clips, start countdown and fire. The bird should rise off the pad smoothly and leave the launch lug on the rod.

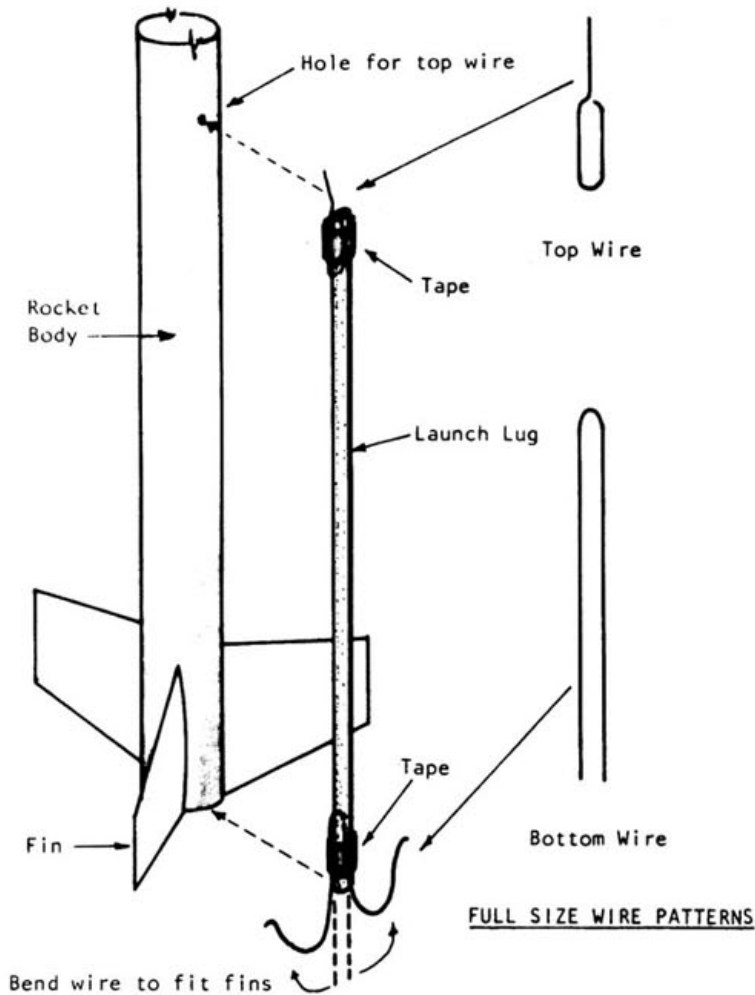

POP LAUNCH LUG INSTRUCTIONS:

Cut one piece of wire 1 1/2" long and bend to shape of top wire. Bend remaining piece of wire in half to hairpin shape of bottom wire.

Cut paper tape into two equal pieces. Peel off backing and wrap around top and bottom wires and launch lug as shown. Make sure wires are aligned on same side of launch lug.

Bend bottom wire to hook around two fins so that launch lug is centered between fins. Hook launch lug over fins and mark body tube 1/4" from tip of top wire. Drill or punch hole at this point and bend front wire downward to fit easily. Adjust so that launch lug is snug but will pop off easily when pushed on top.

The pop launch lug is always attached after the rocket is prepared for launching complete with engine, recovery device and nose cone installed. To use pop launch lug, slide lug over rod, slip a 1" piece of plastic tubing, or wrap top of rod with 2 or 3 turns of masking tape. Rod must be tight on launch pad. After rocket leaves pad the pop lug will remain on the rod. The rocket can be reattached to the lug without removing the lug from the rod.

PARACHUTE INSTRUCTIONS:

Parachute is precut to a circular shape. Fold in half, then fold in thirds to obtain the location of the shroud lines. Crease parachute at folds or mark with marking pencil. Cut off tip of parachute when folded to provide a vent hole to aid in parachute folding and opening after ejection. When reopened there should be 6 equally spaced places for shroud lines.

Cut 6 shroud lines, equal in length to the diameter of the parachute.

Cut 6 pieces of wide tape about 5/8" long. Peel off paper backing and attach by pressing tape over a loop of shroud line.

Gather free ends of shroud line together, insert through snap swivel and tie into a knot. Apply a drop of glue to knot so it will not loosen. Attach snap swivel to hook in nose cone or payload coupler.

There are many ways of folding a parachute for insertion into a body tube. Experience will dictate the best method for each individual. One way is to first dust the parachute with talcum powder to keep it from sticking to itself. Then form the parachute by holding the snap swivel with one hand and tip of canopy with the other and straighten the chute. Fold the canopy once or twice to fit the space in the body tube and insert it. Pack the shroud lines and shock cord in over the parachute and push the nose cone or payload section into place.

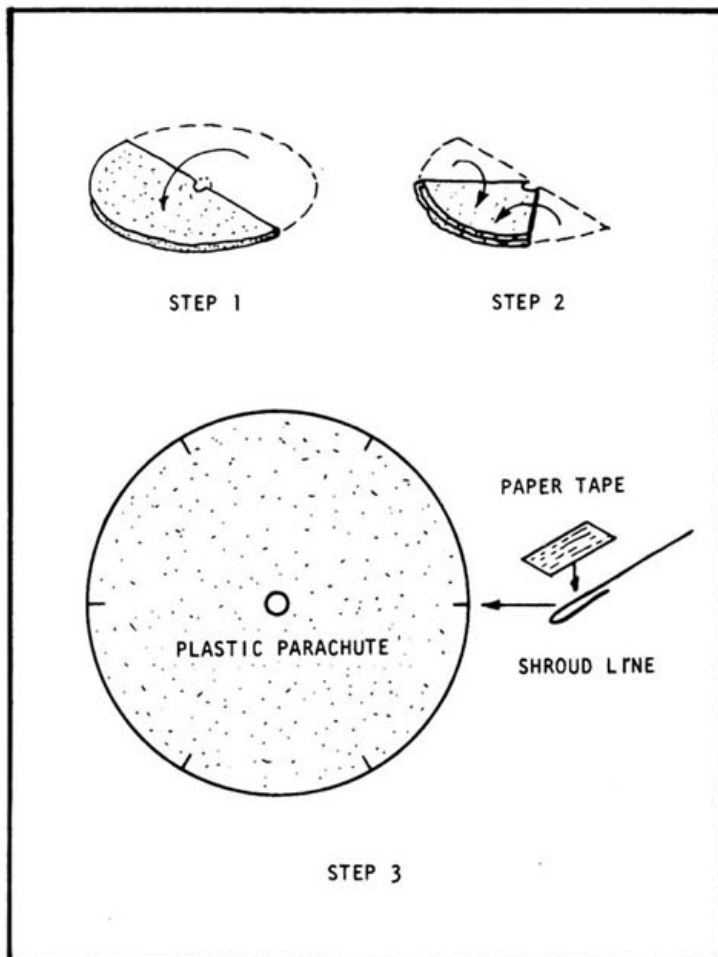

Balsa fin pattern

make 4 from 1/32" sheet

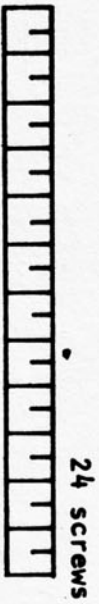
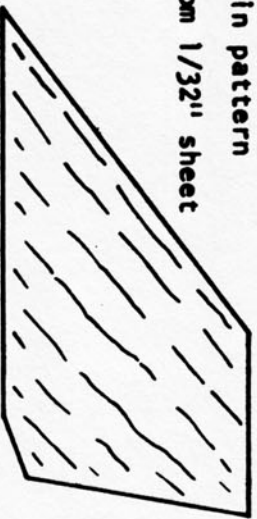

Screw pattern 12 screws



EDGE OF BODY TUBE

Paint top of body tube flat red to this mark

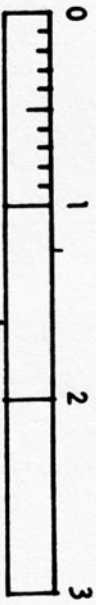
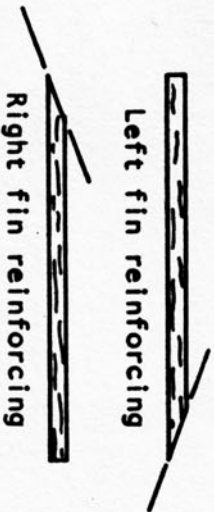

Fin locations

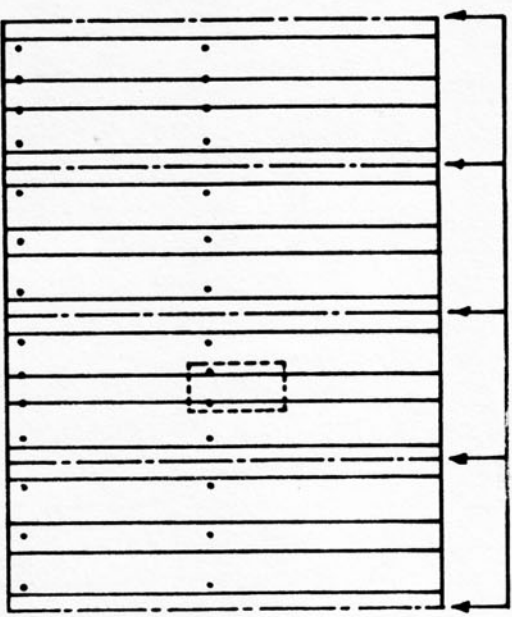

Note 4-3-4-3 screw pattern

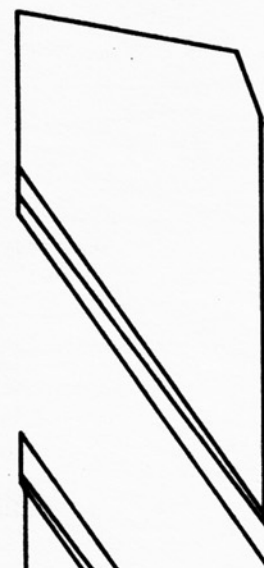
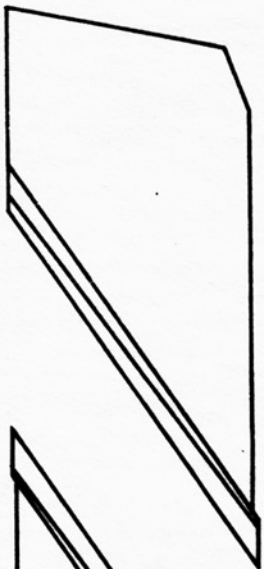

RIGHT FIN HALVES

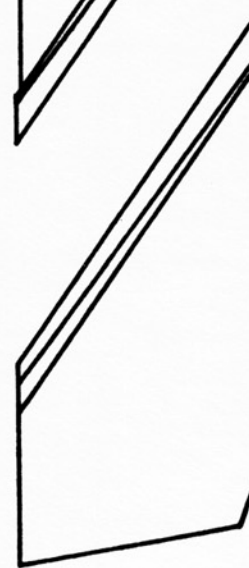
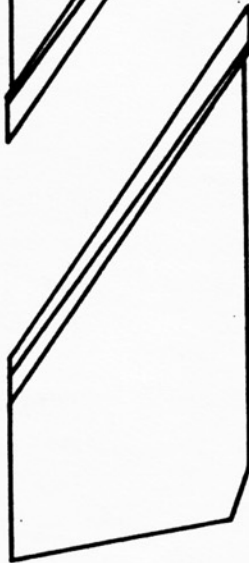

LEFT FIN HALVES

CMR D-region Tomahawk (Kit #) Parts List and Notes:

Nose Cone NC920*

Main Body Tube 14.5" RB-92

Payload Tube 2.34" RB-92

Inner Payload/Coupler Tube 3.25" RB-90

Engine Mount Tube 2.38" RB-90**

Shroud Tube 2.3" RB-9?***

Balsa Fin Stock 1/32" x 3" x 6"

Balsa Reinforcing Struts (4) 1/16" x 1/8" x ~5"

Shock Cord Anchors (2) .5" RB-90

Adhesive Backed Mylar (2) .8" x 3.94"

Engine Block EB-90

Snap Swivels 2

Parachute Kits (2) (1) 12" Mylar (1) 8" Mylar

Shock Cords (1) 6" white rubber (1) 10" brown rubber

Screw Detail Tool****

Notes: The CMR RB90 tubes had a ID of .864 and a OD of .890, and the RB92 ID was .894 and OD was .920.

*The NC920 that came with my kit is about 2.95" long. The catalogue lists the length as 2.85".

**As per the instructions, the CMR D-Region was supplied with a mount to accommodate FSI 21mm motors.

***This tube is similar to a BT50. It has a thinner wall than the RB92, but about the same OD. The instructions indicate that this tube comes pre-slit for the shroud assembly, but mine is not.

****The screw detail tool is made up of a 1" piece of very small diameter (1/32nd "?) rod, and a 1 .7" piece of brass tube that is supposed to slip fit over the rod (mine is a very snug fit).

SEL 2.17.04