





EagleWorks Pulsar II - parts

Nose cone	- BNC-5W
Body tube	- BT-5, 5"
Transition	- TA-520, 0.75"
Body tube	- BT-20, 5.25"
Basswood Sheet	- 3/32"
Transition	- TA-2050, 2.5"
Body tube	- BT-50, 8"
Launch lug	- LL - 3/16"
Motor tube	- BT-20, 3"
Centering rings (2)	- CR2050
Parachute	- PK-12 – 12"

The Pulsar II began as a design from my High School years. It was an Honorable Mention in Estes "Design of the Month" contest for June 1992. I have included to the original Pulsar design in this plan pak.

Since then I have updated the design and called it Pulsar II. The bottom fins are cut out of basswood and made up of three separate pieces. Then two side pieces are added along the root edge as well as the tip strakes. Sand the side pieces to blend in with the core fin. See the photo for a better understanding.

The Pulsar II is a great flier and performs well on A8-3 and B6-4 motors.

Buzz Nau
3/28/11

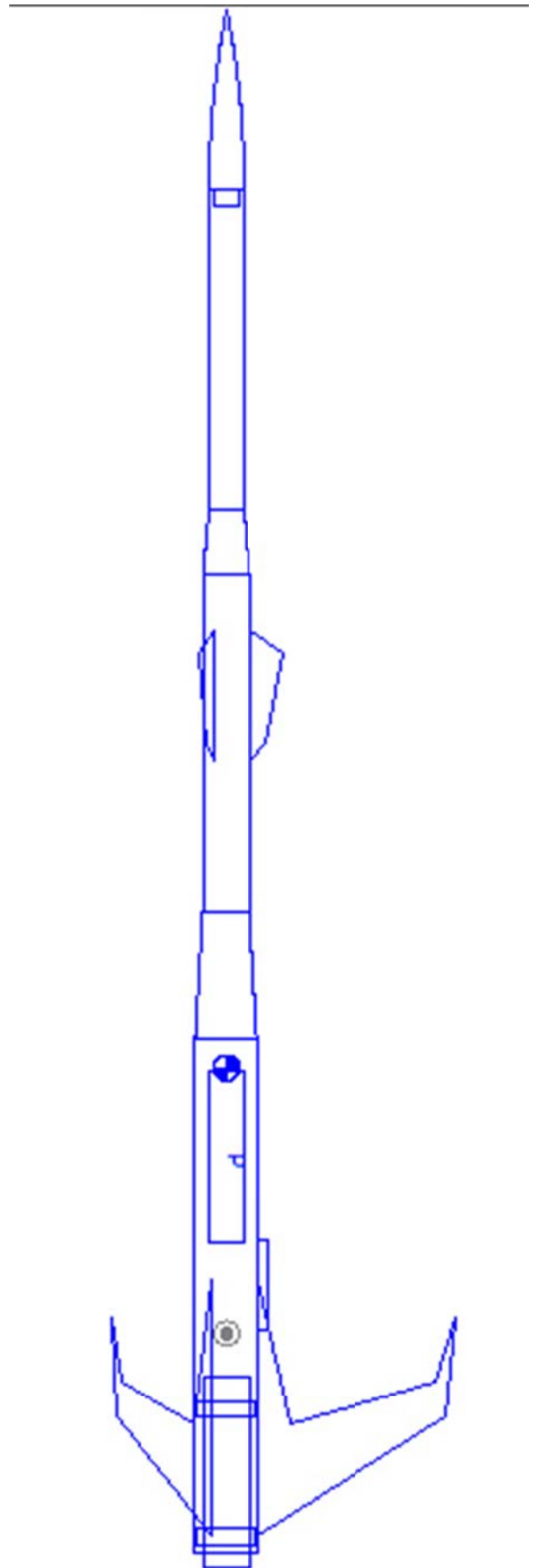

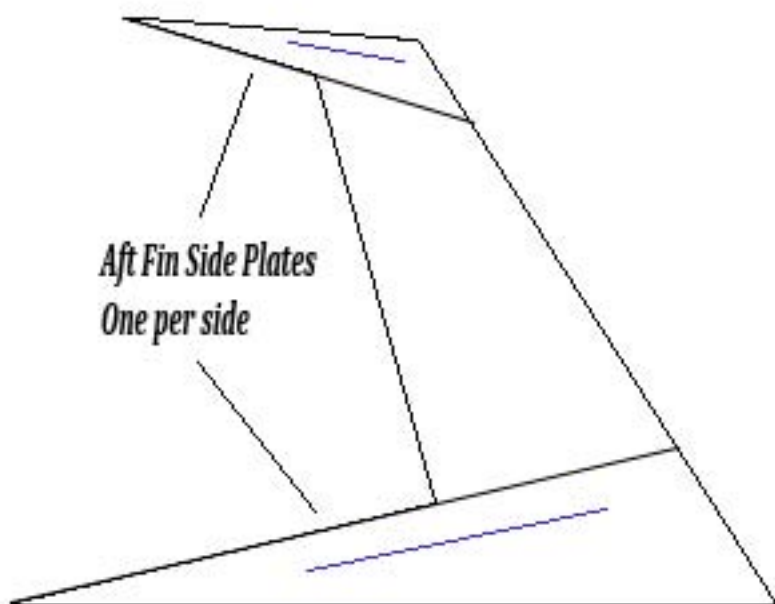





UNITED STATES

PULSAR (Original Design)

By Buzz Nau
PARTS LIST

- A) PNC-5AX
- B) BT-5, 2 1/2"
- C) TA-520 Balsa Reducer
- D) BT-20, 5 1/4"
- E) TA-2050 Balsa Reducer
- F) BT-50, 6"
- G) Fins, Make 3 from 3/32" Basswood
- H) EH-2050 Engine Mount
- J) Kevlar
- K) Round Braided Elastic
- L) Medium Snap Swivel
- M) PK-12 Chute
- N) 1/8"X1 1/2" Launch Lug
- O) Small Screw Eye

