



ESTES INDUSTRIES
1295 H STREET
PENROSE, CO 81240 USA

Ninja™

KIT #0882

BETA™ SERIES

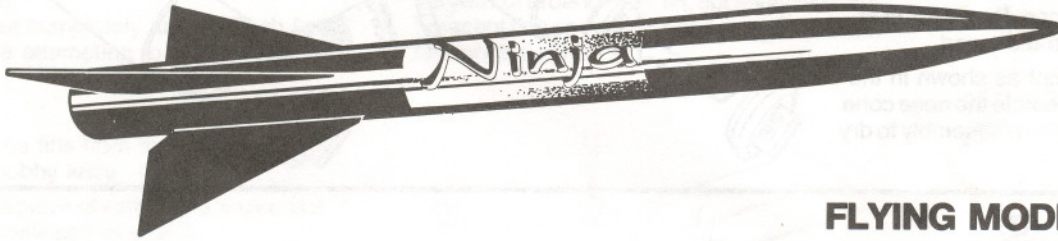

FLYING MODEL ROCKET KIT

HOW TO USE THESE INSTRUCTIONS: READ ALL INSTRUCTIONS BEFORE STARTING WORK ON THIS MODEL

- A. This rocket, incorporating basic model rocketry construction techniques, will help you in the development of your rocketry modeling skills.
- B. **Read each step first** and visualize the procedure thoroughly in your mind before starting construction.
- C. Lay parts out on the table in front of you. (Check inside tubes for any small parts.)
- D. Use exploded view to match all parts contained in kit.
- E. Collect all construction supplies that are not included in the kit.
- F. Fin marking guides, shock cord mounts and other patterns are printed in the instructions and will be found in the pages following.
- G. Test fit parts before applying any glue.
- H. Sand parts as necessary for proper fit.
- I. The construction supplies required for each step are listed at the beginning of each step.
- J. Check off each step as you complete it.

EXPLODED VIEW

ENGINE MOUNT ASSEMBLY

AIRFRAME ASSEMBLY

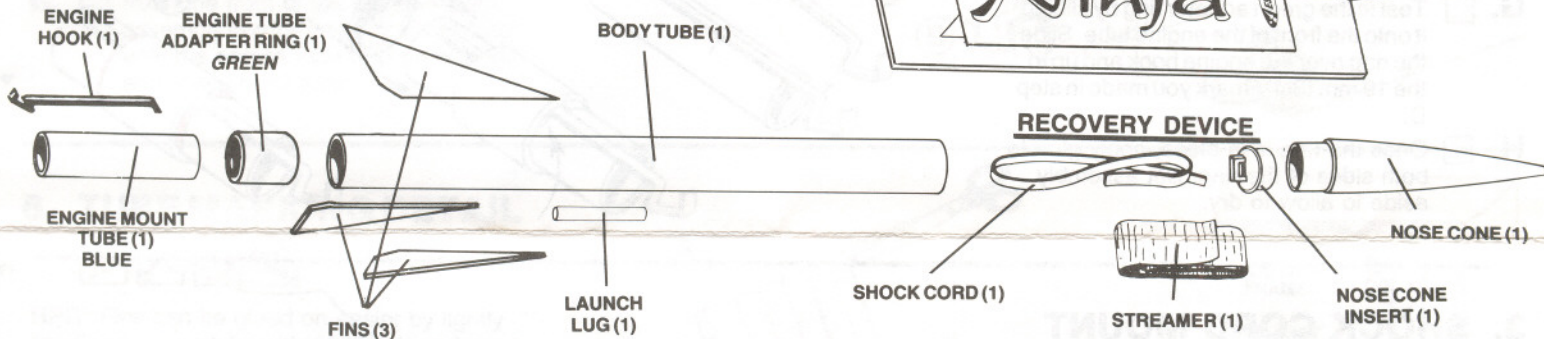

OTHER PATTERNS AND MATERIALS INCLUDED IN KIT
SHOCK CORD MOUNT (1) LOCATED ON PAGE 6
TUBE MARKING GUIDE (1) LOCATED ON PAGE 6

EXTREMELY IMPORTANT: THE EXPLODED VIEW IS FOR REFERENCE ONLY! DO NOT USE THIS DRAWING ALONE TO ASSEMBLE THIS MODEL.

The exploded view is only intended to assist you in locating the parts included in this kit. Refer back to this exploded view as you build your model step by step. This method will help you to put the parts into perspective as you progress through the construction

CONSTRUCTION SUPPLIES

In addition to the parts included in your kit, you will need these construction supplies. Each step shows which supplies will be required.



SCISSORS



PENCIL



MODELING
KNIFE



SANDPAPER



WOOD
GLUE
(white or yellow)



PLASTIC CEMENT



TAPE



PAINT

GLUE IS APPLIED TO SURFACES SHOWN IN RED.

1. NOSE CONE ASSEMBLY



NOTE: This is the only step in the construction of your model rocket that requires plastic cement.

- A. Test-fit the nose cone. Do not glue at this time. Remove the insert.
- B. Apply plastic cement as shown in the illustration and assemble the nose cone and insert pieces. Allow assembly to dry.

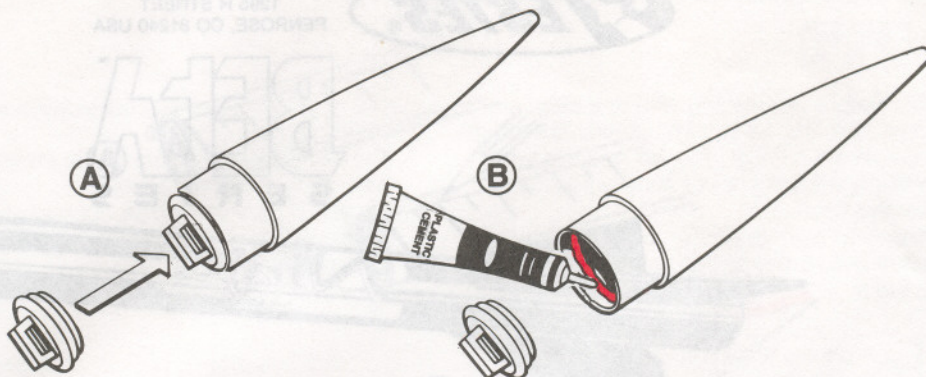

2. ENGINE MOUNT ASSEMBLY



- A. You will need the blue engine mount tube, engine hook and green adapter ring.
- B. Locate the ruler printed in the center crease of this instruction sheet.
- C. Lay one end of the engine mount tube on the zero mark of the ruler.
- D. Take your pencil and place a mark on the engine mount tube at 19 mm (3/4") from zero. Make another mark at 38 mm (1 1/2") from zero.
- E. Cut 3 mm (1/8") slit as shown at the 38 mm (1 1/2") mark only.
- F. Insert the engine hook into the slit as shown. The engine hook should extend beyond the rear of the engine tube.
- G. Test fit the green adapter ring by sliding it onto the front of the engine tube. Slide the ring over the engine hook and up to the 19 mm (3/4") mark you made in step D.
- H. Once the ring is in place, apply glue to both sides of the ring. Set assembly aside to allow to dry.

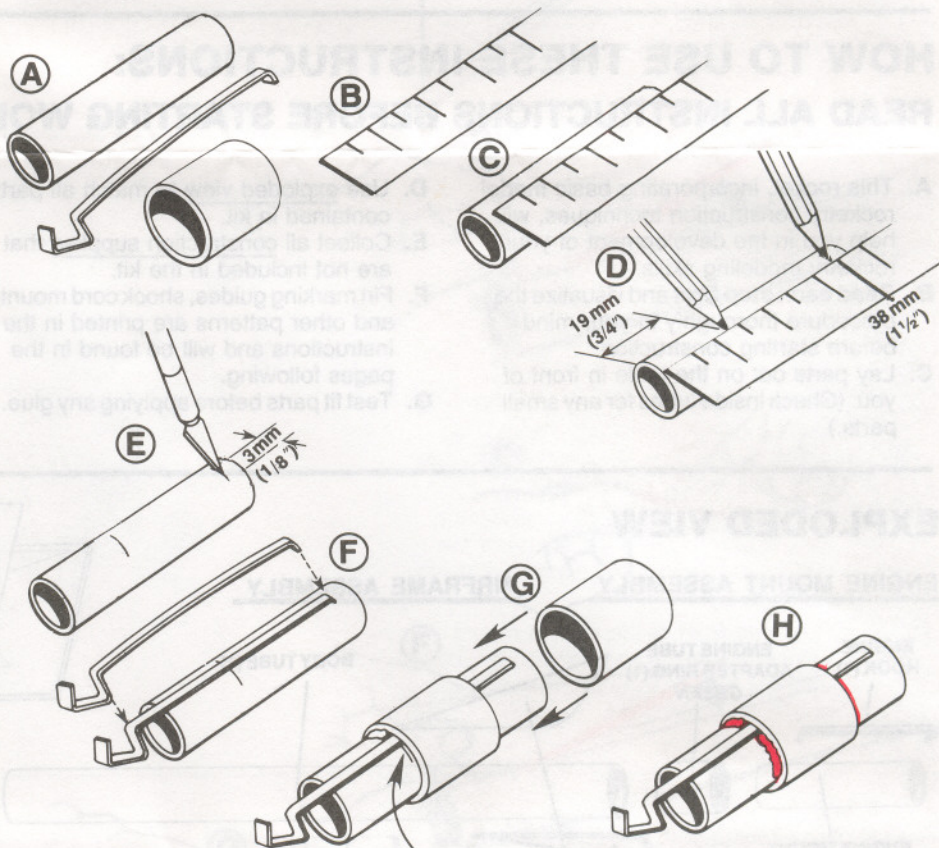

3. SHOCK CORD MOUNT ASSEMBLY



- A. Locate the shock cord mount on the bottom of page six in the patterns section.
- B. Cut out the shock cord mount along the solid black outline.
- C. Crease on dotted lines by folding.
- D. Spread glue on section 2 and lay end of shock cord into glue at a slight diagonal as shown.
- E. Fold section 1 forward. Apply glue to section 3. Fold forward again.
- F. Clamp firmly with your fingers for 2 minutes until glue dries. Set aside until step 10.

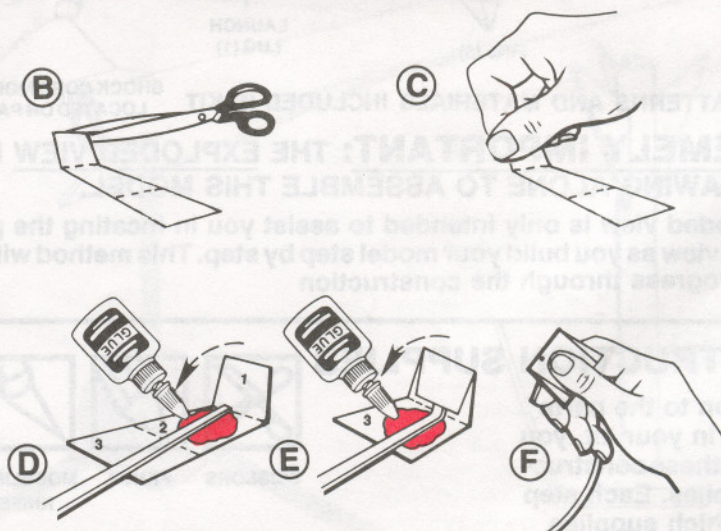

4. FIN PREPARATION



NOTE: Before proceeding with this step:

- Since your fins are not completely cut out of the white card stock, you will need to **work carefully** with your hobby knife to free the fins from the card.
- Be sure to cut completely around each fin outline before attempting to remove fins from the card.

- Check both sides of the card to make sure you cut through.
- Pay close attention to the corner areas where die cutting is not complete.
- As you cut around each fin, cut away from the adjacent fins so you will not damage the other fins on the card.

- A. Free the fins from the card stock with your hobby knife.
- B. Keep a piece of scrap card to use as a glue applicator in step 5.
- C. Lay sandpaper, rough face up, on your table. Stack your fins together and lightly sand all edges smooth and flat.

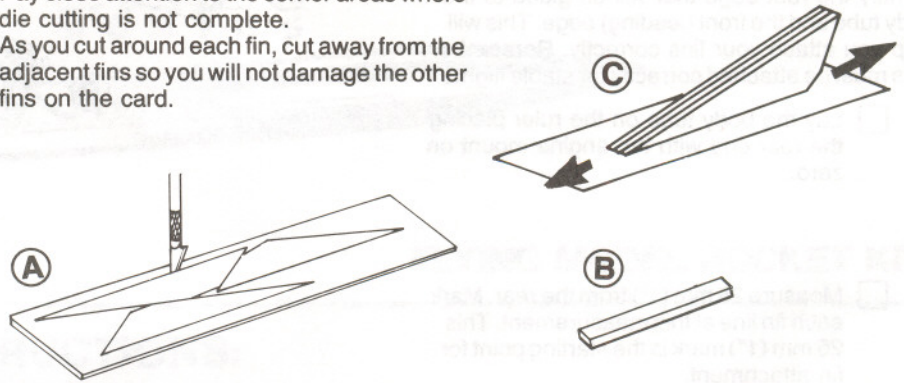

5. ENGINE MOUNT INSTALLATION



- A. Locate the body tube.
- B. Measure approximately 19 mm (3/4") from one end of the body tube. This gives you an idea of where inside the tube you will be spreading glue.
- C. Using the scrap card glue applicator, spread glue around the inside of the tube at approximately 19 mm (3/4") from the end.
- D. Push the front of the engine mount assembly into the end of the body tube until the engine tube is even with the end of the body tube.

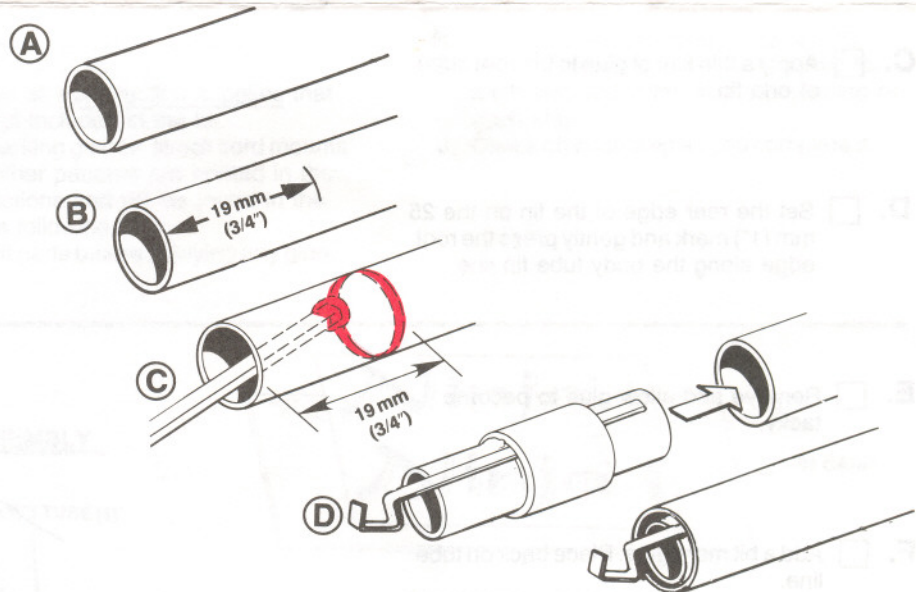

6. TUBE MARKING DETAIL



HINT: Fins can be glued on easier by lightly sanding the body tube with #600 grit sandpaper. Do this before you mark the body tube.

- A. Locate the tube marking guide on the bottom of page six in the patterns section. Cut the guide along the outline.
- B. Wrap the guide around the body tube and tape it in place around the same end that contains the engine mount.
- C. Mark tube at all arrow locations. One line on your tube marking guide is labeled LL, this means Launch Lug. Write LL on the body tube for that line. Remove marking guide.
- D. Using a door frame as a guide, draw straight lines connecting each pair of fin marks. Extend these lines 102 mm (4") along the tube. Draw a 76 mm (3") line along the tube for the launch lug.

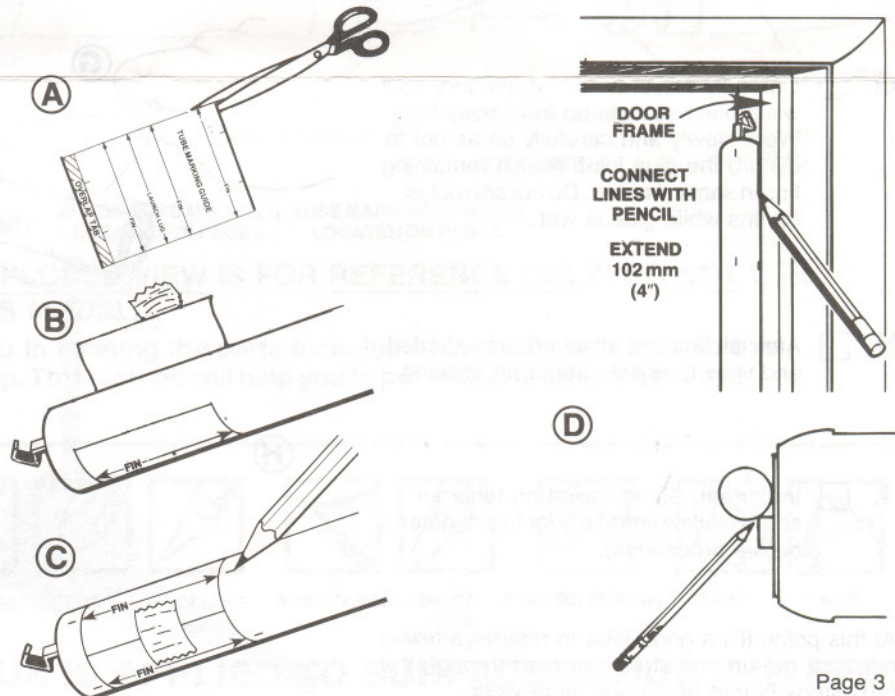

7. FIN ATTACHMENT



NOTE: Before gluing your fins, match the fin shape to the fin pattern shown in this step. Identify the root edge that will be glued to the body tube and the front (leading) edge. This will help you attach your fins correctly. **Remember:** Fins must be attached correctly for stable flights.

- A. Lay the body tube on the ruler placing the rear end with the engine mount on zero.
- B. Measure 25 mm (1") from the rear. Mark each fin line at this measurement. This 25 mm (1") mark is the starting point for fin attachment.
- C. Apply a thin film of glue to the root edge of one fin.
- D. Set the rear edge of the fin on the 25 mm (1") mark and gently press the root edge along the body tube fin line.
- E. Remove and allow glue to become tacky.
- F. Add a bit more glue. Place back on tube line.
- G. Carefully adjust the fin, if needed, so it will project straight up from body tube. Work slowly and carefully so as not to disturb the glue joint. Attach remaining fins in same manner. Do not set rocket on fins while glue is wet.
- H. After all fins are attached, use shaded end view to check proper fin spacing.
- I. Important: Stand rocket on table as shown. Allow fins to dry for five minutes before proceeding.

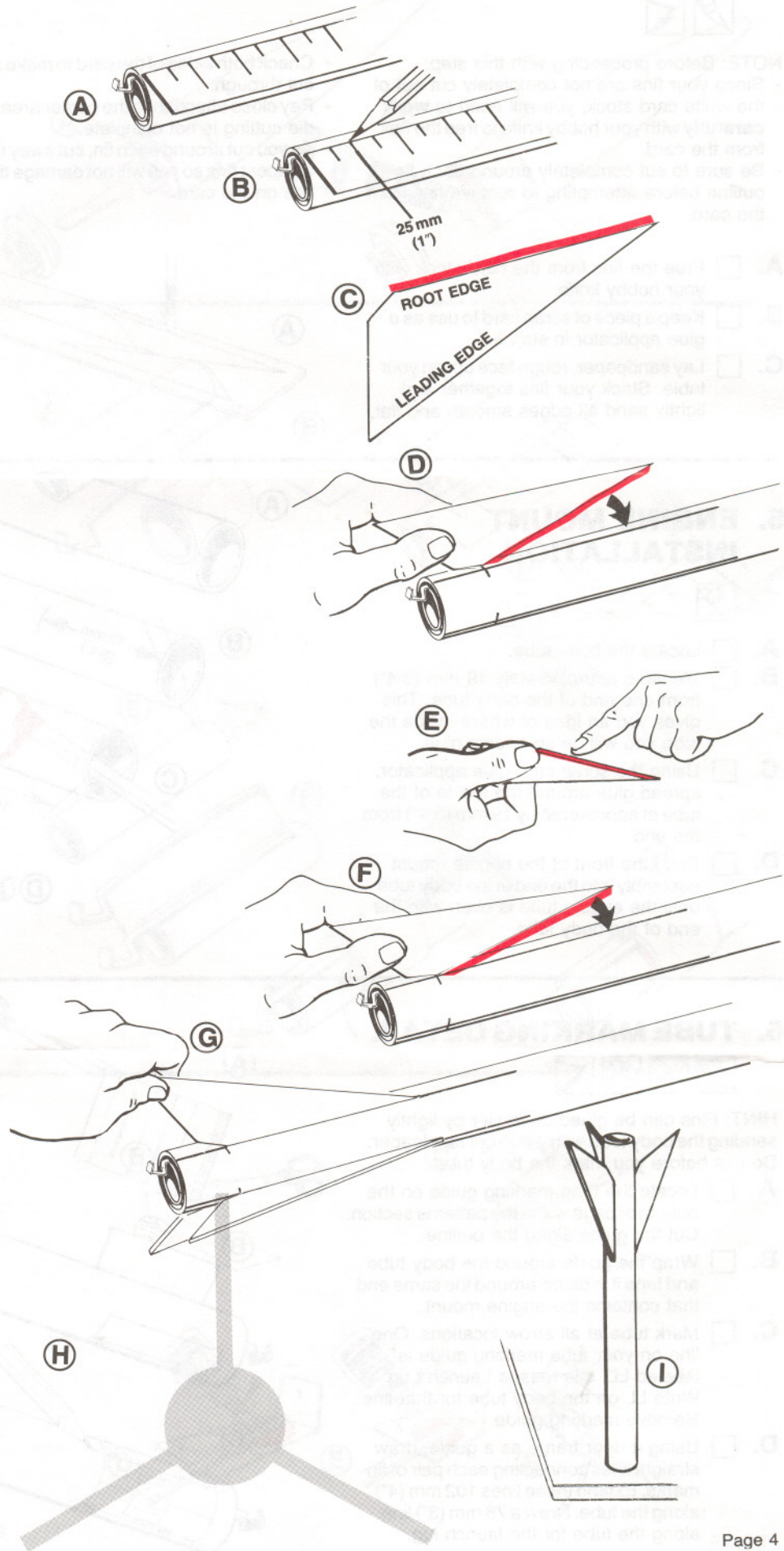

At this point, it's a good idea to rest for a few minutes, get up and stretch or read through the next steps before doing any more work.

8. LAUNCH LUG ATTACHMENT

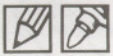

- A. Measure approximately 38 mm (1½") from rear of body tube and place a mark on the launch lug (LL) reference line. Use this mark as a starting point to attach the launch lug.
- B. Apply glue to the launch lug and attach it to the body tube.
- C. Make sure the launch lug is aligned with the body tube as shown on the end view. Allow to dry.

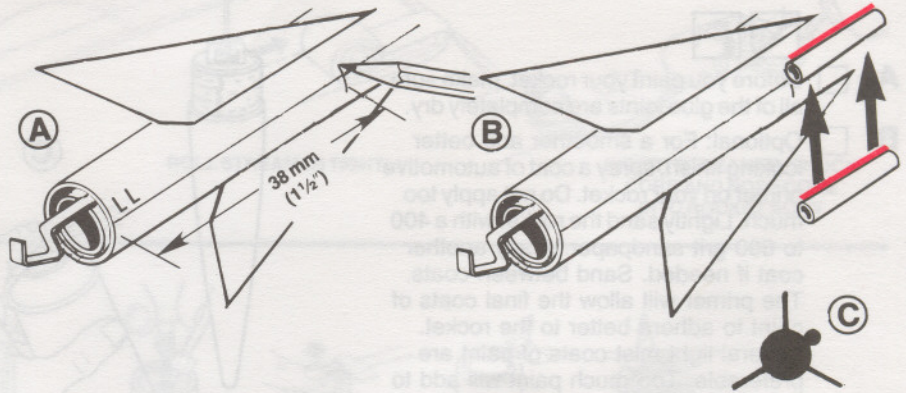

9. GLUE REINFORCEMENT DETAIL



NOTE: Glue joint reinforcements or fillets are important because they help blend the fins, launch lugs or other components into the body tube. This blending improves the looks of your model, allows smoother air flow over your rocket during flight and strengthens the attachment points.

- A. Reinforce each fin/body tube joint with glue and each side of launch lug as shown. Use your finger to help smooth the glue (fillet).
- B. Stand rocket on table as shown to allow glue to dry for approximately five minutes. Wipe away any excess glue that may run down the side of the body tube. Allow glue to dry.

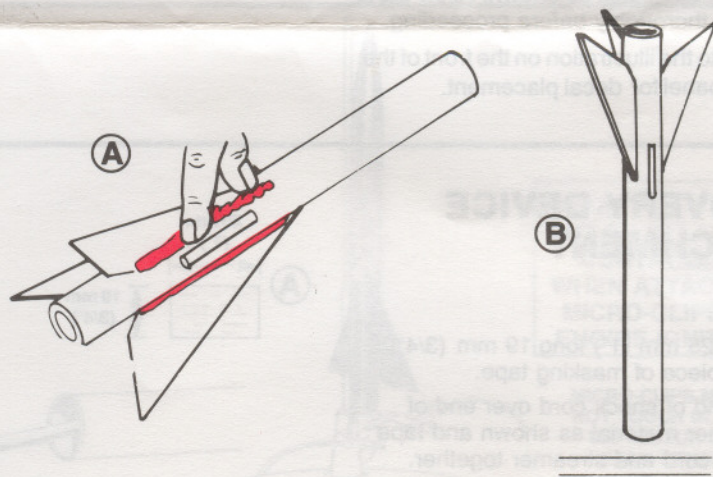

10. SHOCK CORD MOUNT ATTACHMENT



- A. Measure approximately 25 mm (1") from the front end of the body tube.
- B. Apply glue to the shock cord mount and insert into tube.
- C. Set the mount back at least 25 mm (1") to allow for nose cone clearance and press mount firmly into glue as shown.
- D. Hold until glue sets.

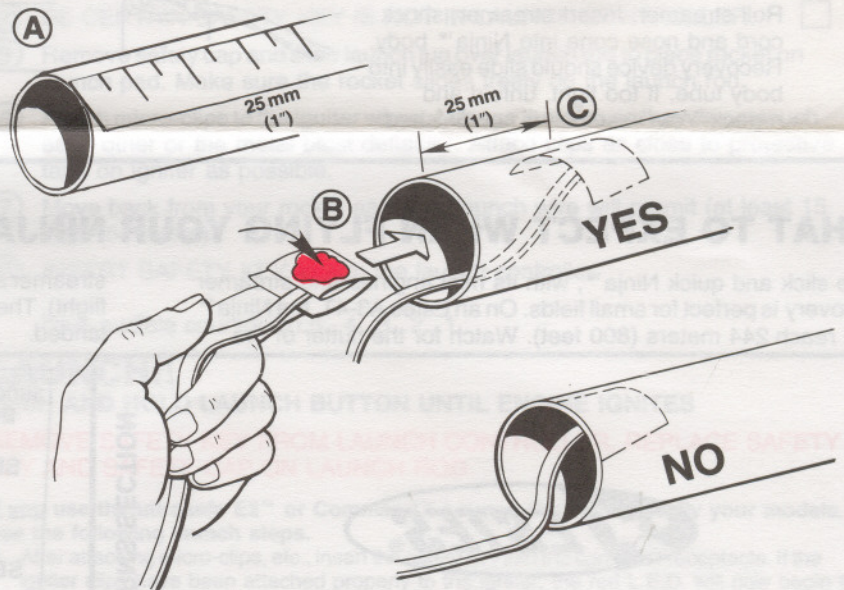

11. PAINTING YOUR ROCKET



- A. Before you paint your rocket, make sure all of the glue joints are completely dry.
- B. Optional: For a smoother and better looking finish, spray a coat of automotive primer on your rocket. Do not apply too much. Lightly sand the rocket with a 400 to 600 grit sandpaper. Apply another coat if needed. Sand between coats. The primer will allow the final coats of paint to adhere better to the rocket. Several light mist coats of paint are preferable. Too much paint will add to the rocket's weight.
- C. Mask the shoulder with tape to prevent overspray. Suspend nose cone from a string and paint red. Allow to dry.
- D. Paint body black as shown. Allow parts to dry thoroughly before proceeding.
- E. Refer to the illustration on the front of the color panel for decal placement.

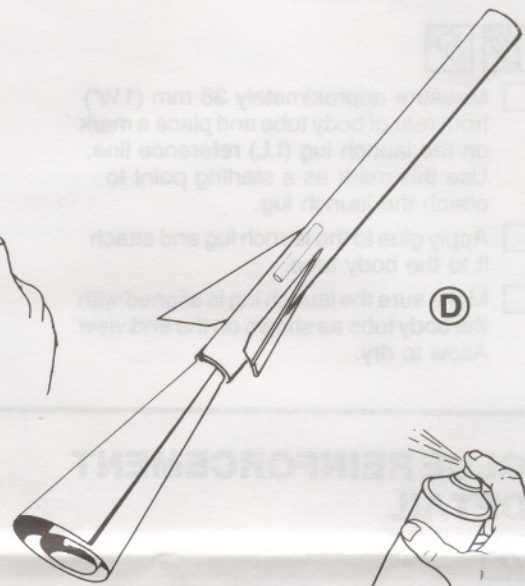

12. RECOVERY DEVICE ATTACHMENT



- A. Cut a 25 mm (1") long 19 mm (3/4") wide piece of masking tape.
- B. Lay end of shock cord over end of streamer material as shown and tape shock cord and streamer together.
- C. Press tape down firmly to assure a strong bond.
- D. Tie free end of shock cord to nose cone. Use a double knot.
- E. Roll streamer, shock cord and nose cone into Ninja™ body. Recovery device should slide easily into body tube. If too tight, unfold and repack. Your assembly is now finished.

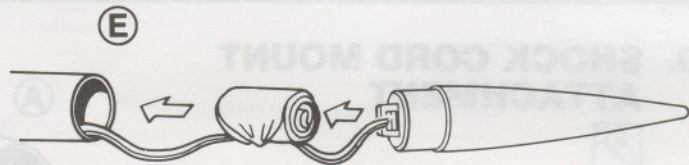
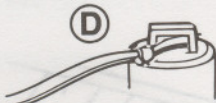
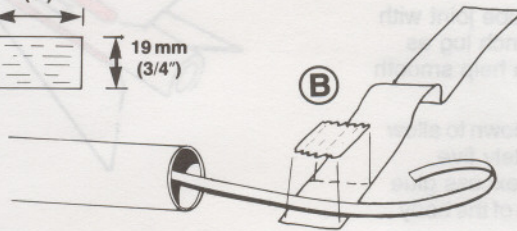
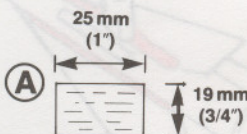

WHAT TO EXPECT WHEN FLYING YOUR NINJA™ ROCKET

The slick and quick Ninja™, with its mini engines and streamer recovery is perfect for small fields. On an Estes A3-4T, the Ninja™ will reach 244 meters (800 feet). Watch for the flutter of the

streamer as it is ejected at apogee (the highest point in the rocket's flight). The streamer will also help you find your rocket once it has landed.



PATTERNS SECTION

SHOCK CORD MOUNT
SEC. 3
SEC. 2
SEC. 1

OVERLAP TAB

TUBE MARKING GUIDE
FIN
LAUNCH LUG
FIN
FIN

ROCKET PREFLIGHT

CRUMPLE AND INSERT
3 SQUARES OF
RECOVERY WADDING

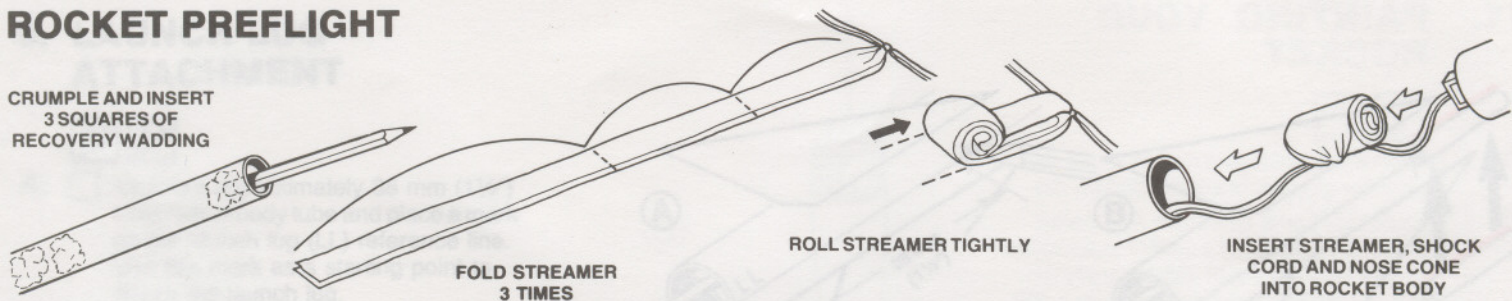

PREPARE ENGINE

NOTE: Igniter plugs come with rocket engines. If your engines did not come with plugs, follow the instructions that came with the engines.



SEPARATE IGNITER AND
IGNITER PLUG

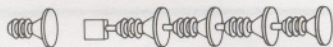

HOLD ENGINE UPRIGHT,
DROP IN IGNITER



IGNITER
MUST
TOUCH
PROPELLANT



INSERT
IGNITER
PLUG

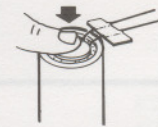

FIRMLY PUSH
ALL THE WAY IN

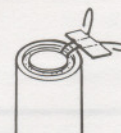

BEND
IGNITER
WIRES BACK



INSERT
ENGINE INTO
ROCKET

LAUNCH SUPPLIES

To launch your rocket you will need the following items:

—Estes Electrical Launch Controller and Launch Pad

—Recommended Estes Engines: 1/2A3-4T, A10-3T

—Estes recovery wadding #2274

To become familiar with your rocket's flight pattern, use a 1/2A3-4T engine for your first flight.

Use only Estes products to launch this rocket.

FLYING YOUR ROCKET

Choose a large field away from power lines, tall trees, and low flying aircraft. Try to find a field at least 250 feet (76 meters) square. The larger the launch area, the better your chance of recovering your rocket. Football fields and playgrounds are great.

Launch area must be free of dry weeds and brown grass.

Launch only during calm weather with little or no wind and good visibility.

MISFIRES

If the igniter functions properly but the propellant does not ignite, keep in mind the following: An Estes igniter will function properly even if the coated tip is chipped. However, if the coated tip is not in direct contact with the engine propellant, it will only heat and not ignite the engine.

When an ignition failure occurs, remove the safety key from the launch control system and wait one minute before approaching the rocket. Remove the expended igniter from the engine and install a new one. Be certain the coated tip is in direct contact with the engine propellant, then reinstall the igniter plug as illustrated above. Repeat the countdown and launch procedure.

FOR YOUR SAFETY AND ENJOYMENT

Always follow the NAR* MODEL ROCKETRY SAFETY CODE while participating in any model rocketry activities.

*National Association of Rocketry

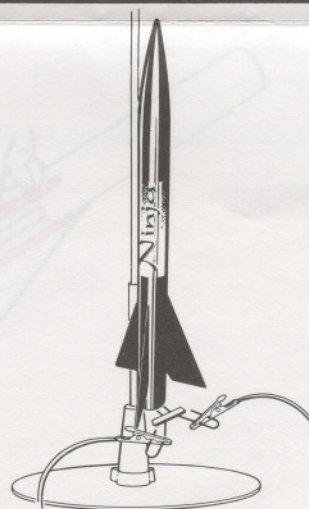

SAFETY KEY MUST NOT BE IN LAUNCH CONTROLLER WHEN ATTACHING MICRO-CLIPS TO ENGINE IGNITERS

MICRO-CLIPS MUST NOT TOUCH BLAST DEFLECTOR OR EACH OTHER

COUNTDOWN AND LAUNCH

- 10 BE CERTAIN SAFETY KEY IS NOT IN LAUNCH CONTROLLER.
- 9 Remove safety cap and slide launch lug over launch rod to place rocket on launch pad. Make sure the rocket slides freely on the launch rod.
- 8 Attach micro-clips to the igniter wires. Arrange the clips so they do not touch each other or the metal blast deflector. Attach clips as close to protective tape on igniter as possible.
- 7 Move back from your rocket as far as launch wire will permit (at least 15 feet - 5 meters).
- 6 INSERT SAFETY KEY to arm the launch controller.

Give audible countdown 5...4...3...2...1

LAUNCH!!

PUSH AND HOLD LAUNCH BUTTON UNTIL ENGINE IGNITES

REMOVE SAFETY KEY FROM LAUNCH CONTROLLER. REPLACE SAFETY KEY AND SAFETY CAP ON LAUNCH ROD.

If you use the ultrasafe E2™ or Command™ Launch Controllers to fly your models, use the following launch steps.

- After attaching micro-clips, etc., insert the safety key into the controller receptacle. If the igniter clips have been attached properly to the igniter, the red L.E.D. will now begin to flash on and off and the audio continuity indicator will beep on and off.
- Hold the yellow (left) arm button down. The L.E.D. will stop flashing and the audio indicator will produce a steady tone.
- Verbally count down from five to zero loud enough for the bystanders to hear. Still holding the yellow arm button down, push and hold the orange (right) button down until the rocket ignites and lifts off.

TODAY

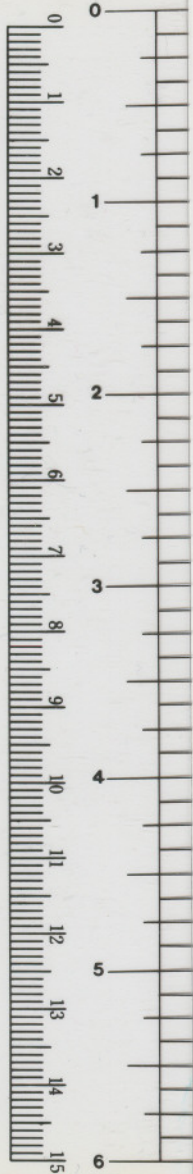

Quick Page Finder



ESTES

ESTES

PN 37388-1



BETA™

SERIES

NINJA™

Flying Model Rocket

SKILL LEVEL I

 Flies Up to
185 m (600 ft)

 Low Drag,
Lightning Quick!

Length: 268 mm (10.56 in.)

Diameter: 18.7 mm
(0.736 in.)

Weight: 15.9 g (0.56 oz.)

Recommended

Engines: 1/2A3-4T (First Flight), A3-4T, A10-3T

Assembly Requires (not included): Hobby tools, glue (white or yellow), plastic tube type cement, paint

MADE IN USA

EST 0882



0 47776 00882 3



ESTES INDUSTRIES
1295 H STREET
PENROSE, CO 81240

PN 82495

NINJA



ESTES
PN 37388



NINJA



PN 37388-1