



STINGER

FLYING MODEL ROCKET

SKILL LEVEL 1

1-Beginner 2-Intermediate 3-Craftsman
4-Advanced 5-Expert

- Flights To 1000 Feet
- High Performance Sport Model
- Die-Cut Balsa Parts
- Quick Release Engine Mount
- Plastic Nose Cone
- Streamer Recovery

Length: 13.5 in. (34.3 cm)

Dia.: .976 in. (24.8 mm)

Weight: .98 oz. (28 g)

Engine Types:

A3-3 (First Flight), B4-1,

D6-4, R6-5, C6-5

This is a hobby kit requiring assembly. Recommended for ages 10 to adult. Engines, launch system, glue and finishing supplies are not included. Adult supervision is suggested for those under 12 years of age when flying model rockets.



#1905

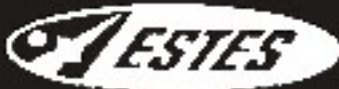

A Division of

ESTES INDUSTRIES
PENROSC, CO 81240 USA

ESTES STINGER

SKILL LEVEL 1 - Recommended for Beginning Rocketeers

RECOMMENDED ENGINES:
A8-3, B4-4, B6-4, B8-5 and C6-5
First Flight A8-3

BEFORE YOU START

Read each step and study the accompanying drawings before doing any of the work called for in that step. Make sure you have all parts and materials. Check off each step as you complete it. Always test-fit parts together before applying glue. It will sometimes be necessary to sand edges of rings, tubes, etc. to obtain a proper fit. If you are in doubt about the relative size or location of some parts, refer back to this exploded view drawing for clarification. Adequate glue joints are very important for a flying model rocket. Follow the instructions carefully in this regard.

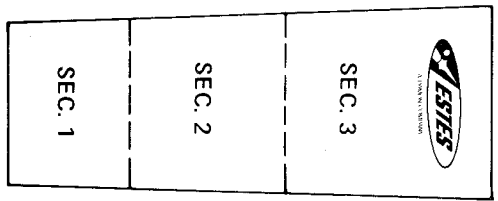
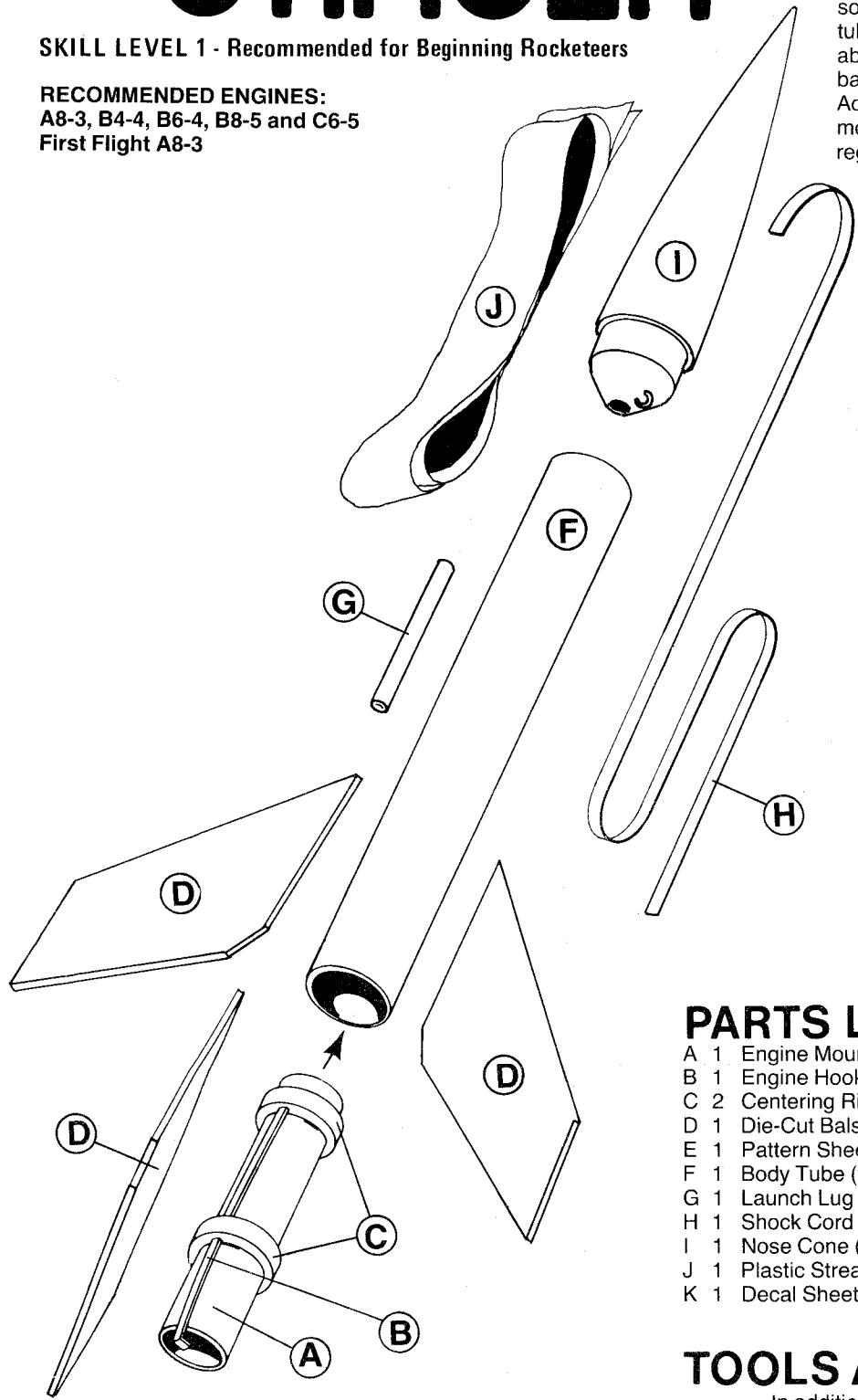
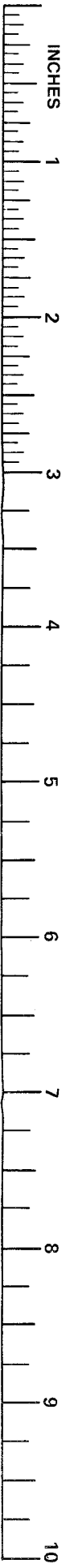

SHOCK CORD MOUNT
(to be cut out here)

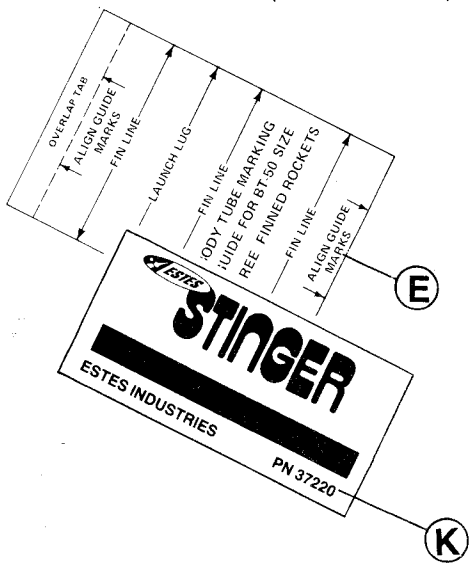

PARTS LIST

KIT # 1905

A	1	Engine Mount Tube (type BT-20J)	30326
B	1	Engine Hook (type EH-2)	35025
C	2	Centering Rings (type AR-2050)	30164
D	1	Die-Cut Balsa Sheet (type BF-1905)	32605
E	1	Pattern Sheet	83626
F	1	Body Tube (type BT-50H)	30360
G	1	Launch Lug (LL-2A)	38175
H	1	Shock Cord (type SC-1)	85730
I	1	Nose Cone (type PNC-50Y)	71009
J	1	Plastic Streamer (type RS-20)	38278
K	1	Decal Sheet (type KD-1905)	37220

TOOLS AND MATERIALS

In addition to the parts included in this kit you will need: Scissors, pencil, ruler, fine or extra-fine grit sandpaper, sanding sealer, a medium-size modeling paint brush, modeling knife with sharp blade, gloss white and orange enamel spray paints and household white glue or resin glue (Elmer's, Titebond, or similar). Other types of glue are not recommended.

For easy and positive alignment of the fins on your model, we recommend the use of Estes' Fin Alignment Guide, Part No. 2231.



ESTES INDUSTRIES
PENROSE, CO 81240 USA

1

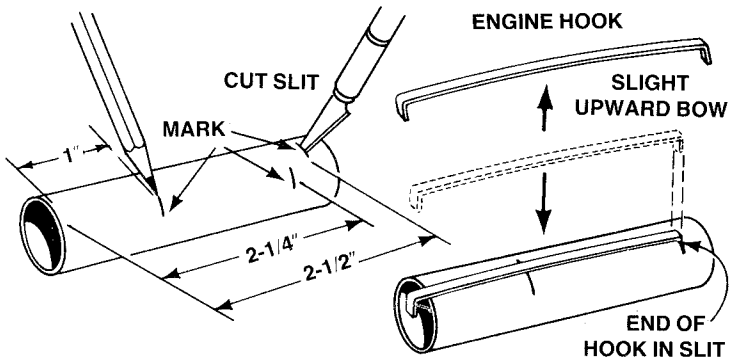

Mark the engine mount tube (part A) at 1", 2-1/4", and 2-1/2" from one end. Cut a 1/8" long slit at the 2-1/2" mark. Gently bend the engine hook (part B) so that it bows upward very slightly in the middle. (Study the drawing — Don't bend the wrong way.) Insert one end of the engine hook into the slit in the tube.

2

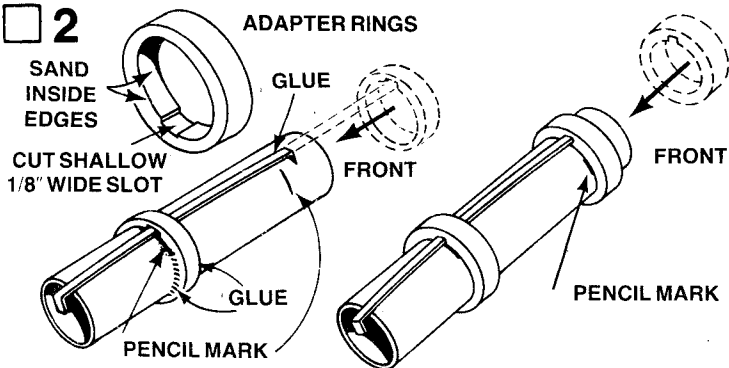

Sand the inside edges of the two centering rings (part C) to remove burrs. The rings should slide easily onto the engine mount tube. Cut a very shallow 1/8" wide slot inside the two centering rings so they will fit over the engine hook. Slip one ring onto the forward end of the engine mount tube and slide it down to the 1" mark. Make sure the engine hook runs straight down the tube, then apply glue to both sides of this ring. Apply glue around the tube at the 2-1/4" mark and slide the remaining centering ring into place down to the 2-1/4" mark.

3

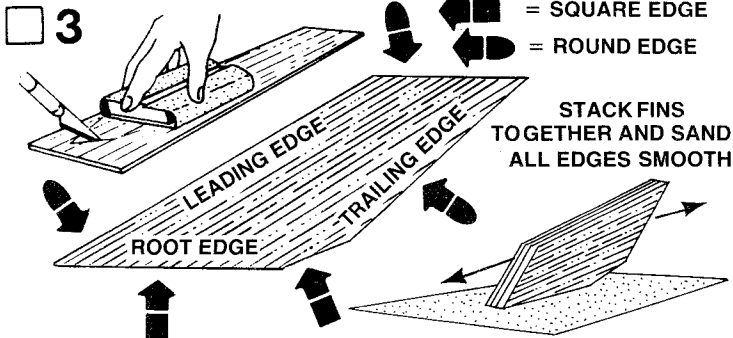

Fine-sand the balsa die-cut sheet (part D), then carefully remove the die-cut fins from the sheet. Free the edges with a sharp knife. Sand the leading and trailing edges of the fins round. Leave other edges square.

4

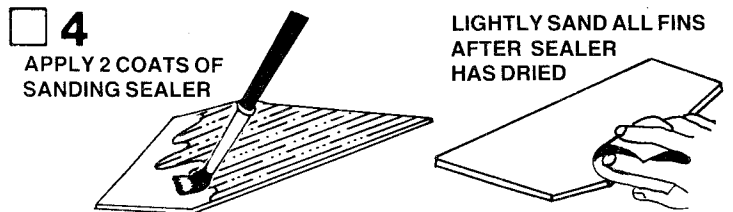

Apply a coat of sanding sealer to each fin. Apply sealer to all edges except the root edge. When sealer is dry, lightly sand all the sealed surfaces. Repeat sealing and sanding process until balsa grain no longer shows. Resand root edge, lightly, to remove any trace of sealer.

5

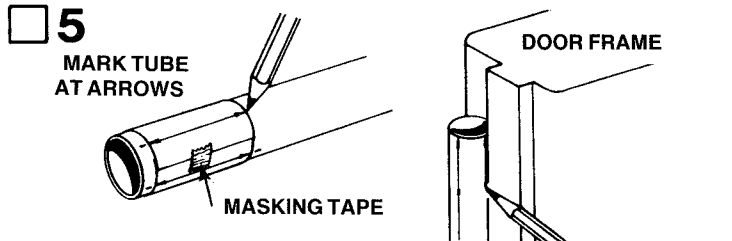

Cut out the tube marking guide (part E) and wrap it around the body tube (part F). Mark the body tube at each of the arrow points. Draw straight lines connecting each mark. A door frame inside edge can be used as a guide as shown. Extend the lines about 6" up from the rear of the tube.

6

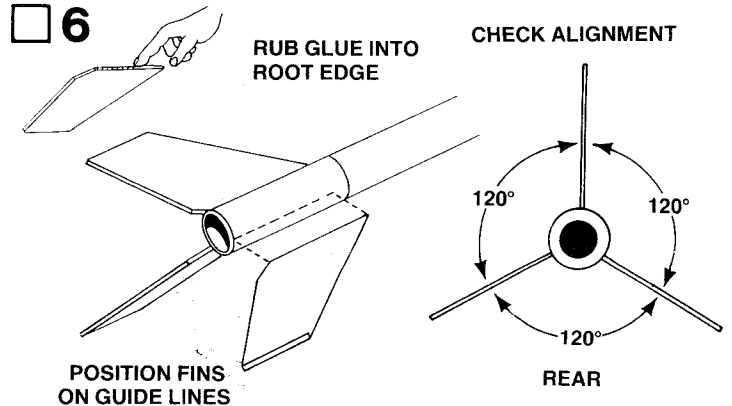

Rub a line of glue into the root edge of each fin and allow to dry. Apply glue to the fins and position fins on the alignment lines in their correct positions on the tube. Refer to the illustration to be sure of these positions. Adjust the fins so they project straight away from the body tube. Do not set the rocket on its fins while the glue is wet.

7

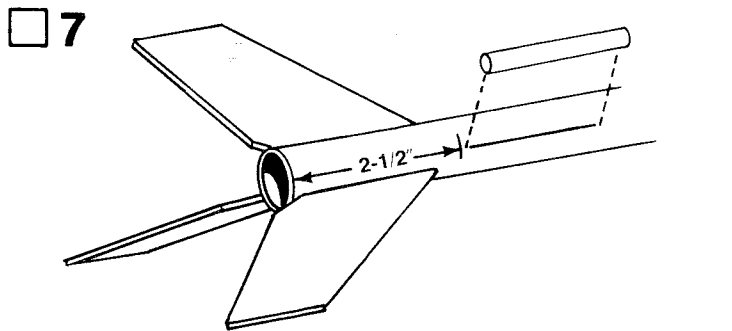

Glue launch lug (part G) to rocket body tube on the launch lug line. The rear of the launch lug should be 2-1/2" from the rear of the rocket body tube. Align the launch lug straight along the body.

8

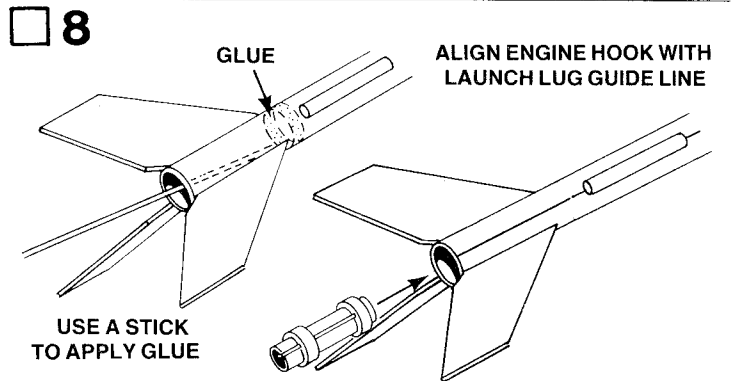

Apply a ring of glue around inside of rear end of body tube about 2" to 2-1/2" from the end of the tube. Use a stick or dowel as shown. Immediately insert the engine mount unit, being careful to position it so the engine hook will stick out of the end of the tube. Push engine mount in with one smooth motion until the end of the engine mount and the end of the body tube are even.

□ 9

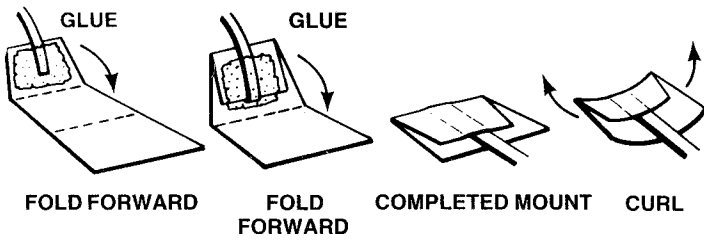

Cut out the shock cord mount from the front page of the instructions. Crease it on the dotted lines by folding. Spread glue on the first section (1) and lay the end of the shock cord (part H) into the glue. Fold over and apply glue to the back of the first section and the exposed part of section 2. Lay the shock cord as shown and fold over again. Clamp the unit together with your fingers until the glue sets.

□ 10

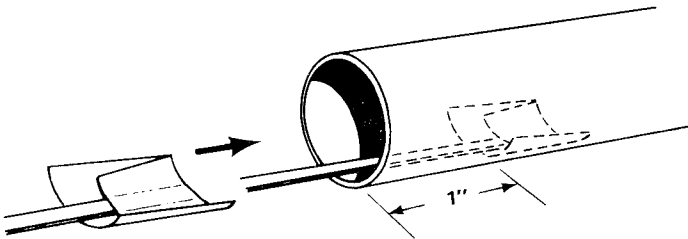

SMEAR A FILM OF GLUE OVER MOUNT AND SURROUNDING AREA INSIDE THE BODY TUBE

Use a stick or scrap dowel to apply a generous amount of glue inside the body tube 1" from the front of the tube for the nose cone to socket into place. Slide the shock cord mount into the tube and press it into the glue. To insure a good bond use a stick or your finger to smear a film of glue over the mount and surrounding area in the body tube.

□ 11

APPLY GLUE REINFORCEMENT

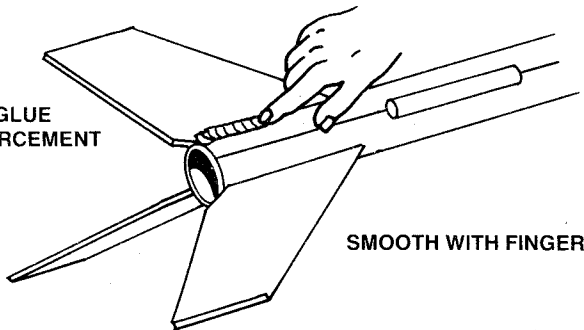

SMOOTH WITH FINGER

Apply glue reinforcements to each fin/body tube joint. Holding the model level, apply a narrow line of glue to both sides of each fin joint. Smooth out the glue with your finger. Apply glue reinforcement on both sides of launch lug. **IMPORTANT** -- Keep the model level until the glue dries.

□ 12

CLEAR EYELET

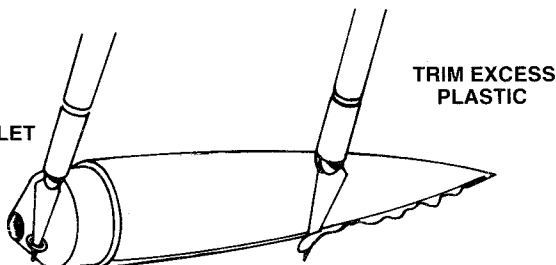

TRIM EXCESS PLASTIC

Trim or sand any excess plastic from around the sides of the nose cone (part I). Use a sharp knife to remove any excess plastic from the inside of the molded eyelet at the rear of the nose cone. Wash the nose cone with lukewarm soapy water, rinse well, and dry.

□ 13

USE ROLLED PAPER FOR ROCKET HOLDER

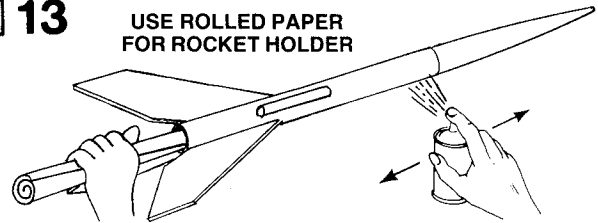

After all the glue is completely dry, paint the entire model gloss white. Follow instructions on the spray can for best results. We recommend spray enamel. Do not paint the model with lacquer paint. Shake can before spraying. Hold the can straight up and spray in long, smooth "strokes". Spray the model with several light, dry mist coats of paint to avoid "runs". Shake can periodically. To obtain a gloss, final coat should be applied slightly heavier. Let this coat dry overnight.

□ 14

NOTE: APPLY FINAL COAT WITH "WET" LOOK

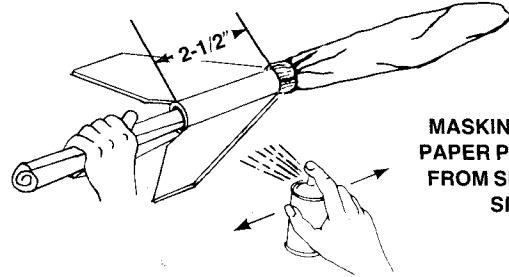

MASKING TAPE AND PAPER PROTECT MODEL FROM SECOND COLOR SPRAY

Apply masking tape and paper to cover and protect the areas which will remain white (See the Decor Layout illustration.) Paint the fins and rear of the body tube bright orange. Carefully remove the masking tape and paper as soon as the paint is dry.

□ 15

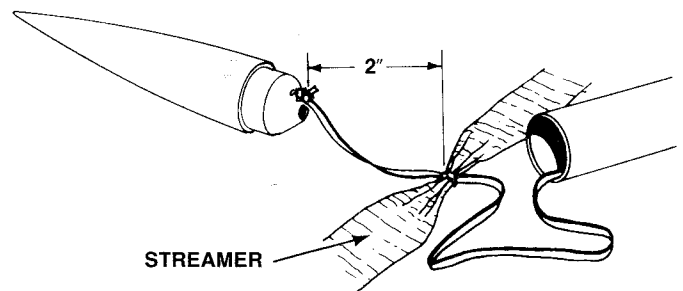

STREAMER

Using a double knot, tie the shock cord around the middle of the plastic streamer (part J) about 2" from the end of the shock cord. Attach the free end of the shock cord to the nose cone with a firm knot.

□ 16



When all paint is dry, apply the decals (part K) in the positions shown. (A) Cut only one decal at a time from sheet. (B) Submerge decal in lukewarm water until decal slides on backing paper (usually 15 to 30 seconds). (C) Gently slide decal from backing paper onto model. (D) Move decal into exact position and carefully blot away excess water with a soft cloth. (E) If the decal "sticks" before you have it in position, apply water over the decal with a brush. This will permit the decal to be moved. (F) Smooth out all wrinkles and air bubbles before the decal dries.

LAUNCHING COMPONENTS

To launch your rocket you will need the following items:
 An Estes model rocket launch system
 Parachute recovery wadding (Estes Cat. No. 2274)
 Recommended engines: A8-3, B4-4, B6-4, B8-5, and C6-5.
 Use an A8-3 engine for your first flight.

Be sure to follow the HIAA-NAR* Model Rocket Safety Code when carrying out your model rocket activities.

*HIAA—Hobby Industry of America
 *NAR—National Association of Rocketry

COUNTDOWN CHECKLIST

T-13

Pack 3 or 4 squares of loosely crumpled recovery wadding into the rocket body.

T-12

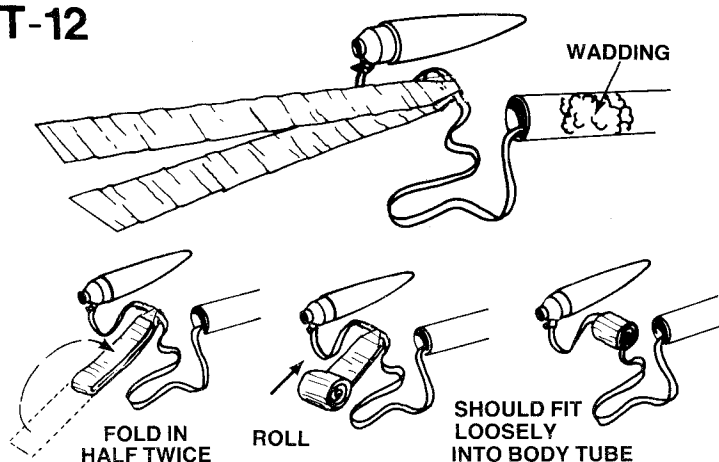

Fold the streamer in half lengthwise. Fold again, then roll until the streamer and shock cord fit loosely into the rocket body. Slide the nose cone into place.

NOTE: Nose cone should separate easily from rocket body tube, but should not be extremely loose. If fit is too tight, sand inside of body tube and shoulder of nose cone with fine sandpaper. If fit is too loose, add a wrapping of transparent tape or masking tape to the shoulder of the nose cone.

T-11

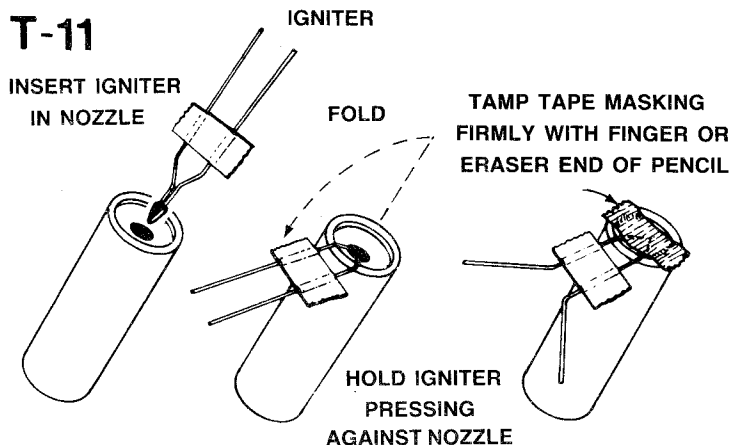

Select an engine and install an igniter as directed in the engine instructions. Use an A8-3 engine for your first flight.

T-10

MAKE SURE ENGINE HOOK LATCHES SECURELY

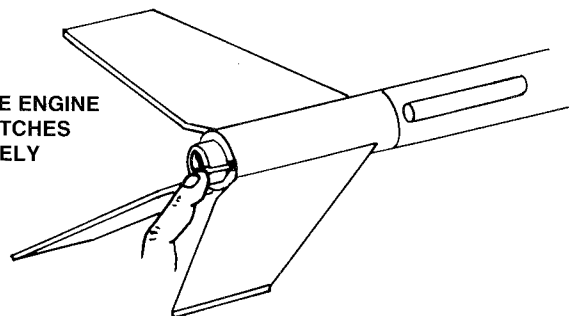

Insert engine into rocket engine mount. Engine hook must latch securely over end of the engine.

T-9

Disarm the launch panel -- REMOVE SAFETY KEY!

T-8

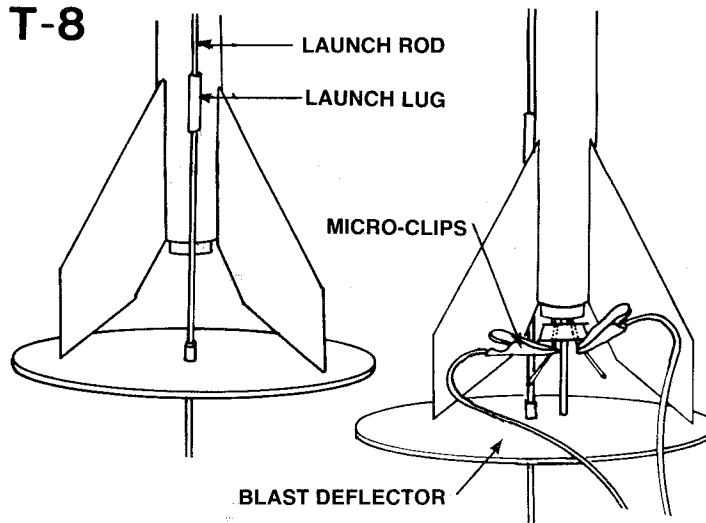

Slide launch rod through rocket launch lug and place rocket on launch pad. Make sure the rocket slides freely on the launch rod. Clean the micro-clips and attach them to the igniter wires. Arrange the clips so they do not touch each other or the metal blast deflector. Attach clips as close to engine as possible.

T-7

Clear the launch area, alert recovery crew and trackers. Check for low flying aircraft and unauthorized persons in the recovery area.

T-6

Arm the launch panel -- INSERT SAFETY KEY!

-5-4-3-2-1-LAUNCH!!

Repeat Countdown Checklist for each flight.

MISFIRE PROCEDURE

Disarm the launch panel. Wait one minute before approaching the rocket on the launch pad. Remove the rocket, clean the igniter residue from the nozzle of the engine, and carefully install a new igniter. Repeat the Countdown Checklist.

Failure of the rocket engine to function properly is nearly always caused by a failure to install the igniter correctly. This failure permits the igniter to heat and burn into two pieces without igniting the engine.

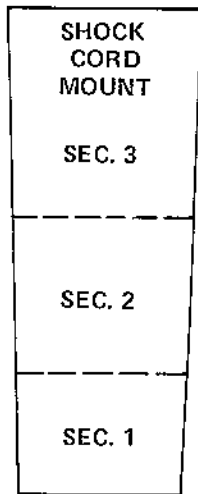
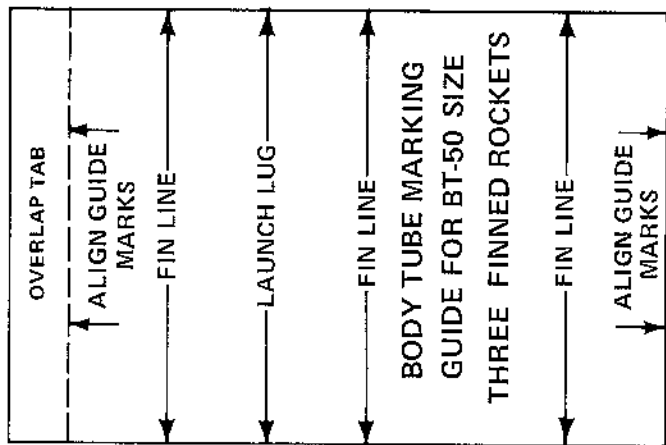

ESTES INDUSTRIES PN 83331 STANDARD SP-50A

Make three (3) fins from 3/32" balsa fin stock.

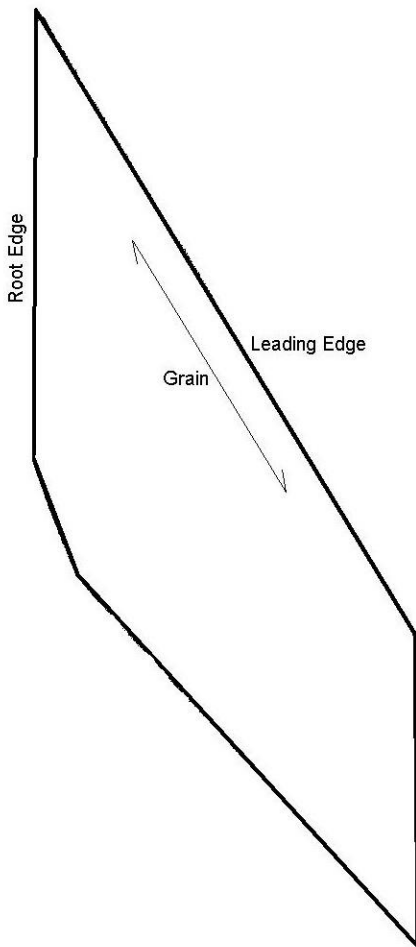



STINGER



ESTES INDUSTRIES

PN 37220