

NCK-29

Apollo Capsule with Escape Tower

DETAILED SHROUD
DIE-CUT PARTS

\$1.75



FITS
BT-70 TUBES

6.5" HIGH
(without adapter)

AVERAGE WEIGHT
36 OZ.

2 Versions YOU CAN BUILD!

Choice of

- SCALE LAUNCH VERSION
(With Complete Protective Cover)
- DISPLAY-FLIGHT VERSION
(Upper Protective Cover in place—
lower half of Command Module in view)

Another **Astron** Kit by



Industries, Inc.

Dedicated to Safety and Education in Rocketry

Box 227

PENROSE, COLORADO 81249

Parts List

A	Escape Motor nose cone	BNC-3A
B	Escape Motor tail cone	BTC-3
C	Capsule nose cone	BNC-2
D	Escape Motor tube	BT-3H
E	Tower structure material	WD-2
F	Ring set, Jig and Detail pieces	TA-29N
G	Capsule and nozzle shrouds	SP-29C
H	Screw eye	SE-1
I	12" Parachute kit	PK-12
J	Adapter collar	JT-70D
K	Sheet Balsa stock	BFS-40T

In addition to the parts listed above you will need scissors, a model knife or single edge razor blade, fine and extra fine sandpaper, white glue, some straight pins, white and black paint (a small bottle or can is enough), sanding sealer and a #2 brush. A piece of cellox or similar material one foot square (minimum) and a length of wax paper will also be useful.

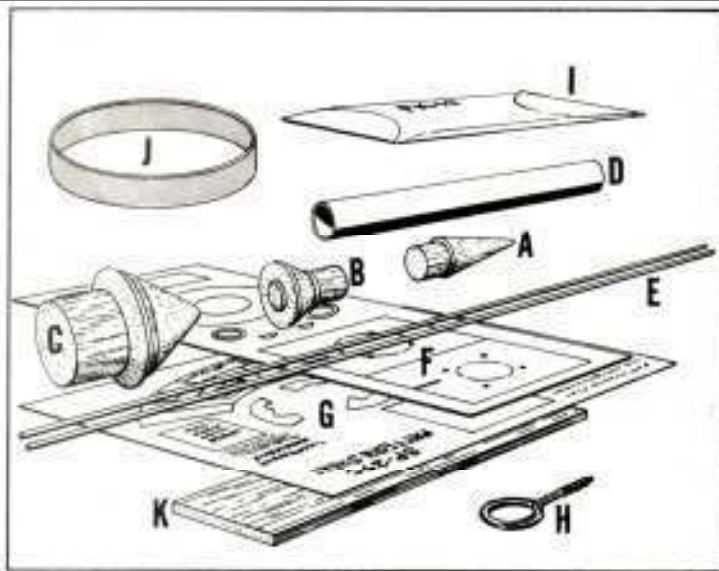

ESCAPE MOTOR UNIT

1. Apply glue to the inside of one end of the escape motor tube and slide the nose cone into place. Wipe off any extra glue that appears on the outside of the joint.

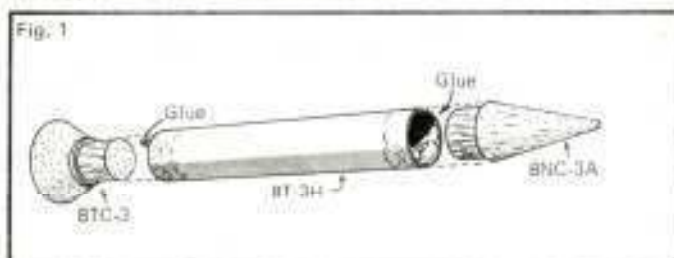

2. Apply glue just inside the other end of the escape motor tube and slip the tail cone into place as shown in fig. 1.

THE COMMAND MODULE

3. Decide which version of the Apollo command module you wish to make. The shroud has the details of the C/M printed, and although more interesting for display purposes, it is not "scale" for an actual liftoff. Cut out the shroud and form it as shown in fig. 2. If you have decided upon the liftoff version, form the shroud

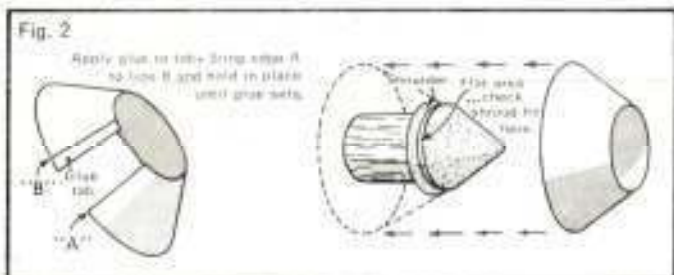

with the printed side to the inside. Slip the completed shroud over the capsule nose cone. It should seat against the shoulder of the cone, exposing about 1/16" of the flat area indicated.

4. Remove the large ring from the ring set and, with the shroud in place, slip the ring onto the base of the capsule cone. The ring should just fit inside the rear edge of the shroud all the way around. (Bevel the outer forward edge of the ring as shown as necessary to get the correct fit. See fig. 3.) Without disturbing the ring, remove the shroud. Run a fillet of glue around both sides of the ring-base joint and allow it to set. Next, run lines of glue around both the edge of the ring and the shoulder of the cone. Reseat the shroud against the ring's outer edge and the nose cone's shoulder and set the assembly aside to dry.

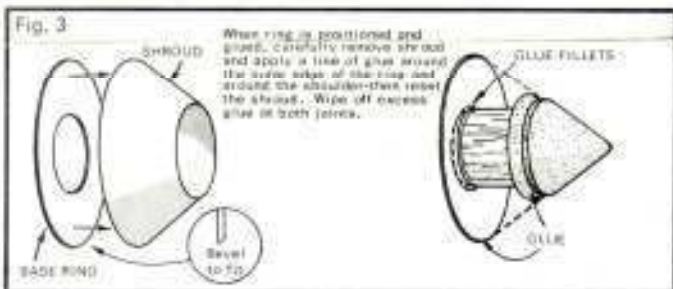

PREPARE TOWER STRUCTURE MATERIAL

5. Prepare the two dowels for use in the tower structure by carefully sanding one of them down to .058" diameter and sanding the other one down to .041" diameter. Hold one end of a dowel on a flat surface and, with sandpaper on a block, stroke the dowel, turn it slightly and stroke again...always away from you. Repeat this action until you have achieved the dimension you seek. When you have made one dowel of each size, proceed to step 6.

6. Position fig. 4 of this instruction sheet over the cellox board and cover the drawing with a piece of wax paper. You will construct two side frames of the tower structure over the SIDE VIEW drawing. The dots are the points where you will place the pins to brace and hold the vertical side members in place during step 7.

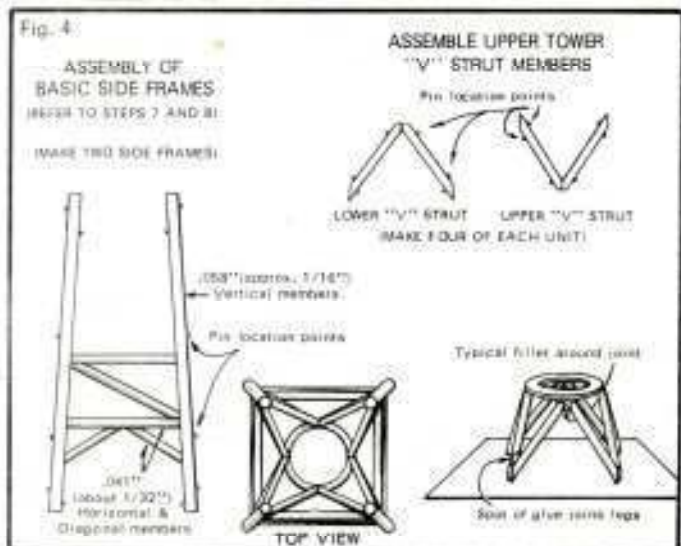

START THE TOWER STRUCTURE

7. Measure and cut two vertical members from the .058" (approximately 1/16") dowel by laying the dowel on the drawing and cutting to the length shown. Pin them in place as shown. Cut the bottom horizontal cross piece from the .041" (just over 1/32") dowel measuring the same general way as for the vertical pieces. Apply a small drop of glue to each end and fit it into place. Cut the upper cross member to length and glue it into position. Cut the diagonal member and glue it into place, followed by the two short diagonal braces below the bottom cross member.

8. After the glue has dried completely, remove the locating pins and carefully remove the first side frame. Replace the pins and repeat step 7. Again, after the glue has dried, remove the second side frame from the pins.

9. Assemble the tower structure jig to the side frames as shown in fig. 5. Note the positions of the cross and diagonal

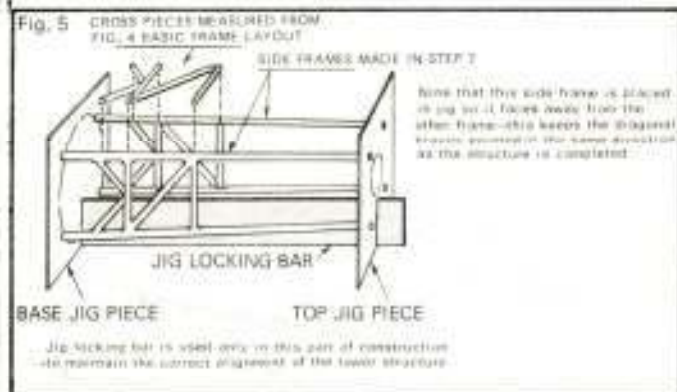

members in the drawing, then measure each piece and glue it in place as you did in step 7. When dry, remove the structure from the jig, turn the remaining side up, reassemble the jig and repeat the first two parts of this step. After the structure is completely dry, disassemble the jig from the structure and save the base and top jig pieces for use in the next steps.

10. Refer to fig. 4 for the upper tower structure drawings, and assemble four of each type of the "V" struts shown. When dry, glue the four lower "V" struts to one of the small rings, using the lower "V" strut assembly piece (cut from the SP-29C sheet) for leg spacing and support. Put a small drop of glue at each joint where the legs touch near the lower "V" strut assembly piece (be careful so you don't glue the legs to the piece). Put another drop of glue on the point of the "V" of each unit where it attaches to the ring. Repeat this step to glue the upper four "V" struts to the remaining ring, using the upper "V" strut assembly piece cut from the SP-29C sheet as before.

FINAL ASSEMBLY

11. Cut the ring from the center of the base jig piece and slip the jig piece over the nose cone of the capsule, aligning it as shown in fig. 6. Notch the nose cone through the four half-holes (actually pressing into the nose cone) with a scrap piece of 1/16"



dowel or a 1/16" drill bit. Apply a drop of glue to each notch and fit the base legs of the tower structure into place. Wipe off any excess glue and let the assembly dry completely.

12. Set the capsule/tower structure on a flat surface. Apply a drop of glue to each leg joint of the lower "V" strut assembly (this will assist in the four vertical side members) and slide the

unit into place inside the top of the structure, mating the ring surfaces and edges and with each leg joint in contact with a vertical side member. Set this entire assembly aside to dry completely.

14. Push the small disc from the center of the upper jig piece. Place the jig piece against the base of the escape motor tail cone, allowing the raised center of the cone to stick through. Mark the base of the cone through each of the four 1/16" holes with a pencil. Remove and discard the jig piece. Apply a spot

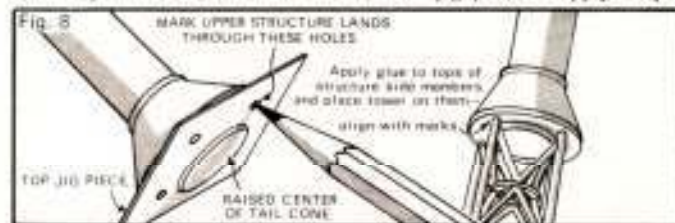

of glue to each mark and fit the escape motor assembly onto the top of the tower structure. Check the entire structure for correct alignment, then stand the assembly aside to dry completely. Apply a small fillet of glue to each joint of the tower structure and to the attachment points on the capsule cone and tower base. (Use a flat toothpick or a scrap 1/16" dowel for an applicator.)

15. Cut out the escape motor nozzle shrouds from the pattern sheet. Form each nozzle around the point of a 1/4" dowel or pencil sharpened with a standard (10" type) blade sharpener. (See fig. 9.) The irregular inner edge of a shroud matches up to give the proper angled base to each shroud when glued to the tower tail cone base between each of the "V" struts.

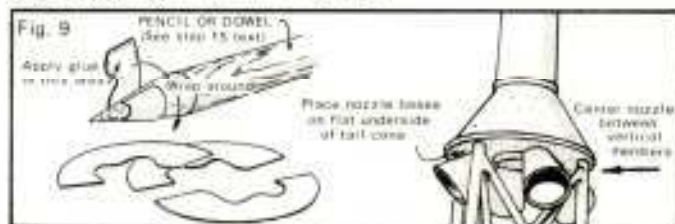

16. BE SURE TO FOLLOW THIS THREE-PART STEP IF YOUR MODEL IS TO BE FLOWN.

a) Apply glue to one edge of the adapter collar and center this collar on the base of the command module.

b) Insert the screw eye into the center of the base of the module. Remove the eye, squirt glue into the hole and replace the screw eye. Wipe off any excess glue from around the shaft.



c) Trace both patterns for the two-piece C/M to S/M umbilical onto the BFS-40T and cut them out. Cut and sand to the shape shown for each piece. Apply glue to the back of the C/M half and attach to the command module, centered in the panel to the right of the positive pitch engines (which are directly below the hatch window) and with the bottom edge even with the command module skirt. The S/M half of the umbilical is to be used on the tube which is to receive the command module. Orient the command module as it is to ride on your model, then apply glue to the back of the S/M half and attach it to the tube so the upper edge is butt-joined (but not glued) to the bottom edge of the C/M half of the umbilical.

NOTE: This Apollo kit is also used in the Uprated Saturn I kit. In that application the Service Module half goes 1/2" to the right of the reaction control system engines which are located above the POS. III fin, with its top edge even with the top edge of the tube. Install this piece before painting the Saturn I.

17. Fig. 11 shows the details for the fully shrouded lift-off version (your option in step 3) and the positions of the external details in relation to the hatch window. Details and colors given for the tower/escape motor assembly are correct for either version.

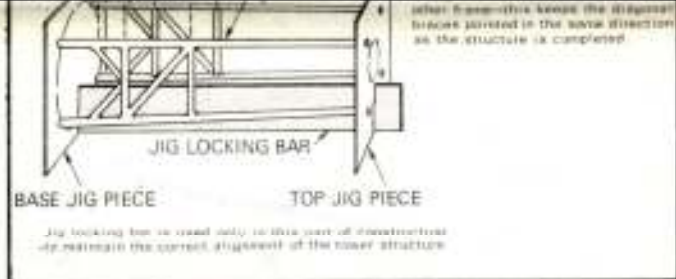

members in the drawing, then measure each piece and glue it in place as you did in step 7. When dry, remove the structure from the jig, turn the remaining side up, reassemble the jig and repeat the first two parts of this step. After the structure is completely dry, disassemble the jig from the structure and save the base and top jig pieces for use in the next steps.

10. Refer to fig. 4 for the upper tower structure drawings, and assemble four of each type of the "V" struts shown. When dry, glue the four lower "V" struts to one of the small rings, using the lower "V" strut assembly piece (cut from the SP-29C sheet) for leg spacing and support. Put a small drop of glue at each joint where the legs touch near the lower "V" strut assembly piece (be careful so you don't glue the legs to the piece). Put another drop of glue on the point of the "V" of each unit where it attaches to the ring. Repeat this step to glue the upper four "V" struts to the remaining ring, using the upper "V" strut assembly piece cut from the SP-29C sheet as before.

FINAL ASSEMBLY

11. Cut the ring from the center of the base jig piece and slip the jig piece over the nose cone of the capsule, aligning it as shown in fig. 6. Notch the nose cone through the four half-holes (actually pressing into the nose cone) with a scrap piece of 1/16"

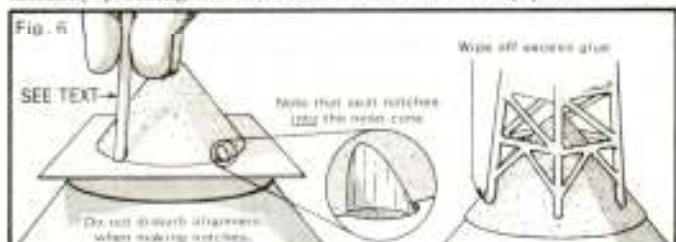

dowel or a 1/16" drill bit. Apply a drop of glue to each notch and fit the base legs of the tower structure into place. Wipe off any excess glue and let the assembly dry completely.

12. Set the capsule/tower structure on a flat surface. Apply a drop of glue to each leg joint of the lower "V" strut assembly (where it will contact the four vertical side members) and slide the assembly into place. The vertical members will be pliable enough to allow the strut assembly to be installed from the top of the structure. Make sure all strut legs position just at the top edge of the upper cross member joints.

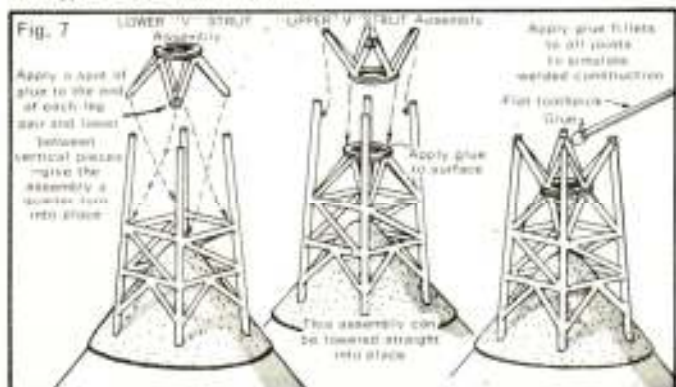

13. Apply a thin line of glue to the ring surface and a drop of glue to each leg joint of the upper "V" strut assembly. Slip this

15. Cut out the escape motor nozzle shrouds from the pattern sheet. Form each nozzle around the point of a 1/4" dowel or pencil sharpened with a standard (10¢ type) blade sharpener. (See fig. 9) The irregular inner edge of a shroud matches up to give the proper angled base to each shroud when glued to the tower tail cone base between each of the "V" struts.

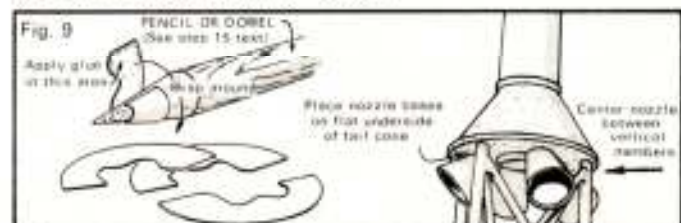

16. BE SURE TO FOLLOW THIS THREE-PART STEP IF YOUR MODEL IS TO BE FLOWN.

a) Apply glue to one edge of the adapter collar and center this collar on the base of the command module.
b) Insert the screw eye into the center of the base of the module. Remove the eye, squirt glue into the hole and replace the screw eye. Wipe off any excess glue from around the shaft.



c) Trace both patterns for the two-piece C/M to S/M umbilical into the BFS-40T and cut them out. Cut and sand to the shape shown for each piece. Apply glue to the back of the C/M half and attach to the command module, centered in the panel to the right of the positive pitch engines (which are directly below the hatch window) and with the bottom edge even with the command module skirt. The S/M half of the umbilical is to be used on the tube which is to receive the command module. Orient the command module as it is to ride on your model, then apply glue to the back of the S/M half and attach it to the tube so the upper edge is butt-joined (but not glued) to the bottom edge of the C/M half of the umbilical.

NOTE: This Apollo kit is also used in the Uprated Saturn I kit. In that application the Service Module half goes 1/2" to the right of the reaction control system engines which are located above the POS. III fin, with its top edge even with the top edge of the tube. Install this piece before painting the Saturn I.

17. Fig. 11 shows the details for the fully shrouded lift-off version (your option in step 3) and the positions of the external details in relation to the hatch window. Details and colors given for the tower/escape motor assembly are correct for either version.

