



**MODEL PRODUCTS**  
126 GROESBECK HIGHWAY  
MOUNT CLEMENS, MICHIGAN 48043

# VOSTOK

## RD-107 SPACE CARRIER ROCKET

MPC has reproduced the only authentic scale model of the RD-107 Space Carrier Rocket with Vostok or Sputnik Spacecraft options.

Your model may be built more than one way. You can build it as a static or flying model. Both versions assemble the same way until you get to the final assembly.

Use styrene cement on all plastic parts (unless otherwise noted) and use white glue on all paper parts (unless otherwise noted).

For removing small parts from the "runners," it is best to use a modelers knife; do not attempt to "twist" them off. Before joining parts, trim off any excess plastic or "flash." Scrape plating from chromed parts where they are to be joined with other parts. To join parts, use cement sparingly. Apply cement to very small parts with a toothpick.

You should have no trouble assembling your kit if instructions are followed properly. The parts are numbered in order of assembly.

### \* SPECIAL FLYING ROCKET NOTE

## SUB-ASSEMBLIES

**1.**

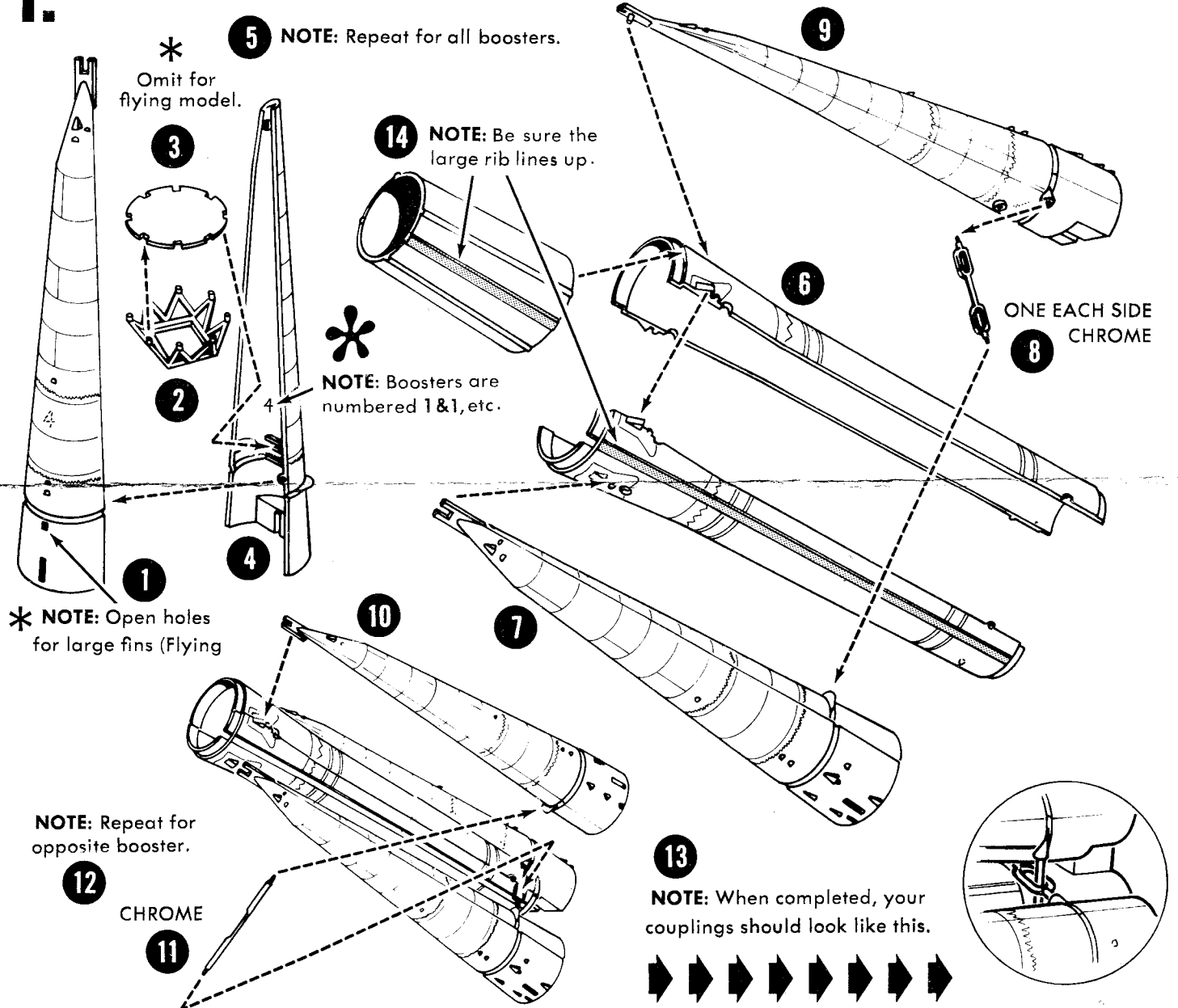

# 2.

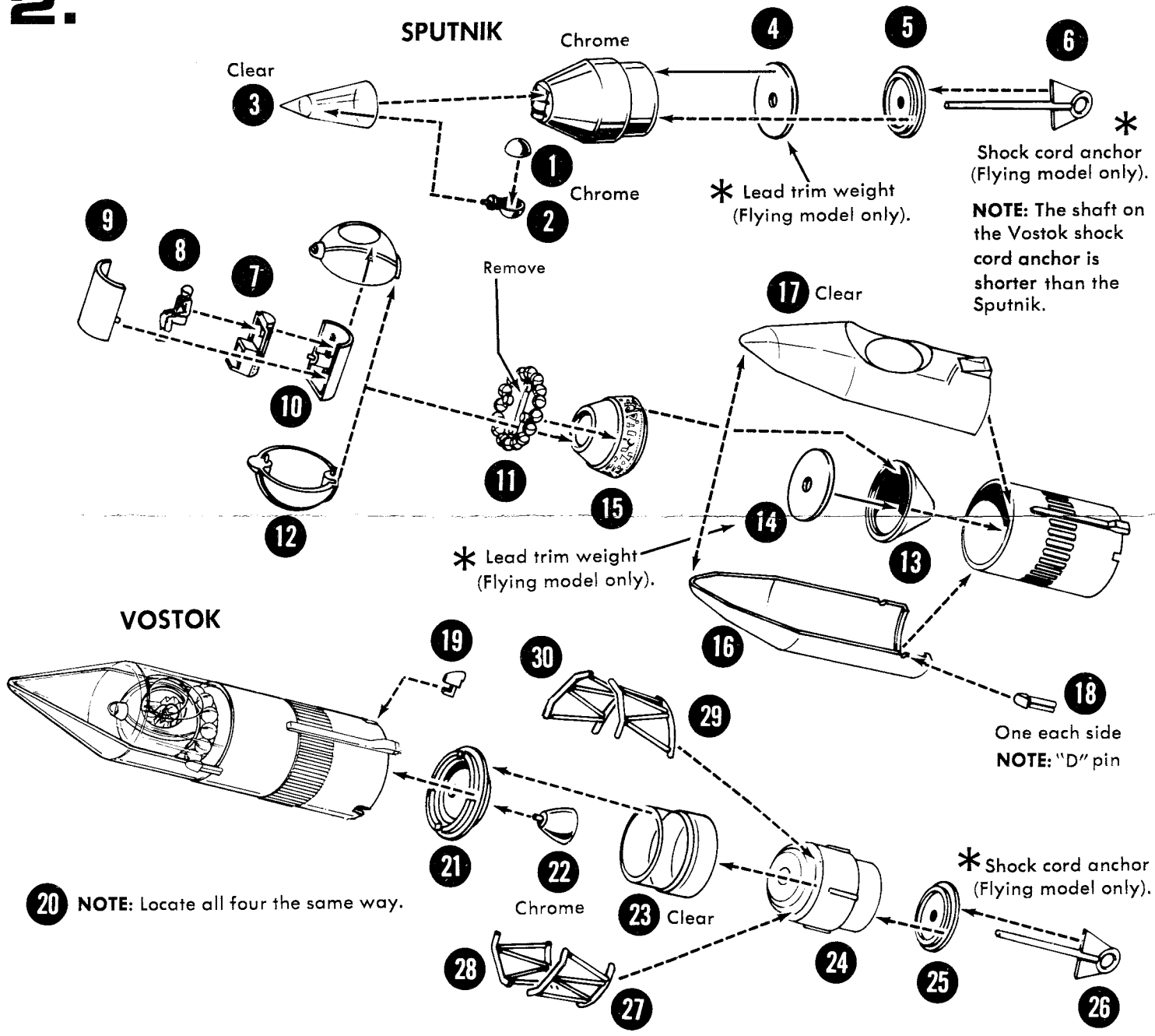

# 3.

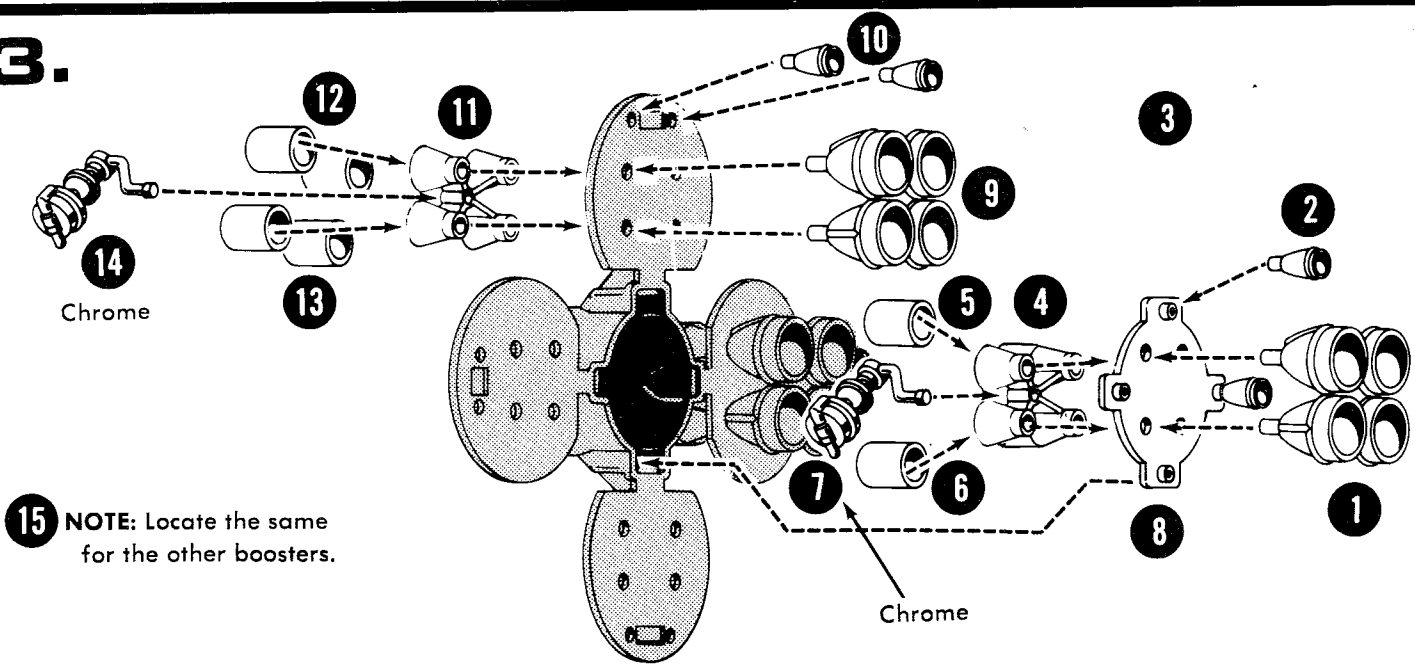

# FINAL ASSEMBLIES

NOTE: Small fins are for static model only.  
Locate all four the same way.

## STATIC MODEL

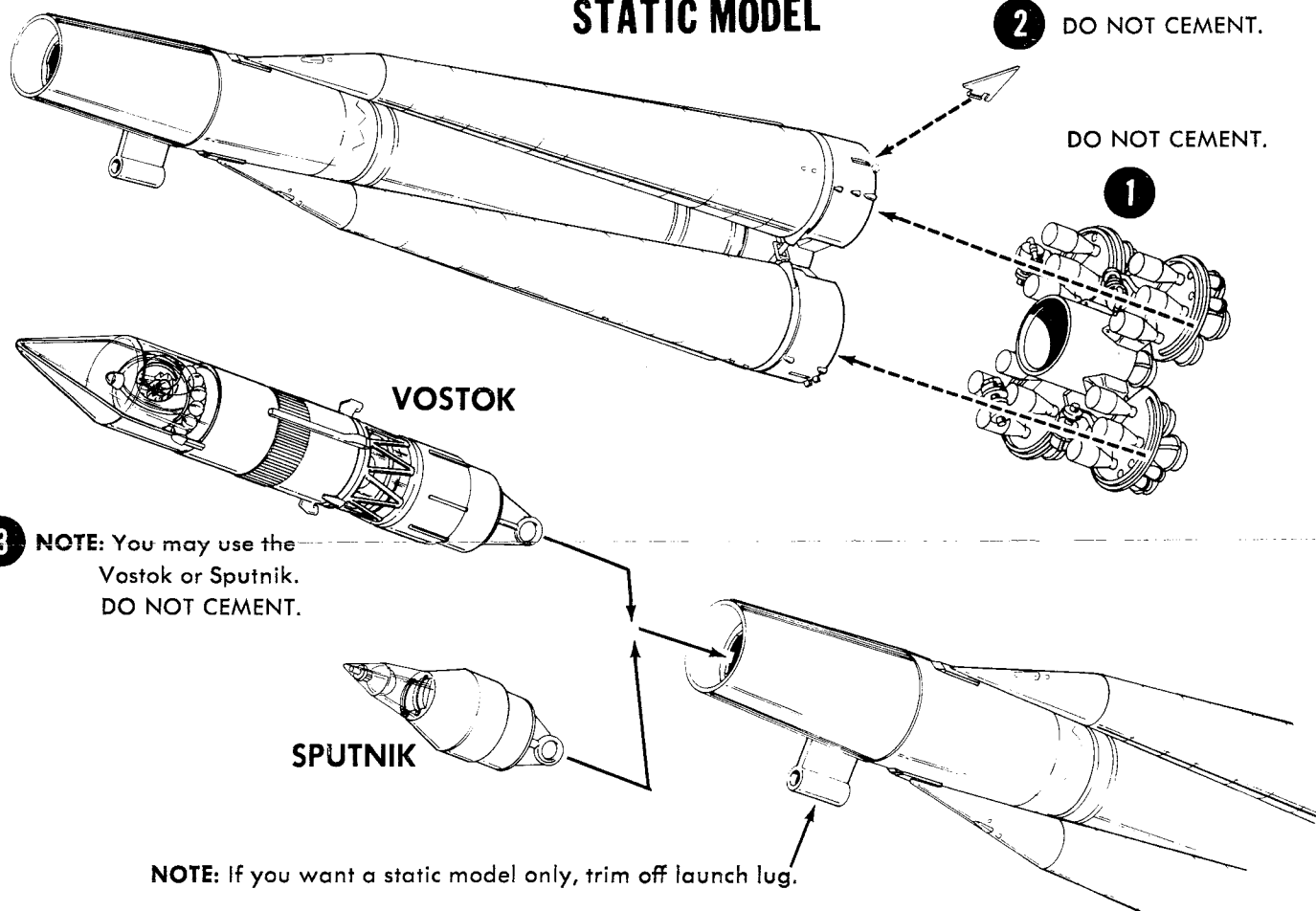

2 DO NOT CEMENT.

DO NOT CEMENT.

1

3 NOTE: You may use the Vostok or Sputnik.  
DO NOT CEMENT.

SPUTNIK

VOSTOK

NOTE: If you want a static model only, trim off launch lug.

## FLYING MODEL

# WARNING!

(MODEL ROCKET)

A flying model rocket is a scientifically designed educational model . . . NOT A TOY! If misused it can be dangerous. It is capable of attaining speeds up to 300 mph. It should be used only as instructed, and treated with care and respect. Adult supervision is recommended.

(MODEL ROCKET ENGINES)

Solid propellant Rocket Reaction Engines are specifically designed for the sole purpose of propelling model rocket vehicles. They are scientifically designed, produced on automatic machinery, and subjected to statistical quality control tests. It is very important, however, that caution be exercised in their use. All instructions must be read thoroughly first and followed completely. Model rocket engines are designed for one purpose only. They are not toys—and their mis-use must be absolutely avoided. Model rocketry has proven itself to be as safe as any other hobby when common sense codes are followed.

This model rocket has been designed and developed to give you a straight, high flight if the instructions are followed carefully. The exciting and educational sport of model rocketry has grown into a full scale national activity, and will continue to grow every time you fly your rocket safely. Formation of a rocket club in your area will provide you with hours of enjoyment, even when you're not launching rockets. Look for our new models appearing on your dealers shelves soon.

Before you begin building, look over the instructions carefully. Following the procedure given, test fit the parts without gluing. This way you will be more familiar with the location of parts when it becomes time to use glue. The parts list will acquaint you with the pieces in the kit.

- |   |
|---|
| RECOMMENDED TOOLS FOR<br>MODEL ROCKET BUILDING<br>Modeling knife<br>Extra strong white glue<br>Styrene cement<br>Ball point pen or pencil<br>Fine grit sandpaper<br>Paint in desired colors |
|---|

For a good flight, each and every time, use an MPC LUNAR LECTRIC LAUNCH PAD, and LAUNCH CONTROL to fly your model rocket.

## RECOMMENDED ENGINES

C9-3 OR C6-4.

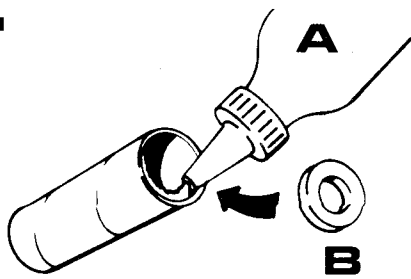
**1.**

Apply glue (white) around the inside edge of brown engine compartment tube (A). Insert engine block so that the ends are flush (B). Allow glue to dry. Sand the outside of the engine compartment until it fits into the 9-inch body tube (white paper) smoothly (C). Cut a small slit directly behind engine block  $\frac{1}{4}$ -inch from the end of the tube (D) and glue engine clip in place

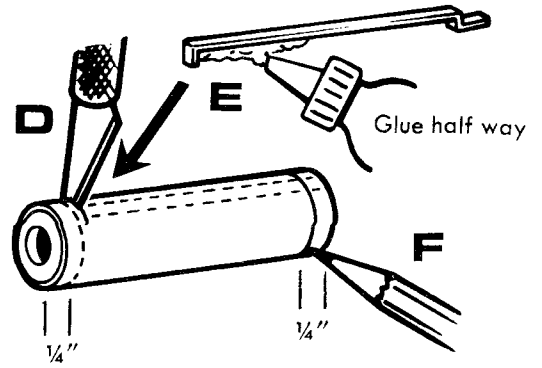
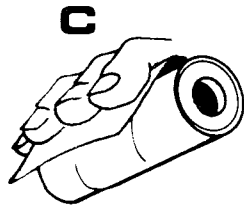

making sure it is straight as shown (E). On the opposite end from engine block, draw a line  $\frac{1}{4}$ -inch from the end (F). Insert the engine compartment (engine block first) (G) about half-way into 9-inch body tube, and place a ring of glue around it. With constant pressure against a table edge, push the engine compartment into the body tube until you reach the  $\frac{1}{4}$ -inch mark (H).

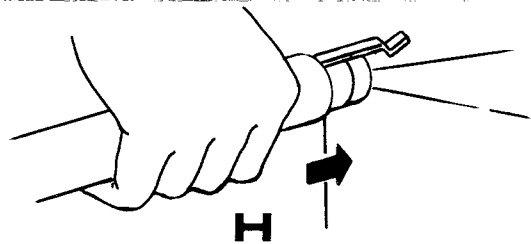
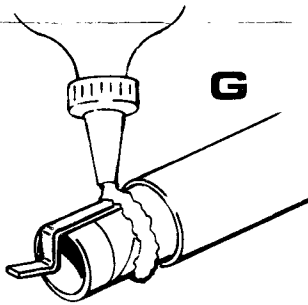
**2.**

On the opposite end of body tube, sand body tube lightly on the area where shock mount is to be attached (A). Thread shock cord through shock mount (B) and glue (white) to sanded area of body tube  $\frac{1}{2}$ -inch from end as shown. Insert body tube into main rocket (C) with shock cord protruding through the opposite end.

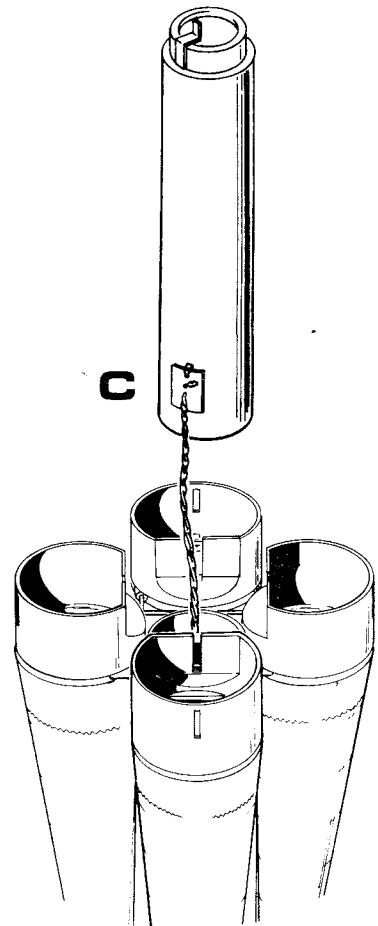
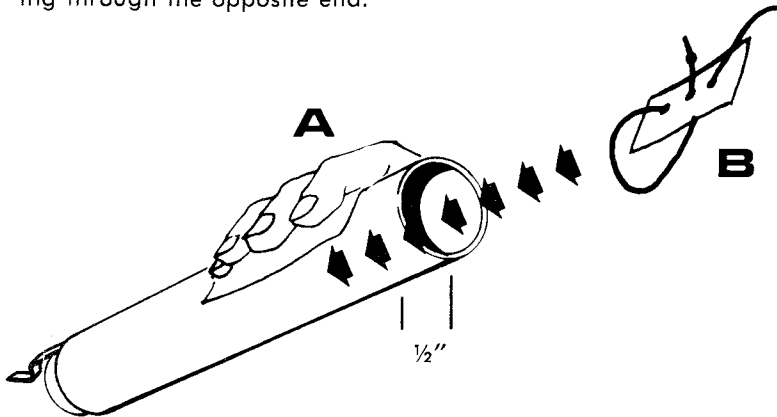

NOTE: You may use the Vostok or Sputnik.

3.

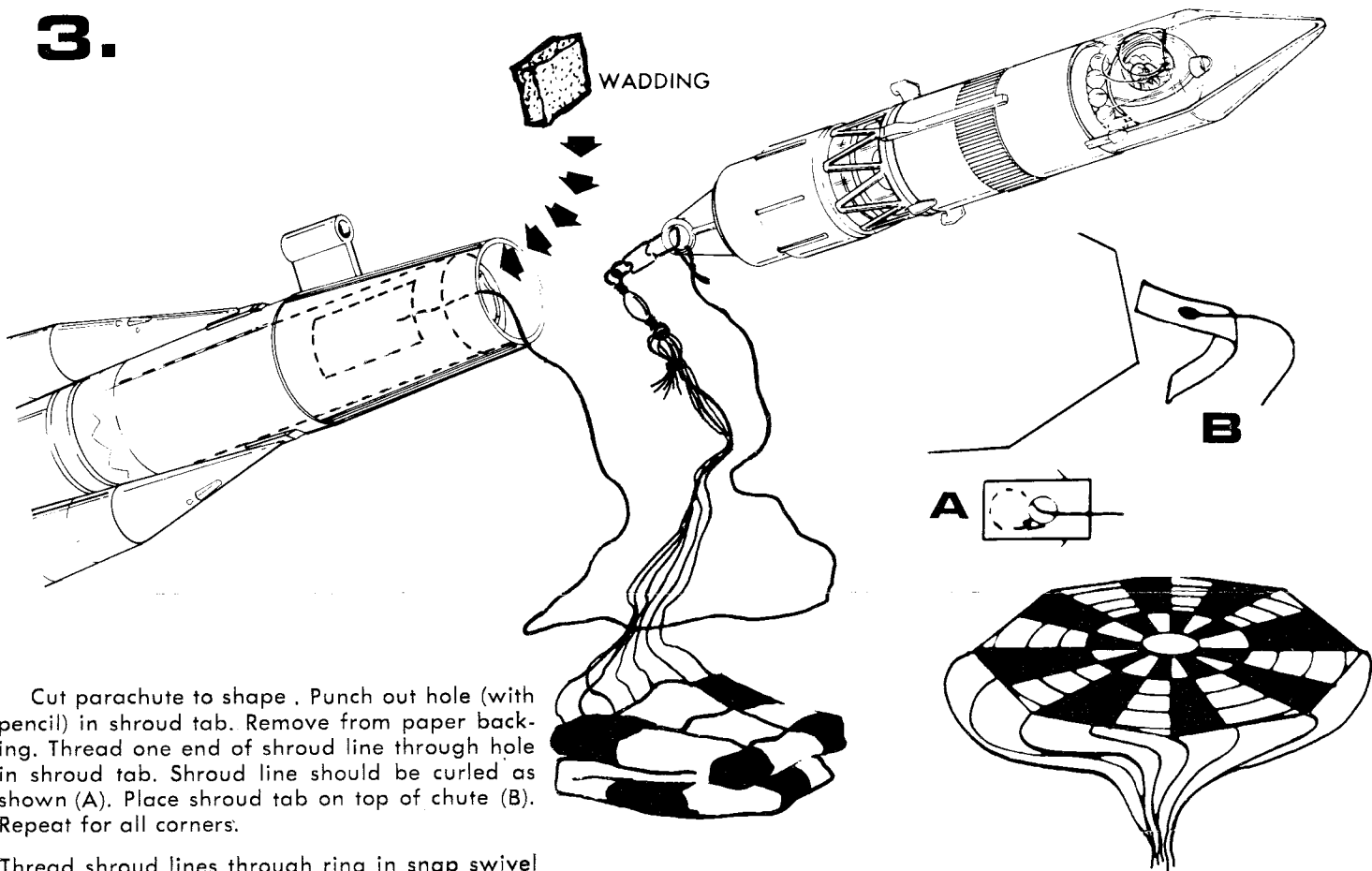

Cut parachute to shape. Punch out hole (with pencil) in shroud tab. Remove from paper backing. Thread one end of shroud line through hole in shroud tab. Shroud line should be curled as shown (A). Place shroud tab on top of chute (B). Repeat for all corners.

Thread shroud lines through ring in snap swivel and tie shock cord to shock cord anchor.

4.

Cement (styrene) the main thermal shield to main drive mount (A). Place (DO NOT CEMENT) main drive mount into position (B). Snap (DO NOT CEMENT) large fins into holes in boosters (C).

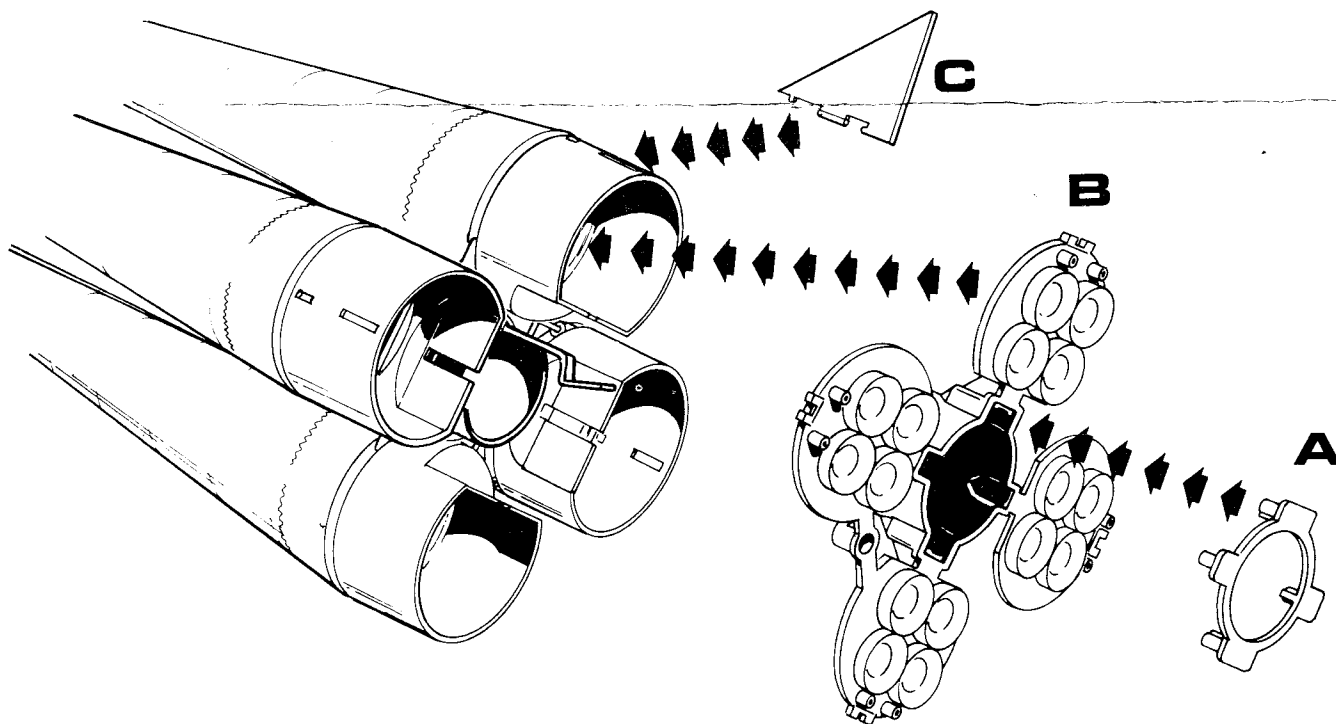

## A PAINTING

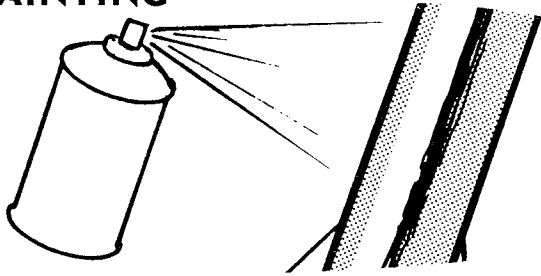

For best flight performance, and appearance, your rocket should have a smooth, hard finish. When painting, apply several light coats avoiding runs.

## B DECALS



To apply decals, cut them apart individually, cut close to design, then dip in water for a few minutes. Next slide decal off the paper backing as you apply it to your rocket, using the box cover as a guide in positioning. Before the decals dry, smooth out any bubbles with a damp cloth.

## C PARACHUTE

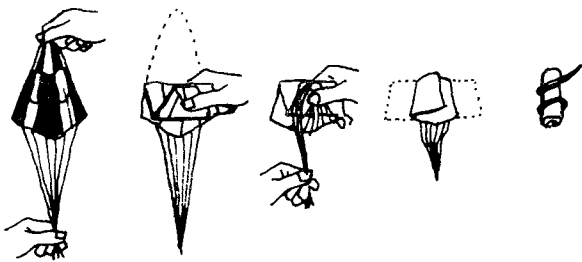

Pack flame-proof yellow fiberglass wadding (about 1 sq. inch) into top of body tube, pushing it down toward engine block (with a pencil). Fold parachute carefully into a cylinder as shown and wrap shroud lines around it. Insert parachute into body tube and pack shock cord on top of chute. Insert Vostok or Sputnik, whichever you prefer, into main rocket (DO NOT CEMENT).

## D LAUNCH INSTRUCTIONS

All model rockets must be launched electrically, using the MPC LUNAR-LECTRIC or similar launching system. Check with your hobby dealer.

**IMPORTANT:** All model rockets must be launched from a launch rod at least 36 inches long.

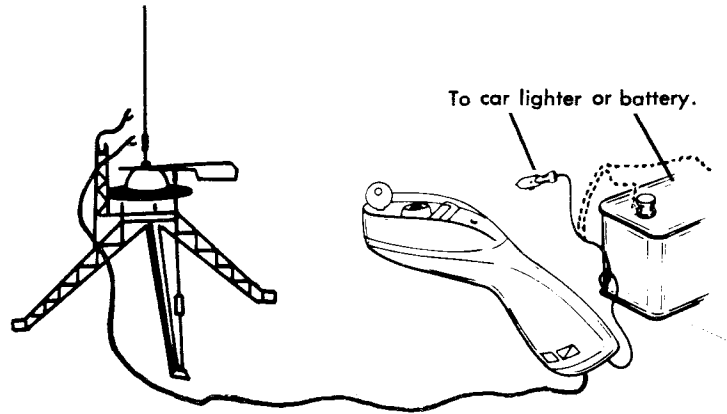

## E SELECTING A LAUNCH SITE

Choose a level area as your launch site. Clear the area under the launch pad of dry grass, and other flammable materials. Your launch site should be clear of trees, high buildings, power lines, and roads and freeways. An area 500' by 500' minimum is recommended for safe flight and recovery.

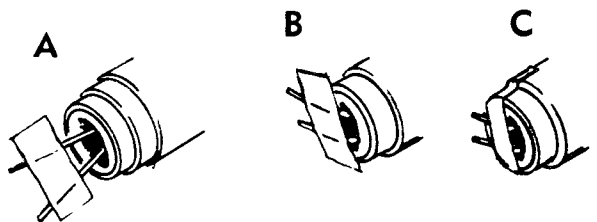

Before approaching launch pad, remove safety key from launch control handle, and disconnect leads from power source. Approach launch pad with model, engine and Ignitor. Peel paper backing from taped Ignitor and insert into nozzle of engine as far as it will go (A). Bend Ignitor over against engine (B). Press tape down onto engine to hold in place (C). Insert engine into engine compartment (with nozzle outward) until engine is locked in place with engine clip.

Lower rocket onto the launch rod by sliding the launch lug over rod. Attach one micro clip to each of the Ignitor leads extending from the engine. Retreat to launch control and give an audible warning to persons in the area that a countdown is about to begin. Connect leads to power source, insert safety key in the LUNAR-LECTRIC launch control, or whatever launch control you're using. Begin countdown procedure from countdown card, included in every MPC model rocket kit.

In the event that engines are not available in your area, take advantage of our three engine package by sending \$1.25 to MODEL PRODUCTS CORP., 126 Groesbeck, Mt. Clemens, Michigan 48043.

If you are a minor your order must be accompanied with a note from parent or guardian.

**For a good flight, each and every time, use an MPC LUNAR LECTRIC LAUNCH PAD, and LAUNCH CONTROL to fly your model rocket.**



**SOVIET RD-107  
SPACE CARRIER  
ROCKET**

# **ВОСТОК (VOSTOK)**

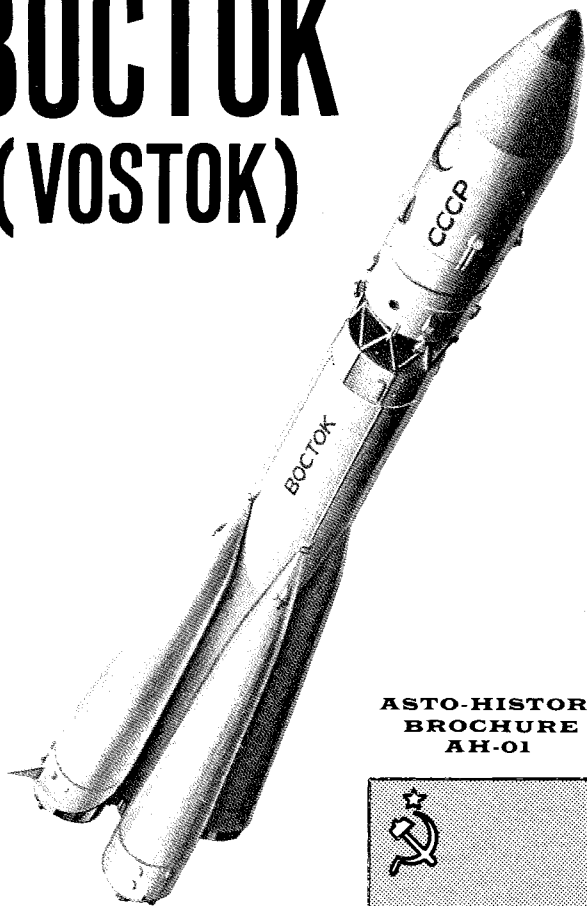

**ASTO-HISTORY  
BROCHURE  
AH-01**

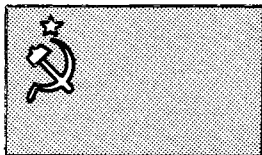

## SOVIET RD-107 SPACE CARRIER ROCKET

(Raketi-Nositeli)

The space program of the U.S.S.R. during the first decade of the Space Age was carried out primarily with the RD-107 Space Carrier Rocket designed by Sergei Pavlovich Korolev, "chief constructor" of the Soviet space agency. The RD-107 is a development of the Soviet SS-6 ICBM.

The first launchings of the SS-6 took place in the Soviet Union of 1957 and were tracked by U.S. long-range radar stations in Turkey. The launch site for these tests and all subsequent SS-6 and RD-107 missions is the Soviet "Cape Kennedy" base called Tyuratam near Baikonour northeast of the Aral Sea. On October 4, 1957 the Space Age began; an RD-107 launched Sputnik I into an orbit around the earth. This 1,324-pound sphere was separated from the 8000-pound core of the RD-107 which was also orbited.

The RD-107 by itself was limited to an orbital payload of about 3000 pounds until Korolev added the upper stage attached by trusses in 1960. This increased the orbital payload to about 10,400 pounds and enabled the RD-107 to launch unmanned probes with a payload of about 1400 pounds to Mars and Venus.

Following six unmanned orbital flights to test the unmanned Vostok spacecraft, Major Yuri A. Gagarin rode once around the world into history in Vostok I on April 12, 1961.

### OPERATION OF THE RD-107

To obtain the high thrust necessary for an ICBM, Korolev only brought together or "clustered" rocket combustion chambers to create the RD-107 rocket engine, but also brought together clusters of these clusters to produce a "parallel staged" rocket. The RD-107 takes off with all rocket engines operating, eliminating the then-difficult "air start" of upper stage rocket engines in flight.

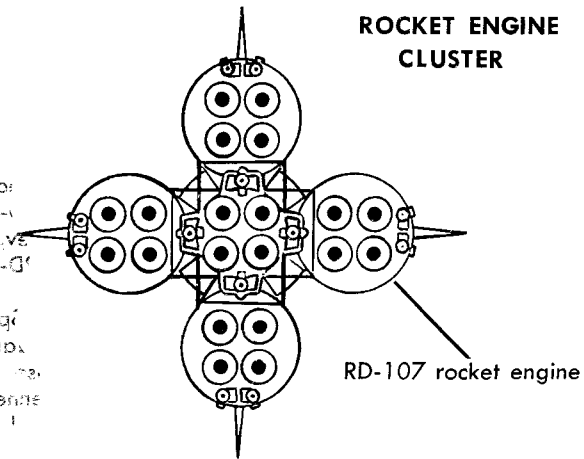

At launch, the RD-107 is supported by swing-back arms attached at the forward booster attach points. All 20 main thrust chambers and 12 vernier or steering thrust chambers are ignited at once. Estimated thrust at lift-off is 950,000 pounds, increasing to 1,150,000 pounds in flight.

At an altitude of approximately 185,000 feet some 130 seconds after lift-off, a velocity of 6600 feet-per-second (about 4500 miles per hour) is attained, and the rocket propellants in the booster tanks are exhausted. Explosive bolts sever the connections between the boosters and the core vehicle at the forward and aft booster attach points. The boosters fall away from the core. The core vehicle continues to be accelerated by its rocket engine until 332 seconds after lift-off.

The early Sputnik-version of the RD-107 had no second stage. Therefore, on the early flights until 1960, the entire 8000-pound core of the RD-107 was orbited with payloads up to 3000 pounds. When Korolev designed the upper stage, he powered it with the RD-119 rocket engine using liquid oxygen and unsymmetrical-dimethylhydrazine. The RD-119 is a re-startable engine that allows the second stage to enter a parking orbit for interplanetary or lunar shots, thus becoming what the Soviets term an "orbital platform" or "Nositel-Sputnik."



## VOSTOK

In earth orbit, the Vostok spacecraft remains attached to the RD-107 second stage which serves as an attitude control module. The Vostok spacecraft is made up of three modules: (a) a 96-inch diameter spherical command and re-entry module, (b) a service and retro-fire module ringed with air bottles, and (c) the RD-119 second stage which serves as an additional service module.

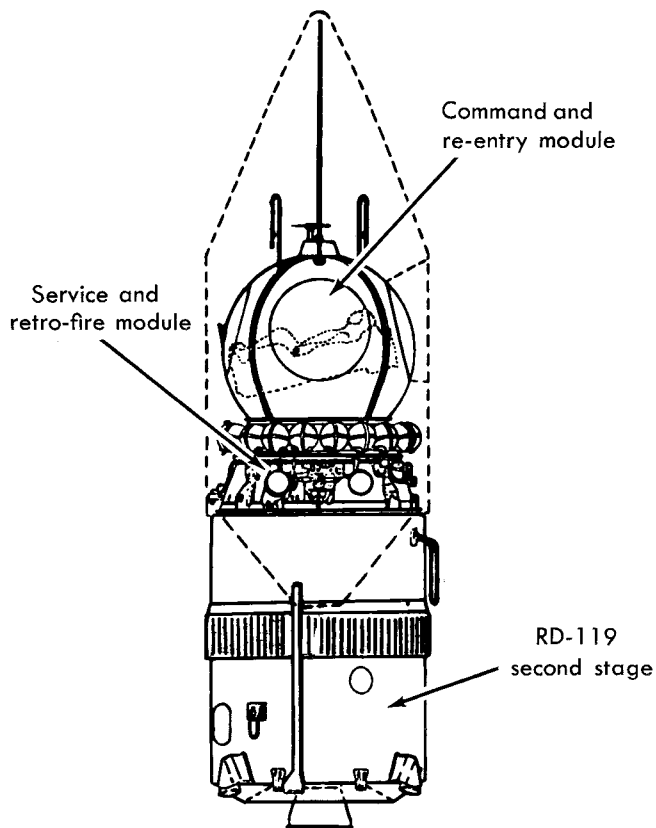

The entire Vostok spacecraft was an automatic unit capable of carrying out its orbital mission without the cosmonaut's attention. It was controlled by on-board or radio-link devices. However, the cosmonaut could take manual control of the spacecraft.

The re-entry sequence was normally completely automatic. First the second stage was jettisoned. Using sun and horizon sensors, the Vostok was positioned at the correct retro-fire angle. At the proper moment, the retro-fire engine was ignited, then the retro-fire module was separated, leaving only the 8-foot re-entry sphere. The re-entry sphere containing the cosmonaut was coated with a plastic-filled honeycomb material to act as an ablative heat-shield. Korolev chose the spherical shape for the re-entry module because the aerodynamic characteristics of a sphere were well-known.

At an altitude of 23,000 feet following re-entry, the cosmonaut hatch was blown off the sphere by explosive bolts, and the cosmonaut ejected from the sphere in a rocket-boosted ejection seat. He then separated from the seat and landed under his own personal parachute. The Vostok sphere deployed its parachute at 16,000 feet and landed. Major Gagarin landed inside his Vostok 1. All other Vostok pilots elected to land by the ejection method.

## SOVIET SPACE CARRIER ROCKET DATA

LENGTH OVERALL: 38 meters (124.678 feet)

DIAMETER OVER FINS: 10.3 meters (33.794 feet)

SUSTAINER LENGTH: 28 meters (91.868 feet)

MAXIMUM DIAMETER OF SUSTAINER: 2.95 meters (9.679 feet)

LENGTH OF BOOSTERS: 19 meters (62.339 feet)

MAXIMUM DIAMETER OF BOOSTERS: 3 meters (9.843 feet)

TOP STAGE LENGTH OVER NOSE FAIRING: 10 meters (32.81 feet)

MAXIMUM DIAMETER, TOP STAGE: 2.58 meters (8.465 feet)

NOMINAL VOSTOK WEIGHT, INCLUDING PILOT: 4725 Kilograms (10,400 pounds)

TOTAL THRUST, LIFTOFF: 950,000 pounds.

TOTAL THRUST, VACUUM: 1,150,000 pounds.

### ESTIMATED WEIGHTS:

Propellants in 4 boosters: .....	375,000 lb.
Propellants in sustainer: .....	240,000 lb.
Propellants in top stage: .....	32,000 lb.
Total Propellants: .....	647,000 lb.
Vostok spacecraft: .....	10,400 lb.
Empty vehicle: .....	61,400 lb.
Total empty weight: .....	71,800 lb.
Lift-off weight: .....	718,800 lb.

LIFT-OFF ACCELERATION: 1.3 g's

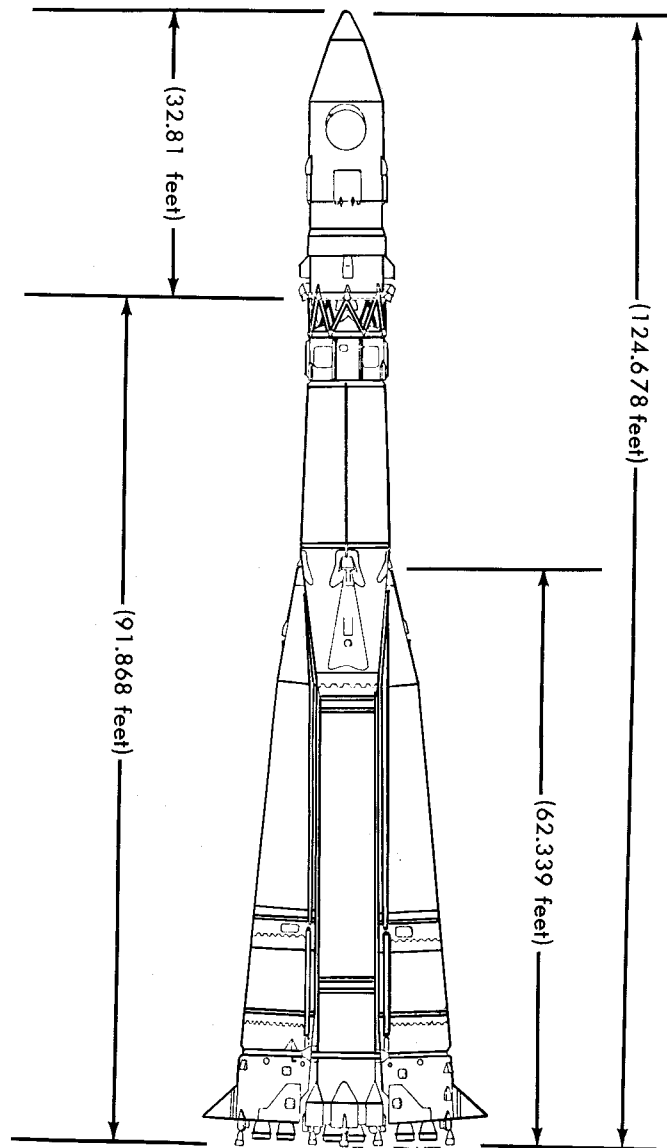

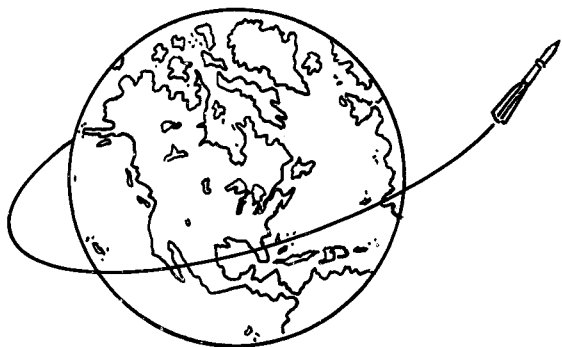

### SOVIET RD 107 ROCKET ENGINE DATA

**TYPE:** Liquid-propellant, multi-chamber, turbo-pump fed.

**THRUST IN VACUUM:** 102 t (228,480 pounds).

**VACUUM SPECIFIC IMPULSE:** 314 sec.

**CHAMBER PRESSURE:** 60 atmospheres (885 pounds per square inch).

**PROPELLANTS:** Liquid oxygen and hydrocarbon.

**CONFIGURATION:** Four main thrust chambers, regeneratively-cooled, and two or four vernier chambers, regeneratively-cooled, supplied with propellants by single turbo-pump.

**TURBO-PUMP DETAILS:** Single-shaft. Double-sided LOX pump. Single-sided fuel pump. Centrifugal type. Driven by gas generator which in turn is fed by smaller centrifugal pump. Gas generator apparently driven by decomposition of hydrogen peroxide.

**INJECTOR DESIGN:** Single-plate injector in each chamber. Welded construction.

**THRUST CHAMBER MATERIALS:** External walls apparently steel. Internal chamber walls of high copper alloy.

### SOVIET SPACE CARRIER ROCKET FLIGHT HISTORY (Unmanned Program)

**AUGUST 30, 1957:** Department of Defense (U.S.) announced 4 to 6 Soviet ICBM tests during Spring 1957.

**OCTOBER 4, 1957:** Orbiting Sputnik-I, 184 pounds of instruments. 8000 pounds in orbit. 142 x 588 miles, 65° inclination. Down January 4, 1958. *First man made Satellite.*

**NOVEMBER 3, 1957:** Orbiting Sputnik-II, 1,120 pounds. 8000 pounds in orbit. 140 x 1038 miles. 65° inclination. Down April 4, 1958. *First Astro Biological flight with dog "Laika."*

**MAY 15, 1958:** Sputnik-III in orbit, 2925 pounds. 7000 pounds orbited. 135 x 1167 miles. 65.3° inclination. Down May 6, 1960.

**JANUARY 2, 1959:** Launched Lunik-I into solar orbit. 3245-pound capsule, 800 pounds of instrumentation.

**SEPTEMBER 12, 1959:** Launched Lunik-II to lunar impact. 858.4 pounds of instruments on moon.

**OCTOBER 4, 1959:** Launched Lunik-III to lunar orbit for photography of backside of Moon. 614-pound spacecraft. 3423-pound empty stage with 345 pounds of instruments aboard.

**FEBRUARY 12, 1961:** Sputnik-V orbited. 1419-pound Venus probe into 115 x 155 mile parking orbit.

**SEPTEMBER 1, 1962:** Orbiting Venus-I failed in parking orbit.

**NOVEMBER 1, 1962:** Orbiting Mars-I, 1980 pounds.

**JANUARY 4, 1963:** Orbiting 3080-pound un-named spacecraft which failed in parking orbit.

**APRIL 2, 1963:** Launched Luna-4, 3136-pound soft-lander, failed.

**MARCH 12, 1964:** Launched Kosmos-60, 3200-pound lunar soft lander, failed in parking orbit.

**MAY 9, 1965:** Launched Luna-5, 3255 pounds, impacted on Moon.

**JUNE 8, 1965:** Launched Luna-6, 3180 pounds, missed lunar impact.

**JUNE 18, 1965:** Launched Zond-3, 2000-pounds, lunar photographic orbiter, 25 photos of lunar farside.

**OCTOBER 4, 1965:** Launched Luna-7, 3321 pounds, impact on Moon.

**DECEMBER 3, 1965:** Launched Luna-8, 3422 pounds, impact on Moon.

JANUARY 31, 1966: Launched Luna-9, 3491 pounds, soft-landed on Moon. 27 photos returned.

MARCH 1, 1966: Launched Kosmos-III, 3500 pounds, lunar shot failed in parking orbit.

MARCH 31, 1966: Launched Luna-10, 3588 pounds, orbited Moon.

AUGUST 24, 1966: Launched Luna-11, 3616 pounds, orbited Moon.

OCTOBER 22, 1966: Launched Luna-12, 3600 pounds, returned photos from lunar orbit.

DECEMBER 21, 1966: Launched Luna-13, 3600 pounds, soft landed on Moon, returned photos.

### MANNED PROGRAM

MAY 15, 1960: Launched Spacecraft-I, 10,008 pounds. Recovery failed. Still in orbit.

AUGUST 19, 1960: Launched Spacecraft-II, 10,120 pounds, 2 dogs, rats, mice, flies, plants, seeds, fungus, etc. 190 x 211 miles. 64.57° inclination. Recovered 7 miles from target on August 20, 1960.

DECEMBER 1, 1960: Launched Spacecraft-III, 10,060 lb. Vostok, 117 x 165 miles, 65° inclination. Recovered December 2, 1960.

FEBRUARY 4, 1961: Orbited Sputnik-IV, 14,292-pound Vostok, 138 x 203 miles, 64° inclination. Down February 26, 1961.

MARCH 9, 1961: Orbited Spacecraft-IV, 10,340-pound Vostok with dog. 115 x 155 miles. Recovered March 9, 1961.

MARCH 25, 1961: Orbited Spacecraft-V, 10,300-pound Vostok, 111 x 150 miles, 65° inclination with dog aboard. Recovered.

APRIL 12, 1961: Orbited Vostok 1 with Major Yuri Gagarin aboard. 108 x 187 miles. 65° inclination. Recovered after 1 orbit. *First manned orbital flight.*

AUGUST 6, 1961: Orbited Vostok 2 with Major German Titov aboard. 110 x 115 miles. 65° inclination. Recovered after 17 orbits.

AUGUST 11, 1962: Orbited Vostok 3 with Nikolayev aboard. 105 x 156 miles. 65° inclination. Recovered after 64 orbits.

AUGUST 12, 1962: Orbited Vostok 4 with Popovich aboard. 111 x 158 miles. 65° inclination. Recovered after 48 orbits.

JUNE 14, 1963: Orbited Vostok 5 with Bykovskiy aboard.

JUNE 16, 1963: Orbited Vostok 6 with Valentina Treshkova aboard.

### SOVIET COSMONAUTICS TERMS

CARRIER ROCKET—Raketi-Nositeli

SATELLITE—Sputnik

CARRIER SATELLITE—Nositel-Sputnik

SPACESHIP—Korabl

MANNED SPACESHIP SATELLITE—Chelovek Korabl Sputnik

### A NOTE FROM MPC

Model Products is proud to present a world's first authentic scale model of the RD-107 Space Carrier Rocket and the Vostok Spacecraft.

Much research and time consuming labor went into the reproducing of the Soviet Union's most celebrated Space Vehicle.

The making of a rocket kit was a new challenge to MPC, long a leader in model car kits, and we feel it will open a whole new horizon for you the Model Builder.

Look for our great companion kit, The Pilgrim Observer. A brand new concept in what the space station of the "not too distant" future will look like.

For the flying rocket fan, MPC has a whole new line of flying model rockets, plus launch pad and hand control.

If it's the latest in space age ideas and flawless realism you're looking for, look no further than MPC . . . The one word in Model Kits.





1. Mission pin for Vostok I with Major Yuri A. Gagarin in man's first orbital flight.



2. Mission pin for Vostok 3 & 4 in 1962.

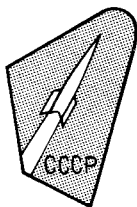

3. This pin is the Soviet equivalent to the NASA seal.

### SOVIET COUNTDOWN

- 5—"pyah"
- 4—"chetee-reh"
- 3—"tree"
- 2—"dvah"
- 1—"ohdeen"
- START—"start"

**MODEL PRODUCTS**  
126 GROESBECK HIGHWAY  
MOUNT CLEMENS, MICHIGAN 48043