

# KAPPA ONE

SPORT ROCKET



Length:  
18 inches

PARACHUTE  
RECOVERY

PAYLOAD  
SECTION



## INSTRUCTIONS

- 1 There are two sections of body tube in the KAPPA ONE, the main body tube nine inches (225 mm) long and the six inch (150 mm) payload section. Cement balsa adapter into one end of payload compartment allowing one half of adapter to project from end of tube. Turn the screw eye into center of adapter. Remove screw eye and apply cement in and around the hole. Replace screw eye and allow to dry.
- 2 Place nose cone into open end of payload section. Nose cone should fit tight in tube. If it is loose, a proper fit may be obtained by wrapping the base lightly with tape.
- 3 Measure down one inch (25 mm) from end of body tube. Cut a slit crosswise slightly over one quarter inch (6 mm) in length. Cut a second slit about one half inch (12 mm) directly below the first one. Push end of shock cord down through bottom slit. Reach inside with tweezers and pull the cord through until about one inch (25 mm) of shock cord is left outside of body tube. Tuck short end of cord down into front slit. Apply glue under loop of shock cord on outside of body. Pull long end of shock cord until loop lies flat against body. Coat with glue.
- 4 Thread loose end of shock cord through screw eye and secure with several overhand knots.
- 5 Apply a liberal ring of glue inside aft end of body tube and insert engine block. Using the engine compartment as a plunger and a guide, push engine block forward with compartment until compartment is flush with end of body tube. Back compartment halfway out, apply glue to its surface and return to original position.
- 6 Sand outer surface of body tube lightly to prepare it for finishing. Cut out fins from fin pattern sheet and sand leading and trailing edges. Do not sand the root edge (that part of the fin which is to be glued to body tube). Wrap fin spacing guide around aft end of body tube and mark the tube at points indicated on the guide. Connect upper and lower marks. These parallel lines are used to position fins. Glue fins along these lines making sure each fin is parallel to the body tube and projecting straight away from it. Allow to dry and apply fillets along both sides of each fin.
- 7 Glue launching lug about halfway up the body tube so that it is not in line with any of the fins. The lug must lie parallel to body tube. For additional strength, add a fillet of glue along each side of lug.
- 8 Sand outer surface of nose cone and body tube lightly with emery cloth. Repeat until a smooth finish is obtained. Use any color or combination of colors to finish your model. For easier tracking, we suggest that you use colors which will be most visible against the sky.

### ADDITIONAL NOTES      Recovery Wadding

The recovery wadding is necessary to protect your recovery devices from hot engine gases during ejection. Wadding must be placed in the body tube and pushed down until it comes in contact with the engine block.

## RECOMMENDED MOTORS: A3-2, B3-3

FIG. A

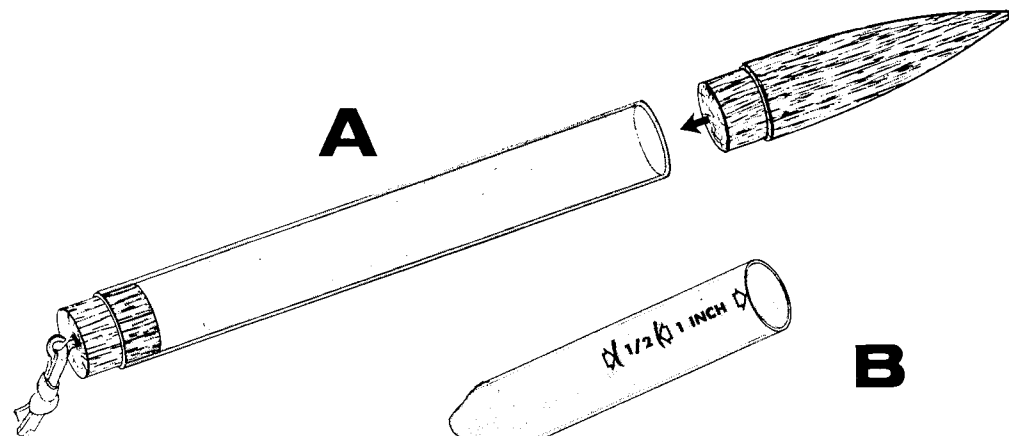

FIG. B



FIG. C

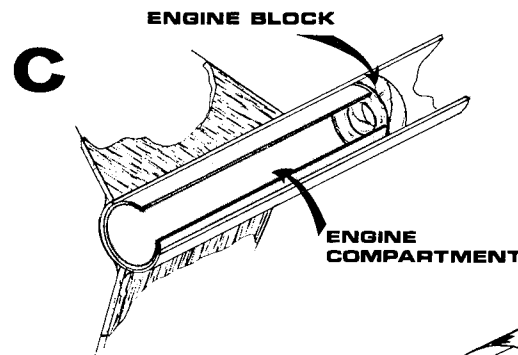

FIG. D

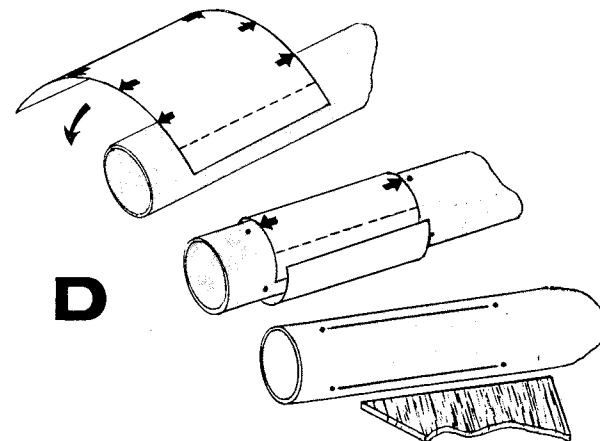

FIG. E

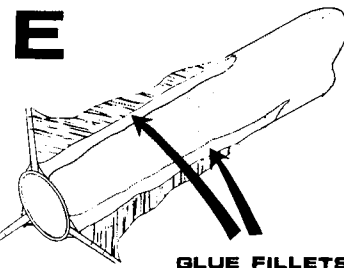
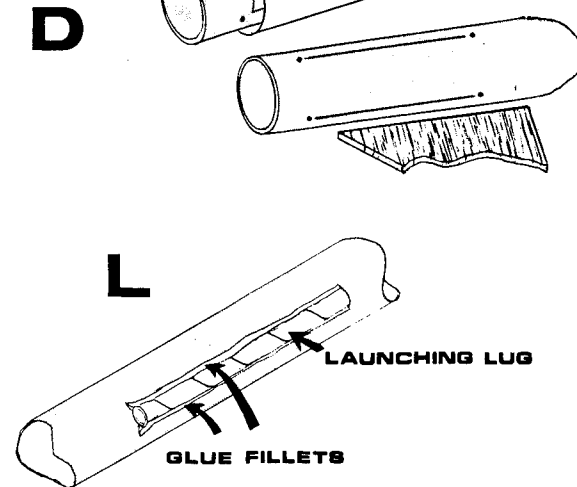

FIG. L



# PARACHUTE INSTRUCTIONS

Lay the parachute out face down on a flat surface. Cut off excess plastic outside of octagonal border. Attach one shroud line to each of the eight corners of chute by pressing a tape disc over a loop of shroud line and onto oval guide at each corner of chute. (See illustration).

Gather free ends of shroud lines and tie them together with the knot about 50 mm (two inches) from end. Thread four of the lines through eye in snap swivel. Now tie all eight lines together with a square knot to secure snap swivel. Attach snap swivel to screw eye in adapter. Place about one square inch of recovery wadding in body tube and push until it comes in contact with the engine block.

Hold parachute in the center allowing rocket to hang free. Collapse the chute so it resembles a folded umbrella (see Figure P). Fold collapsed parachute into thirds and place it in parachute compartment. Lay shroud lines and shock cord loosely on top of chute and join payload section to the lower body tube. Your model rocket is now ready for launching.

HINT . . . . . Sprinkle talcum powder over chute before collapsing and folding it. This will keep plastic surfaces from adhering to each other when packed in tube.

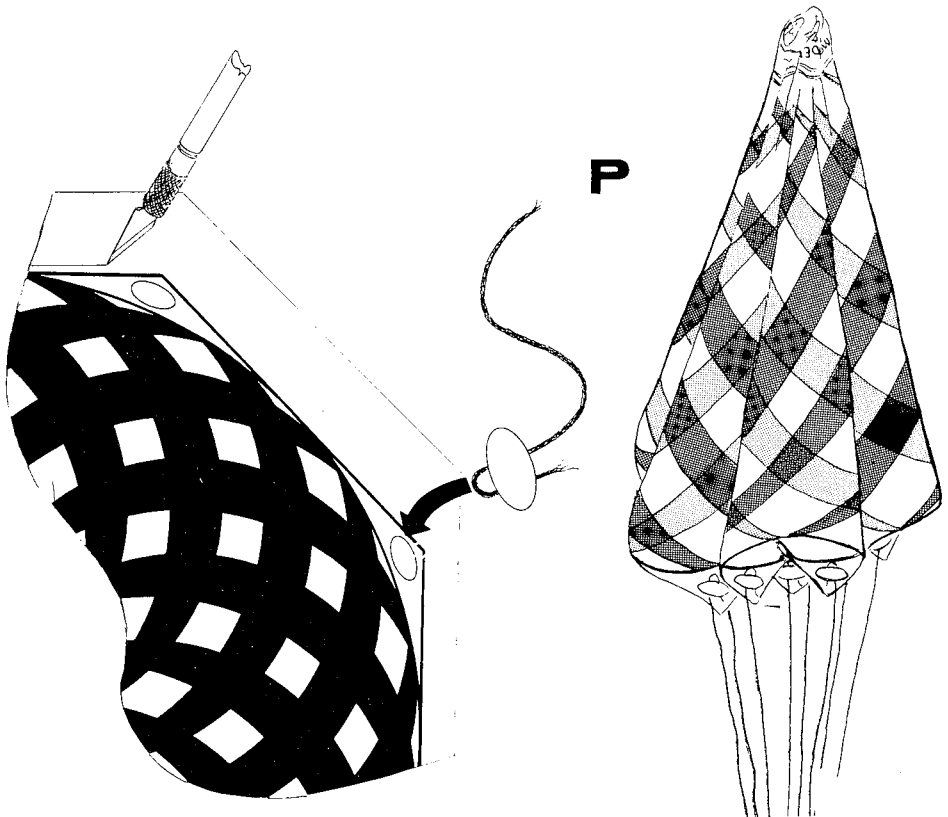

## PREPARING YOUR ROCKET FOR LAUNCHING . . . . .

Take your assembled kit and place wadding and the recovery system into recovery compartment. Insert the nose cone or adapter of the upper section into main body tube. The joining section must fit loosely enough in the main tube to allow proper functioning of the recovery device upon activation of the ejection charge. Insert engine in aft end of body tube and check fit. The engine must be tight to prevent it from blowing out when the ejection charge pressurizes the tube. If it is loose, a tighter fit may be obtained by laying a strip of tape along one or both sides of the engine.

After the engine has been properly fitted into the model take a two inch (50 mm) piece of nichrome wire and bend it in half. Insert the V into the orifice of engine. (DO NOT POINT ORIFICE TOWARDS FACE.) Apply a small wad of paper between the leads to act as an insulator and retainer. Tamp in position with the lead of a pencil.

Lower the model onto the launching rod by means of the launching lug.

**CHECK** that the power is off in your ignition system and attach micro-clips to the nichrome leads.

### \*Suitable Ignition Circuit

#### Recommended Batteries

BURGESS	TW 1
EVEREADY	731
RAY-O-VAC	918

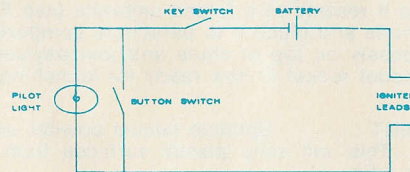

### OPERATION . . .

With the key switch in the off position, the igniter leads are fastened to the igniter. The key switch is turned to the on position and the battery forces the current to flow through the pilot light. The glow of the light indicates the circuit is prepared for the final phase of the launching procedure. During your count down, press the button switch . . . the pilot light goes off as the current passes through the igniter, and the engine fires. Turn the key switch to the off position.

Retreat 15 or 20 feet from the rocket and launching pad with your control panel and give an audible warning to persons in the area.

Make a last minute check that all is in order and that you are complying with the NAR safety code. . . . Begin your count down and launch on zero.

**IF THE ENGINE FAILS TO IGNITE . . .** Turn the key switch off and wait one minute. Approach the launching pad and disconnect the leads. Have the adult supervisor check to ascertain the problem.

### FOLLOW THE NATIONAL ASSOCIATION OF ROCKETRY SAFETY CODE:

1. I will obey the laws regarding rockets.
2. I will not mix my own rocket propellants or delay trains, etc.
3. I will not make my own rocket engines. I will use pre-loaded, factory-made commercial model rocket engines that do not require mixing the propellant.
4. I will treat all rocket engines with care, keeping them from heat and not dropping them.
5. My model rockets will contain no substantial metal parts.
6. My model rockets will contain a recovery device to return them safely to the ground so that they may be flown again.
7. My model rockets will not contain explosive war heads.
8. I will fly model rockets with adult supervision in proper areas away from houses, buildings, trees and power lines.
9. I will use a remotely-operated electrical firing system to ignite model rocket engines, and I will not install the electrical ignition element in a rocket engine until shortly before launching.
10. I will always use a launching device that is pointed within thirty degrees of the vertical.
11. I will not fly model rockets against targets in the air or on the ground.
12. I will not fly model rockets in windy weather or in conditions of low visibility.
13. I will not fly model rockets where they may endanger aircraft in flight.
14. I will always act in a mature manner with safety uppermost in mind.
15. I will not engage in any operation that may endanger myself or others.

# KAPPA ONE SPORT ROCKET

See inside for instructions.

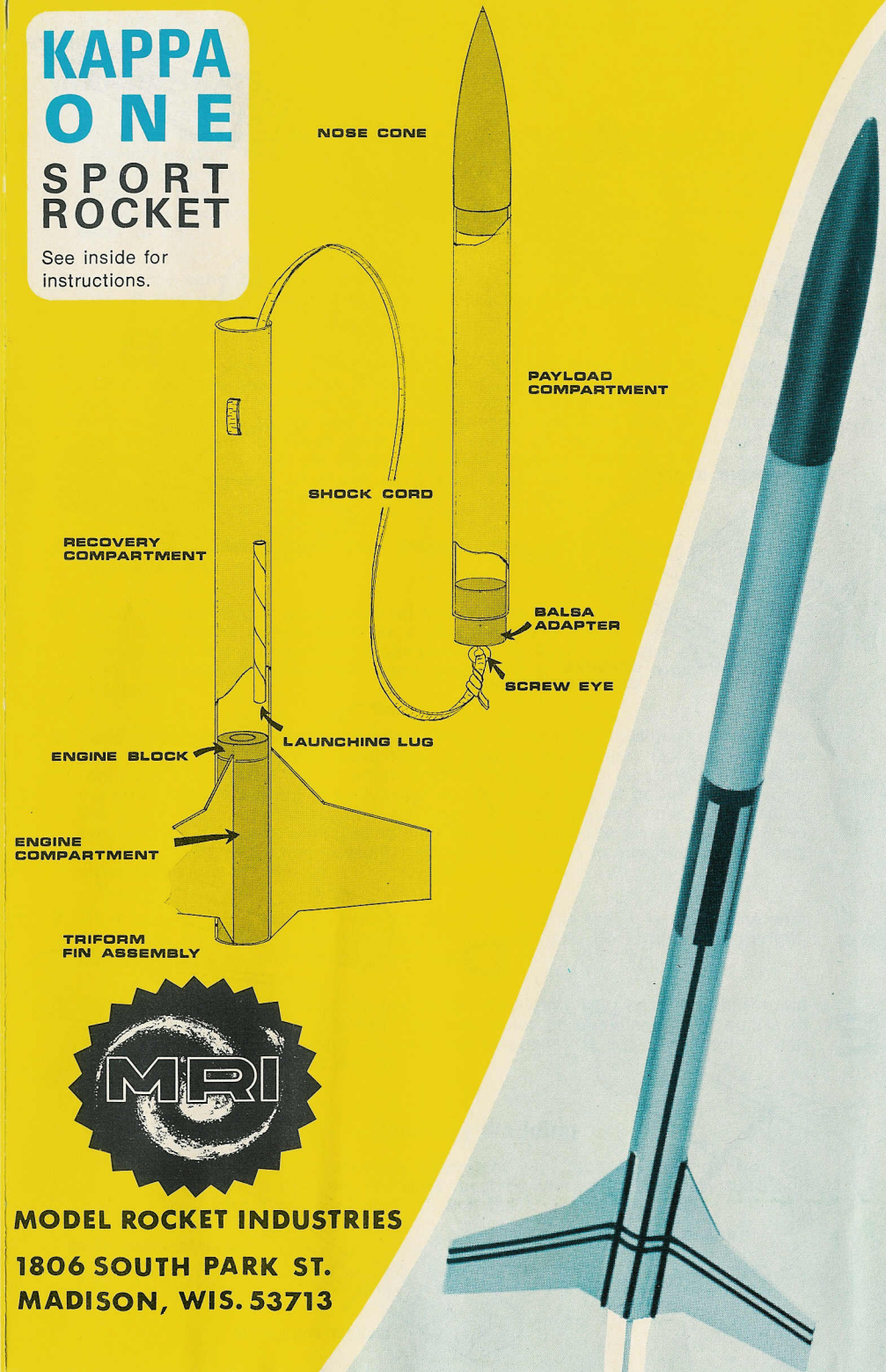

**MODEL ROCKET INDUSTRIES**  
**1806 SOUTH PARK ST.**  
**MADISON, WIS. 53713**

MODEL ROCKET INDUSTRIES, 309 STATE STREET, MADISON, WISCONSIN 53703

MRI Model Rockets are sold  
exclusively thru Hobby Stores.  
Insist on MRI replacement parts.

**MRI**

206:210

**\$2.10**

**MODEL  
ROCKET  
KIT**

# MRI Kappa 1

## Sport Rocket

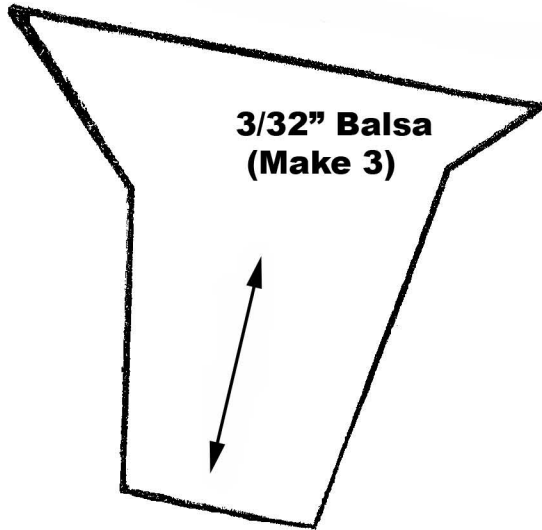

**Main Body Tube:** 20 mm x 9.0 in  
**Payload Tube:** 20 mm x 6 in  
**Motor Tube:** 18 mm x 2.5 in  
**Nose Cone (balsa):** 3.125 in

