

# FK-3

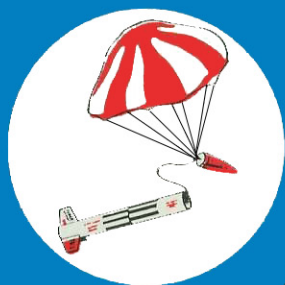

**CANAROC** 

## FLYING SPACE MODEL KIT TROUSSE MODELE SPATIAL VOLANT

ENGINES NOT INCLUDED - ENGINES NON INCLUS

SKILL LEVEL NIVEAU DE COMPETENCE

BEGINNER	NOVICE	INTERMEDIATE	ADVANCED	EXPERT
1	2	3	4	5
COMMENCANT	NOVICE	INTERMEDIAIRE	AVANCE	SPECIALISTE

### SPECS

LENGTH / LONGUEUR 31.5 cm (12.5")  
DIAMETER / DIAMETRE 2.5 cm (.98")

### RECOMMENDED ENGINES ENGINES RECOMANDES

A2-4 B2-4 C6-7  
A8-3 B4-4 C6-6  
B6-4

MANUFACTURED IN CANADA BY  
FABRIQUE AU CANADA PAR

CANAROC INDUSTRIES LTD  
BOX 3275, EDMONTON, ALBERTA T5L 4J1

#MK-15

# FK-3

## ASSEMBLY INSTRUCTIONS

READ THESE INSTRUCTIONS CAREFULLY  
BEFORE YOU START BUILDING

Additional materials and tools  
required for construction:

- modelling knife or  
single edge razor blade
- fine sandpaper
- butyrate dope
- cornstarch or talc
- white glue
- sanding block
- paint
- scissors
- ruler
- masking tape

Additional items required to  
fly the FK-3 are:

- Heat Wadding
- Trans-A-Pad Launcher
- Countdown Controller
- Canaroc Engines
- Masking Tape

### PARTS LIST

- |                                  |                    |
|----------------------------------|--------------------|
| A) 1 - PT-200 Body Tube (22.9cm) | H) 8 - Tape Disks  |
| B) 1 - ET-100 Engine Tube        | J) 1 - Shock Cord  |
| C) 2 - Centering Rings           | K) 1 - Launch Lug  |
| D) 1 - Engine Retainer           | L) 1 - Balsa Sheet |
| E) 1 - BN-200C Nose Cone         | M) 1 - Decal Sheet |
| F) 1 - Parachute (30 cm)         | (not shown)        |
| G) 1 - Shroud Line               |                    |

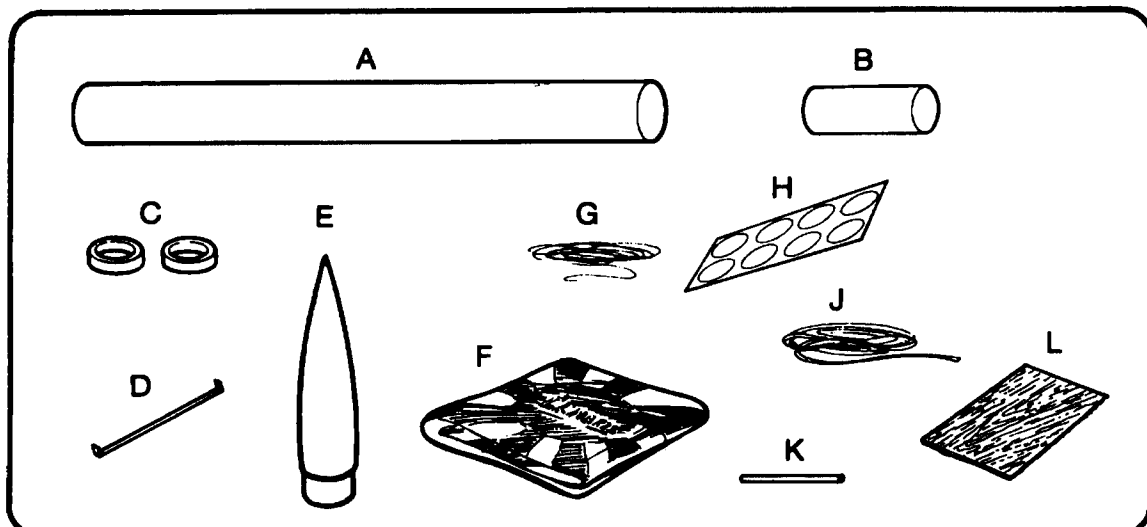

## CONSTRUCTING THE FINS

A Cut out the fin pattern from the pattern sheet.

B Trace the pattern onto the balsa fin sheet using the fin layout shown (Fig. 7). Be very careful that the balsa grain direction is as shown on the pattern.

C Carefully cut out each fin from the balsa using a modelling knife or single edge razor blade. **DO NOT ATTEMPT TO CUT THE Balsa IN A SINGLE STROKE.** When cutting balsa, run the blade lightly along the line to be cut barely applying pressure on the first stroke. On each stroke afterward, apply more force on the blade. After three or four strokes, the balsa will have a smooth clean cut. Attempting to apply too much force and making the cut in one stroke will easily tear the balsa, giving the fin an unsightly appearance.

D To improve the appearance of the fins, round the leading edge and trailing edge of the fins (as shown in Fig. 8) by gently sanding with fine sandpaper or an emery board. For high performance, the trailing edge may be tapered instead of just rounded. This will result in lower air drag during flight. Leave the fin tip flat, and squared off.

E The root edge of the fin, the edge that is attached to the body tube, must be perfectly flat if it is to have a strong joint when glued. Set a fin on the edge of a table, then wrap fine sandpaper around a block of wood. Hold the sandpaper block at right angles ( $90^\circ$ ) to the fin and sand the fin root in an up and down motion - very lightly (Fig. 9). Do this until the root edge is completely flat. Test to see if it sits flat by placing the root edge on a flat surface (such as a table top). Repeat for the other fins.

Fig. 7

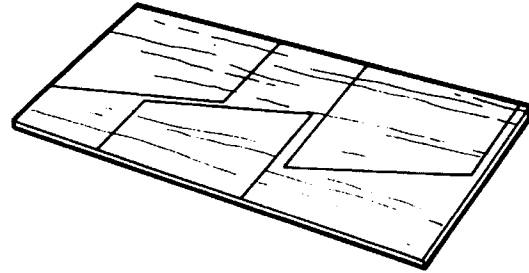

Fig. 8

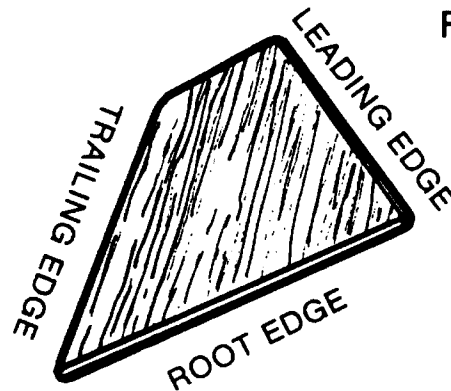
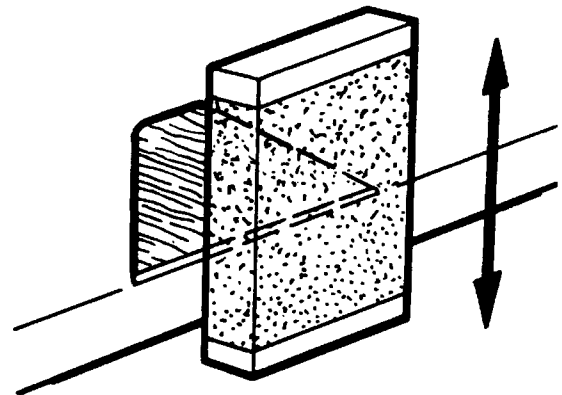

Fig. 9



## ASSEMBLY OF THE ENGINE MOUNT

- A Mount the engine retainer wire by cutting a small slit in the engine tube 7 mm (ET-100) from one end (Fig. 1). Push the end of the retainer into the slit.
- B Test fit a centering ring to slide onto the tube, and over the engine retainer. If it will not slide on easily, then peel a layer of paper from the inside of the ring (Fig. 2).
- C Spread glue around the outside of the engine tube 4cm from the front. Slide a centering ring onto the tube from the front, over the retainer wire and position it 4 cm from the front (Fig. 3).
- D Spread glue around the outside of the engine tube at the front. Slide the other centering ring onto the tube so that it is positioned even with the front of the tube (Fig. 4). Set the engine mount aside to dry.
- E Put a double wrap of masking tape around the engine tube between the two centering rings. This will help keep the retainer from being pushed forward.

Fig. 1

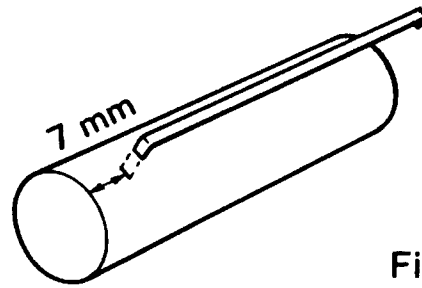

Fig. 2

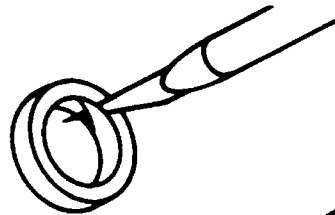

Fig. 3

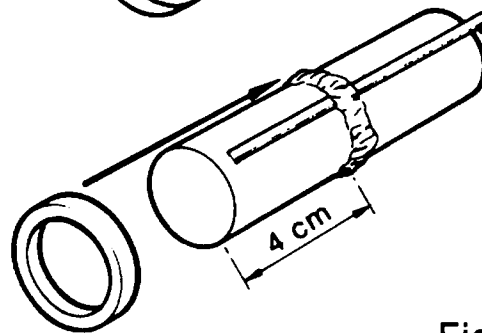

Fig. 4

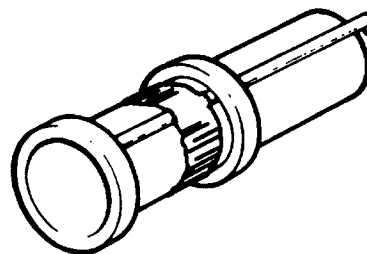

Fig. 5

## INSTALL THE ENGINE MOUNT

- A Test fit the completed engine mount into the body tube. If the mount does not easily slide into the tube, then remove the outer layer of paper from the centering rings. Both rings should now slide easily into the tube.
- B Place glue on the end of your finger, place the finger into one end of the body tube and smear the glue around in a ring on the inside of the tube. Do this again until you have made a thick ring of glue in a complete circle inside the tube, about 6.5cm up (Fig. 5).
- C Slide the engine mount into the body tube until the engine tube is even with the end of the body tube. Leave the retainer wire sticking out (about 7mm) (Fig. 6).

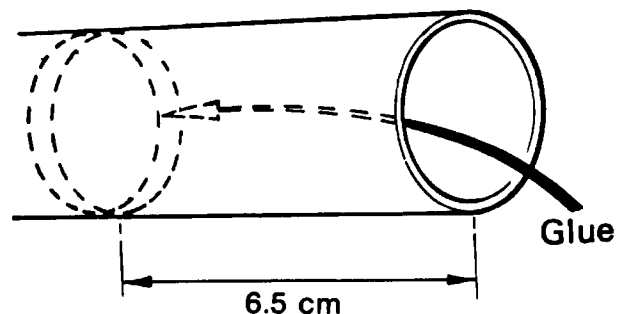
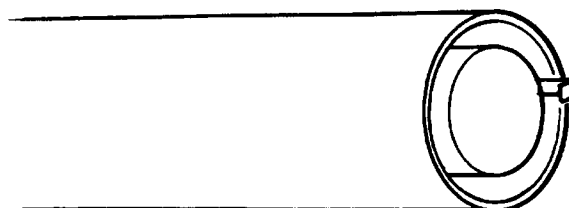

Fig. 6



## FINISHING THE Balsa PARTS

Raw balsa is unsightly, coarse and grainy, if painted before the grain is "filled" and the surface is "sealed". Model rockets look professional if the time is taken to finish the balsa. The Guide to Spacemodelling contains tips on finishing and may be consulted for assistance.

- A The most common method of finishing balsa uses Butyrate Dope, available from most hobby outlets. To assist in filling the balsa grain, cornstarch, talc, or baby powder may be rubbed into the balsa and worked into the grain. Brush on a thick coat of dope, be sure to do both sides of each fin at the same time in order to avoid warping.
- B After the dope dries completely, lightly sand the balsa surfaces with fine sandpaper. The sanding operation removes the excess thickness of dope and speeds up the process of filling the grain.
- C After repeating the doping/sanding operation three or four times, the balsa grain should be filled and the surfaces smooth. The last sanding operation should be done with extra fine sandpaper.

Fig. 10

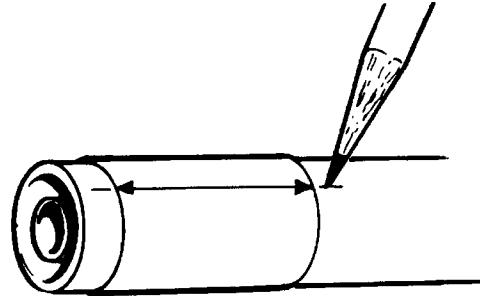

Fig. 11

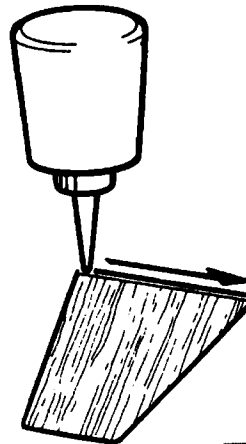
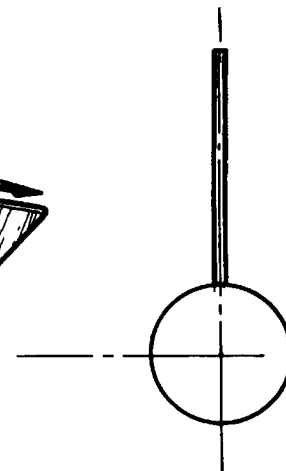

Fig. 12



## 4. MOUNTING THE FINS

- A Cut out the fin placement guide from the pattern sheet.
- B Wrap the guide around the rear of the body tube (the end with the engine mount), and tape the ends together.
- C Place a mark on the body tube where each fin position is shown by an arrow on the guide. These marks will show you where to align the fins when glueing them to the tube (Fig. 10).
- D Place a line of glue along the root edge of a fin (Fig. 11). Place the fin on the rear of the tube along the alignment marks. Set aside until the glue has set. Be sure that the fin is sitting at  $90^\circ$  to the tube when viewed from the end (Fig. 12).
- E Repeat the procedure to glue on the other fins. All fins should be evenly spaced around the tube when completed.
- F Once all the fins have dried, lay a thin line of glue along each fin joint to form a "fillet" and strengthen the fin. Smooth out the line of glue neatly with the tip of your finger.

### SHOCK CORD MOUNT

- A Cut out the shock cord mount from the pattern sheet.
- B Construct the mount as shown in Fig. 13. Fold the panels so that the shock cord rolls with it.
- C Spread glue on the folded side of the mount and insert it into the front of the body tube at least 5cm. Press it firmly against the wall of the tube (Fig. 14).

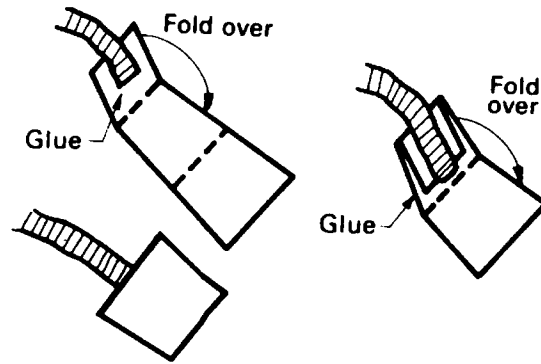
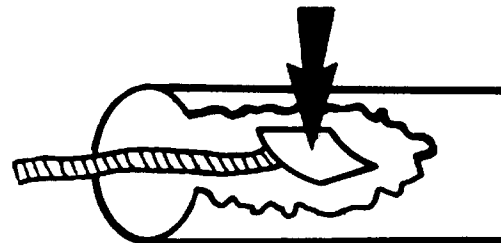

Fig. 13

Fig. 14



### ATTACHING THE NOSE CONE

- A Pierce a hole with the modelling knife for shock cord attachment (Fig. 15).
- B Tie the free end of the shock cord to the eyelet and make a solid knot.
- C Trim off and sand smooth any flash along the seam of the nose cone.

Fig. 15

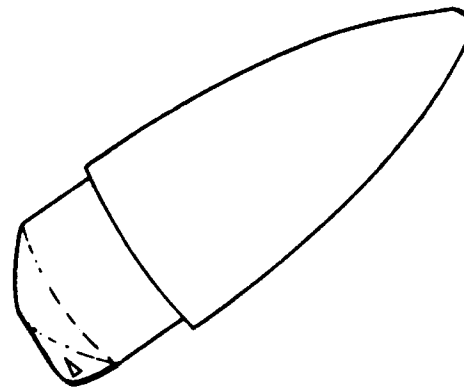

### PARACHUTE

- A Construct the parachute as instructed on the pattern.
- B Tie the knotted end of the parachute shroud lines to the eyelet in the base of the nose cone.

### LAUNCH LUG

- A Glue the launch lug along on of the fin joints.

### PAINTING

- A Whether brushing or spraying, a base coat of white should always be applied. Paint should always be applied in thin coats to speed the drying and prevent unsightly "sags".

**B** Final colors may be applied over the base. Where necessary, masking tape may be used to separate colors. If spraying, cover the remaining areas with plastic wrap or paper.

**C** When spray painting, hold the can about 20cm to 30cm from the model, and spray in even strokes. Do not apply the paint too thick, or it will "run" and leave a "sag" in the surface. When brushing, be sure that the paint is not too thick, so that it may be properly brushed out and not leave brush streaks on the surface.

**D** When the final coat is dry, remove the masking tape by slowly peeling it back against itself, being careful not to peel off the base coat.

## DECALS

To apply decals please follow instructions on back of decal sheet.

## FLYING

**A** Install the engine simply by sliding it into the engine tube until it is locked firmly between the two ends of the engine retainer wire.

**B** Push down a piece of heat wadding into the top of the tube. The wadding serves to protect the plastic parachute from melting by the hot gases of the engines ejection charge. There should be about 3cm thickness of wadding to create a good piston between the parachute and the engine.

**C** Fold the parachute in the following manner:

- hold the tip of the parachute with one hand and the shroud lines with the other.
- gather together all of the free corners so that the parachute forms a triangle.
- fold over the corners.
- fold over the parachute into thirds.
- wrap shroud lines around the bundle.

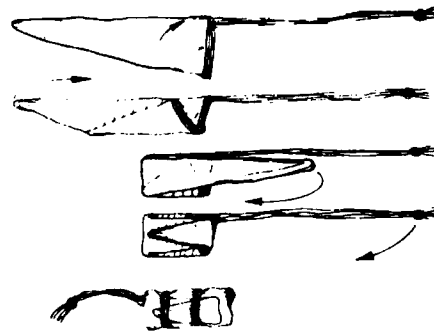

**D** Insert the parachute into the tube. Push in the shock cord and remaining shroud lines, then slide on the nose cone.

**E** Install an igniter into the engine according to the instructions provided with the engine.

**F** Slide the rocket onto the launch rod, sliding the rod through the launch lug. This will guide the rocket at the moment of launch.

**G** Attach the igniter clips to the leads of the igniter.

**H** Insert the safety key into your launch controller, give a 5-second countdown and press the button to launch your model.

For further tips see Canaroc's GUIDE TO SPACEMODELLING.

**CANAROC**



MANUFACTURED BY  
IRWIN TOY LTD.  
43 Hanna Avenue  
Toronto, Canada  
M6K 1X6



SHOCK CORD ANCHOR  
CORDON AMORTISSEURS

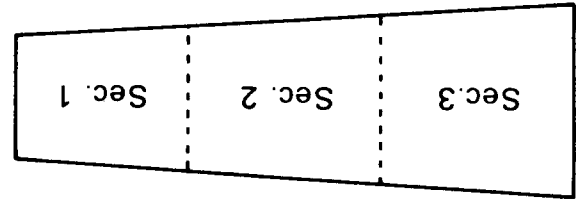
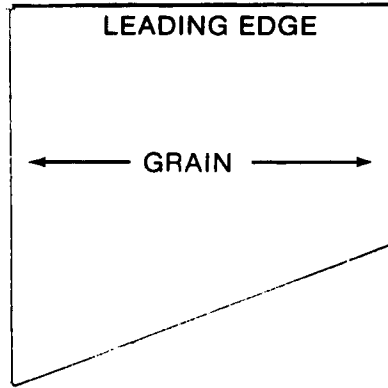
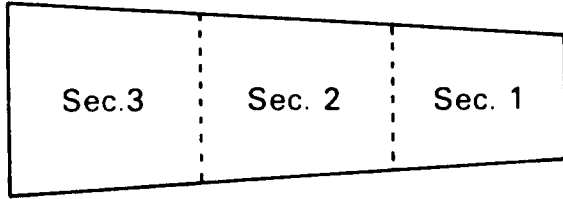

SHOCK CORD ANCHOR  
CORDON AMORTISSEURS

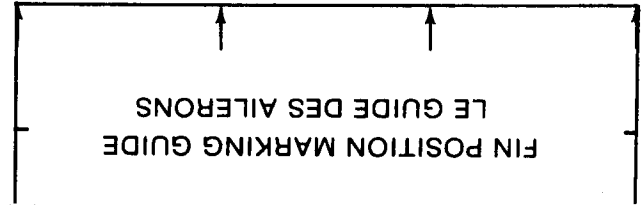
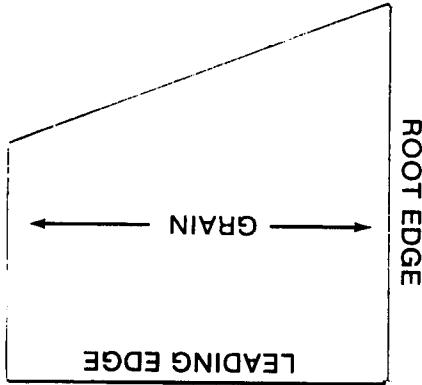

TODAY  
1968

S T W T F S  
JANUARY 1 2  
4 5 6 7 8 9  
11 12 13 14 15 16  
18 19 20 21 22 23  
25 26 27 28 29 30

FEBRUARY 1  
1 2 3 4 5 6  
8 9 10 11 12 13  
15 16 17 18 19 20  
22 23 24 25 26 27

MARCH 1 2 3 4 5 6  
8 9 10 11 12 13  
15 16 17 18 19 20  
22 23 24 25 26 27

APRIL 1 2 3  
5 6 7 8 9 10  
12 13 14 15 16 17  
19 20 21 22 23 24  
26 27 28 29 30

MAY 1 3  
4 5 6 7 8  
10 11 12 13 14 15  
17 18 19 20 21 22  
24 25 26 27 28 29  
31

JUNE 1 2 3 4 5  
7 8 9 10 11 12  
14 15 16 17 18 19  
21 22 23 24 25 26  
28 29 30

JULY 1 2 3  
5 6 7 8 9 10  
12 13 14 15 16 17  
19 20 21 22 23 24  
26 27 28 29 30 31

AUGUST 1 2 3 4 5 6 7 8  
10 11 12 13 14  
16 17 18 19 20 21  
23 24 25 26 27 28  
30 31

SEPTEMBER 1 2 3 4  
6 7 8 9 10 11  
13 14 15 16 17 18  
20 21 22 23 24 25  
27 28 29 30 31

OCTOBER 1 2  
4 5 6 7 8 9  
11 12 13 14 15 16  
18 19 20 21 22 23  
25 26 27 28 29 30

NOVEMBER 1 2 3 4 5 6 7  
9 10 11 12 13  
15 16 17 18 19 20  
22 23 24 25 26 27  
29 30

DECEMBER 1 2 3 4  
6 7 8 9 10 11  
13 14 15 16 17 18  
20 21 22 23 24 25  
27 28 29 30 31



**FK-3**

**CANADA**

**82320**

**CANADIAN  
ARMED FORCES  
FORCES ARMÉES  
CANADIENNES**

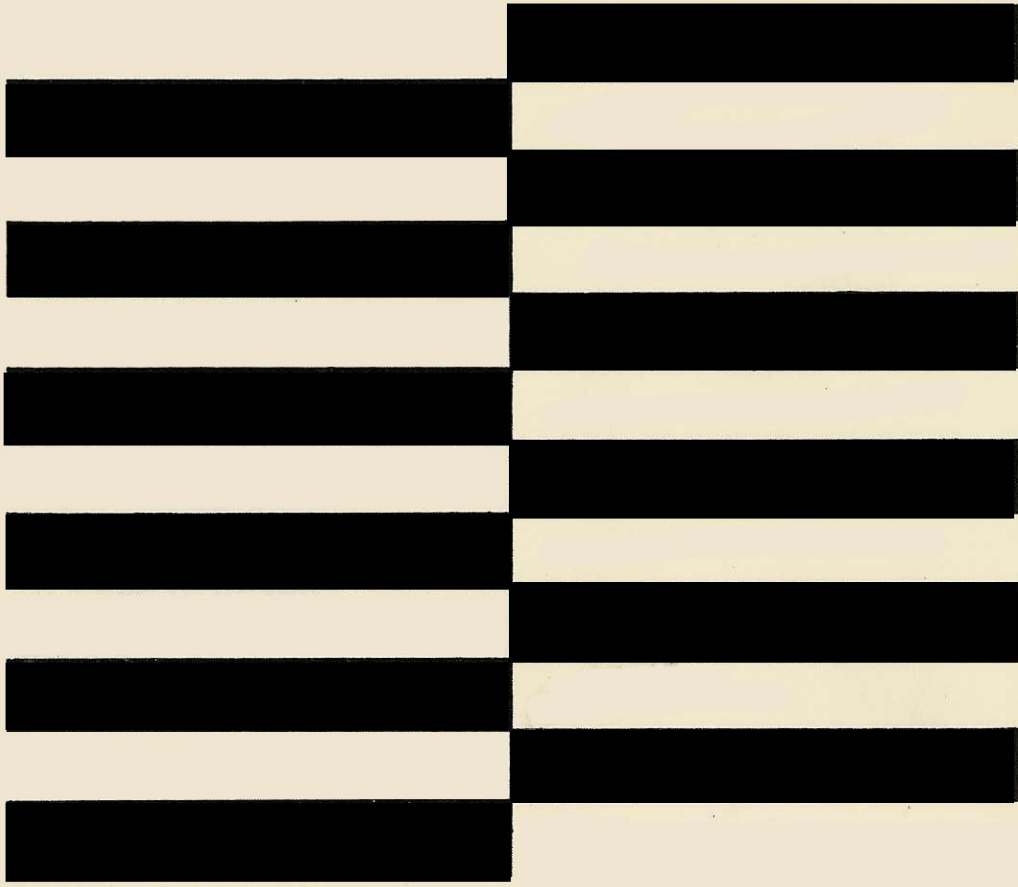

**FK-3**

**CANADA**

**82320**

**CANAROC** 

**CANADIAN  
ARMED FORCES  
FORCES ARMÉES  
CANADIENNES**

**CANAROC** 

