

Place on WHITE SIDE of hinge material. (Make 2)

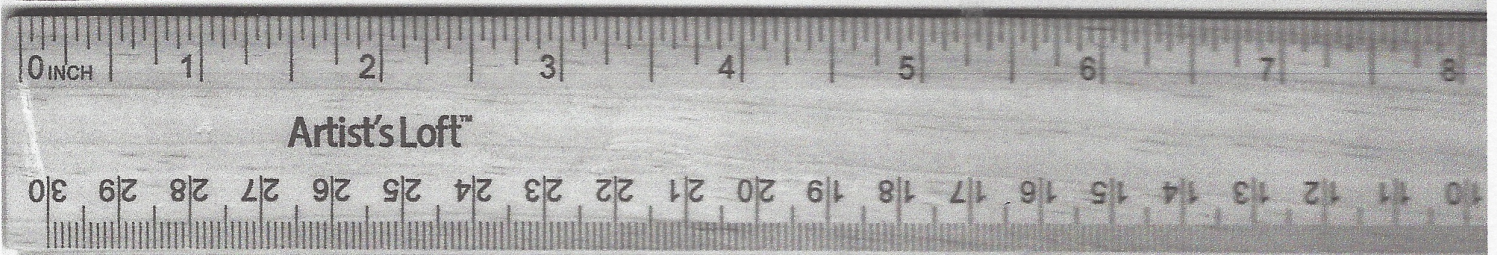
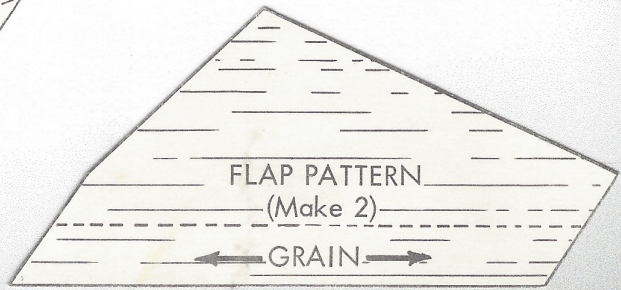
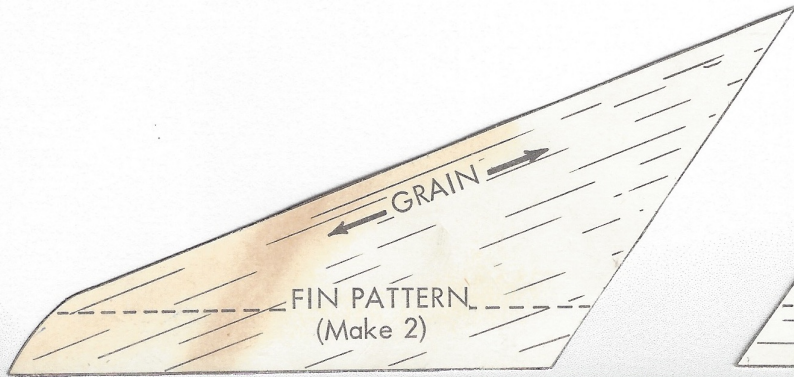
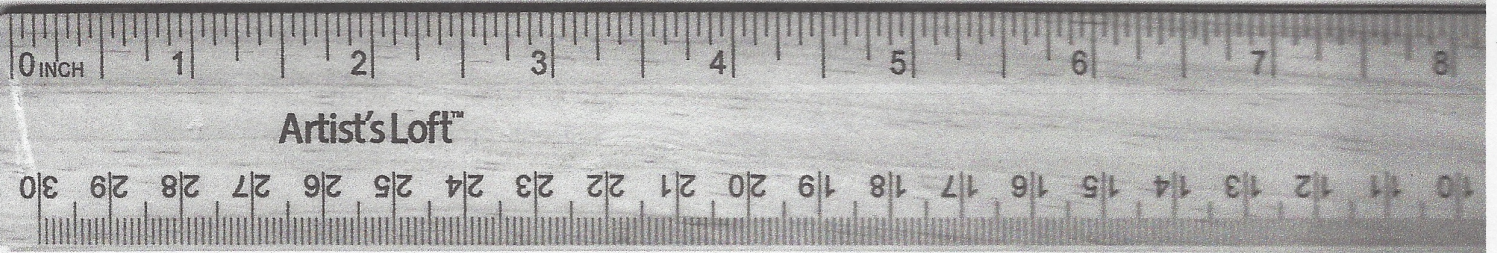
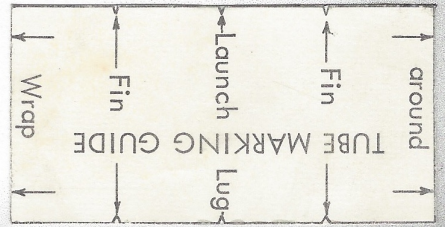
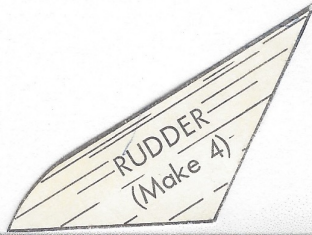

PATTERN SHEET
SP-24

K-24 GYROC

FLAP HOLDER
PATTERN (Make 2)

A diagram of a flap holder pattern, which is a rectangular shape with a semi-circular cutout on one side.

STEP 6

□ Step 6. Apply glue to the fin part of one assembly and place on a fin guide line. Sight down the side of the body tube making sure the fin is placed in line with the centerline of the tube and sticks straight out from the tube. Allow the glue to set. Attach the other fin-flap assembly in the same way. Set the rocket on its nose while the glue dries. Trim the launching lug if desired and glue it into place as shown.

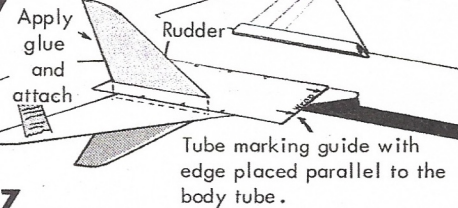
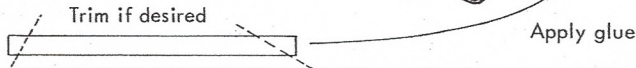

STEP 7

□ Step 7. Use the tube marking guide as shown to glue the rudders into position. Place them to stick straight away from the fin on either side. (See the rear view of the general layout illustration.)

STEP 8

□ Step 8. Place an engine casing into the body tube. Apply glue to a hardwood tab and put the tab on the flap on the side opposite the hinge. As shown, position the tab with the square side just touching the engine casing. Apply the other tab in the same way. View your model from the rear and compare the rear view of the general layout with it.

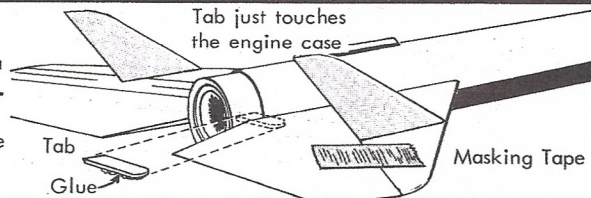

STEP 9

□ Step 9. Glue the nose cone into place.

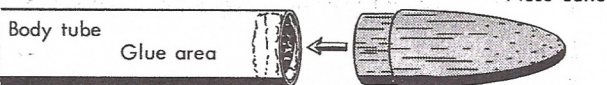

STEP 10



□ Step 10. Remove the masking tape from the fin-flap joint. PAINT the model the color(s) of your choice. The elastic thread is installed as the last construction step.

□ Step 11. Thread the elastic thread through the eye of the needle, and knot the other end of the thread. Hold one flap against its rudder and push the needle through the flap from the back. The needle point should come out through the hinge $1/16$ " from its rear edge. Draw the elastic thread through until the knot is seated against the flap. Apply a touch of glue to the knot side forcing just enough glue through the hold to appear on the hinge side. Allow this glue to set. Locate a point $1/2$ " up from the root edge and $1/8$ " back from the leading edge of the rudder. Push the needle through and draw the thread tight enough to pull the flap from a straight position to full flap position. Apply glue as you did on the flap and hold the elastic thread in this position until the glue appears firmly set.

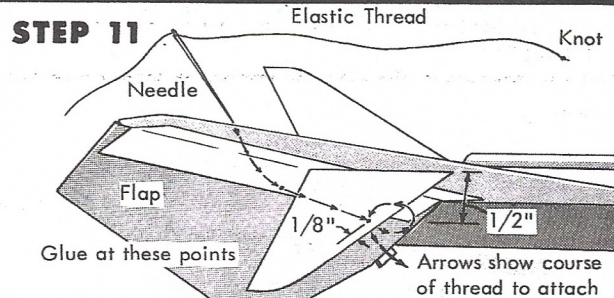

GENERAL LAYOUT

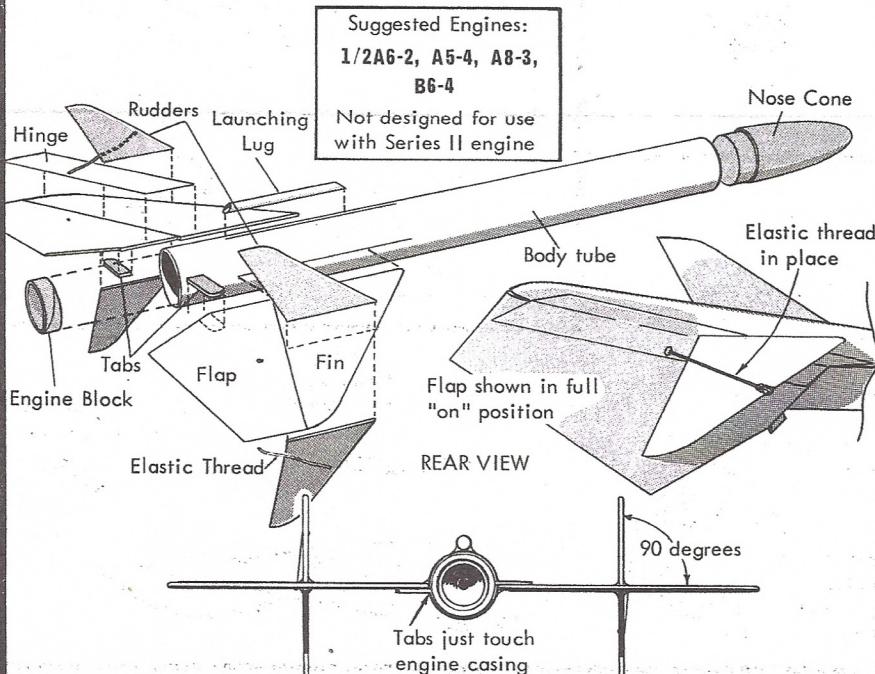

COUNTDOWN LIST

- 10. Select an engine and insert an igniter following the instructions that came with the engines.
- 9. Hold flaps in their neutral position and slide the engine into place. No tape is needed -- just release the flaps.
- 8. Place the rocket on the launcher. Clean and attach the clips to the igniter leads.
- 7. Clear the area, check for low flying aircraft, alert recovery, timer, and tracking crews.
- 6. Arm the launch-controller and check continuity.
- 5- □-4- □-3- □-2- □-1- LAUNCH!

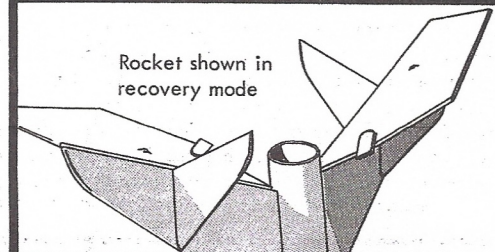

ASSEMBLY

STEP 1

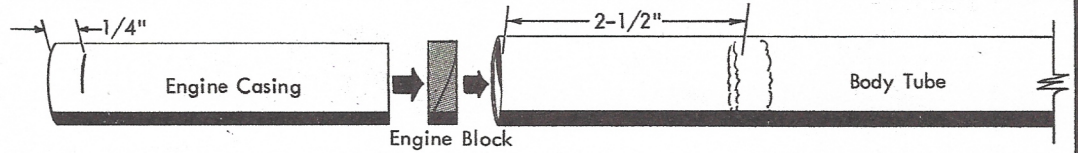

- Step 1. Mark an engine casing 1/4" from one end for use as a depth guide. Apply glue to the inside of one end of the body tube at a depth of 2-1/2". Insert the engine block into this end and press it into place with the marked engine casing.

STEP 3

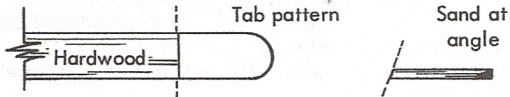

- Step 3. Cut out the flap holder pattern and from the hardwood piece, cut two holders. Sand the square edge to a slight angle as shown. Set aside for later installation.

STEP 4

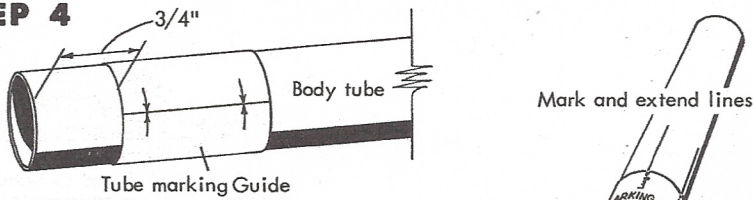

- Step 4. Cut out the tube marking guide and wrap it around the rear of the body tube 3/4" from the end. Match the end arrows carefully and mark the body tube at both fin and launching lug notches. Remove the guide and connect the marks with a straight line. Carry all lines toward the front end of the tube at least 3" as is shown. (Save the guide. It will be used later.)

STEP 5

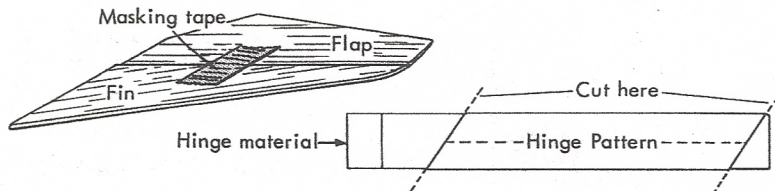

- Step 5. Tape the fins and flaps together as shown. Cut out the hinge pattern and cut one hinge from each piece of material provided. Strip the backing paper from a hinge piece and apply it as shown. Do the same to the other hinge and fin-flap assembly. Remove the masking tape and bend the flap back flat against the fin to create the hinge. The flap will stay bent slightly. To facilitate handling, replace the piece of masking tape to hold the assembly flat.

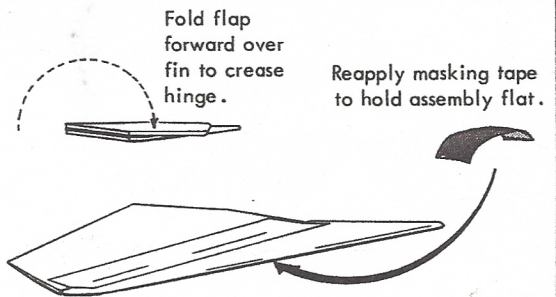
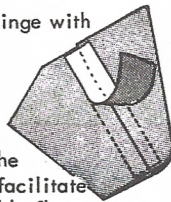

STEP 2

- Step 2. Cut the rudder, fin, and flap patterns from the pattern sheet. Lay out fin and flap patterns first as shown then the rudder pattern. Trace around each with a ball point pen. Cut out and sand all the parts as shown.

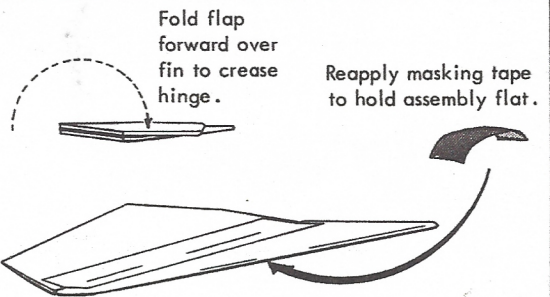
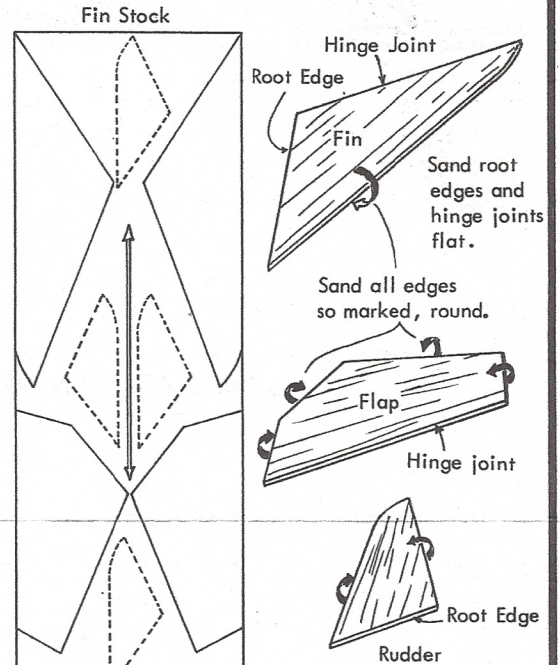

K-24

Astron GYROC

HELICOPTER
RECOVERY

RECOMMENDED
ENGINES
1/2A6-2, A5-4,
A8-3, B6-4



Industries, Inc. 
Devoted to Safety and Education in Rocketry
Box 227,
Penrose, Colorado

Only
\$1.25
SCIENTIFIC SPACE AGE HOBBY

PARTS

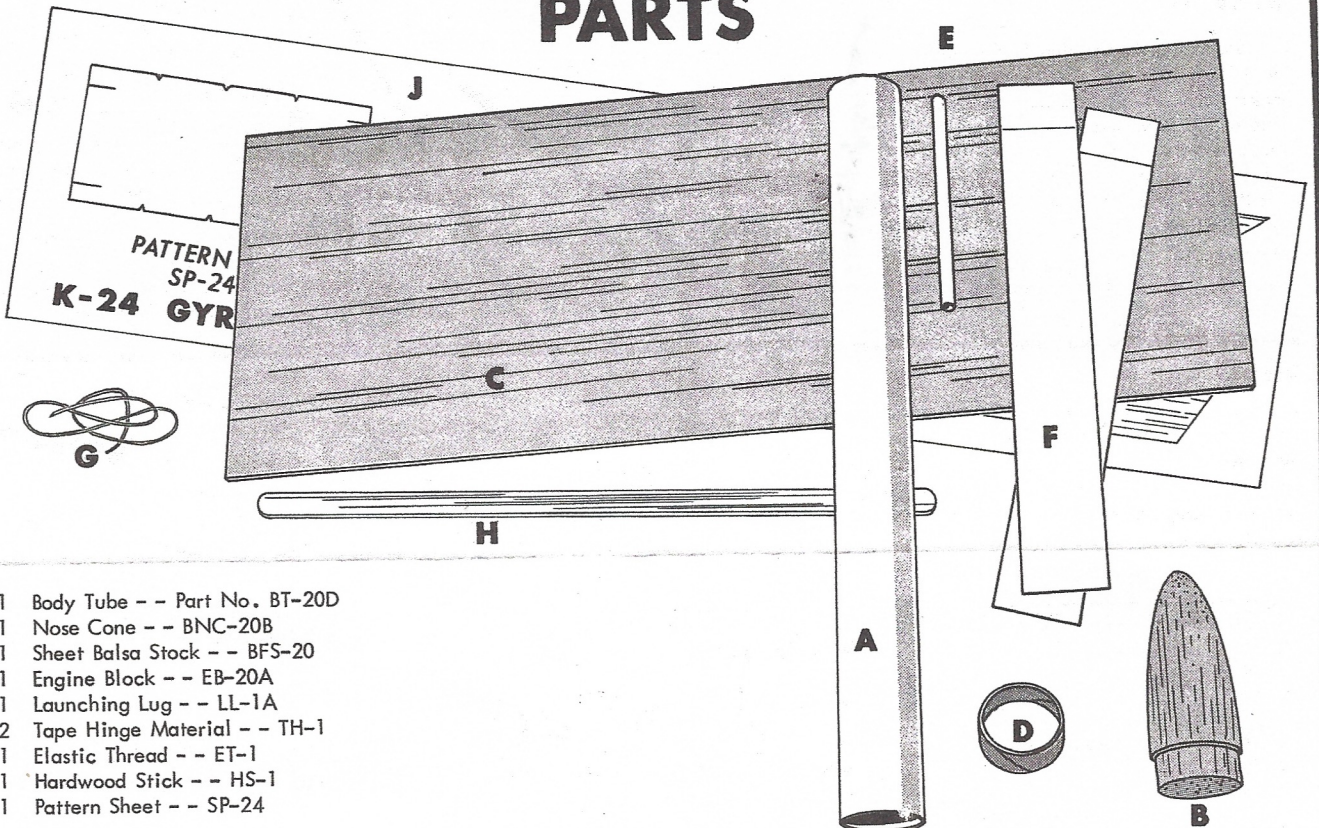

- A 1 Body Tube -- Part No. BT-20D
- B 1 Nose Cone -- BNC-20B
- C 1 Sheet Balsa Stock -- BFS-20
- D 1 Engine Block -- EB-20A
- E 1 Launching Lug -- LL-1A
- F 2 Tape Hinge Material -- TH-1
- G 1 Elastic Thread -- ET-1
- H 1 Hardwood Stick -- HS-1
- J 1 Pattern Sheet -- SP-24