



Model Rocket Safety Code

- 1. Materials.** I will use only lightweight, non-metal parts for the nose, body, and fins of my rocket.
- 2. Motors.** I will use only certified, commercially-made model rocket motors, and will not tamper with these motors or use them for any purposes except those recommended by the manufacturer.
- 3. Ignition System.** I will launch my rockets with an electrical launch system and electrical motor igniters. My launch system will have a safety interlock in series with the launch switch, and will use a launch switch that returns to the "off" position when released.
- 4. Misfires.** If my rocket does not launch when I press the button of my electrical launch system, I will remove the launcher's safety interlock or disconnect its battery, and will wait 60 seconds after the last launch attempt before allowing anyone to approach the rocket.
- 5. Launch Safety.** I will use a countdown before launch, and will ensure that everyone is paying attention and is a safe distance of at least 15 feet away when I launch rockets with D motors or smaller, and 30 feet when I launch larger rockets. If I am uncertain about the safety or stability of an untested rocket, I will check the stability before flight and will fly it only after warning spectators and clearing them away to a safe distance.
- 6. Launcher.** I will launch my rocket from a launch rod, tower, or rail that is pointed to within 30 degrees of the vertical to ensure that the rocket flies nearly straight up, and I will use a blast deflector to prevent the motor's exhaust from hitting the ground. To prevent accidental eye injury, I will place launchers so that the end of the launch rod is above eye level or will cap the end of the rod when it is not in use.
- 7. Size.** My model rocket will not weigh more than 1,500 grams (53 ounces) at liftoff and will not contain more than 125 grams (4.4 ounces) of propellant or 320 N-sec (71.9 pound-seconds) of total impulse. If my model rocket weighs more than one pound (453 grams) at liftoff or has more than four ounces (113 grams) of propellant, I will check and comply with Federal Aviation Administration regulations before flying.
- 8. Flight Safety.** I will not launch my rocket at targets, into clouds, or near airplanes, and will not put any flammable or explosive payload in my rocket.
- 9. Launch Site.** I will launch my rocket outdoors, in an open area at least as large as shown in the accompanying table, and in safe weather conditions with wind speeds no greater than 20 miles per hour. I will ensure that there is no dry grass close to the launch pad, and that the launch site does not present risk of grass fires.
- 10. Recovery System.** I will use a recovery system such as a streamer or parachute in my rocket so that it returns safely and undamaged and can be flown again, and I will use only flame-resistant or fireproof recovery system wadding in my rocket.
- 11. Recovery Safety.** I will not attempt to recover my rocket from power lines, tall trees, or other dangerous places.

LAUNCH SITE DIMENSIONS

Installed Total Impulse (N-sec)	Equivalent Motor Type	Minimum Site Dimensions (ft.)
0.00 — 1.25	1/4A	50
1.26 — 2.50	A	100
2.51 — 5.00	B	200
5.01 — 10.00	C	400
10.01 — 20.00	D	500
20.01 — 40.00	E	1000
40.01 — 80.00	F	1000
80.01 — 160.00	G	1000
160.01 — 320.00	2 Gs	1500

MARS LANDER™

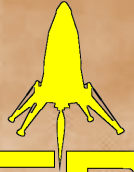

FUTURISTIC PLANETARY MANNED VEHICLE

GREAT DEMO BIRD

FUN TO BUILD AND FLY

WORKING SHOCK ABSORBING GEAR

BALSA NOSE CONE

LASER-CUT BODY PARTS

Designed by Wayne Kellner

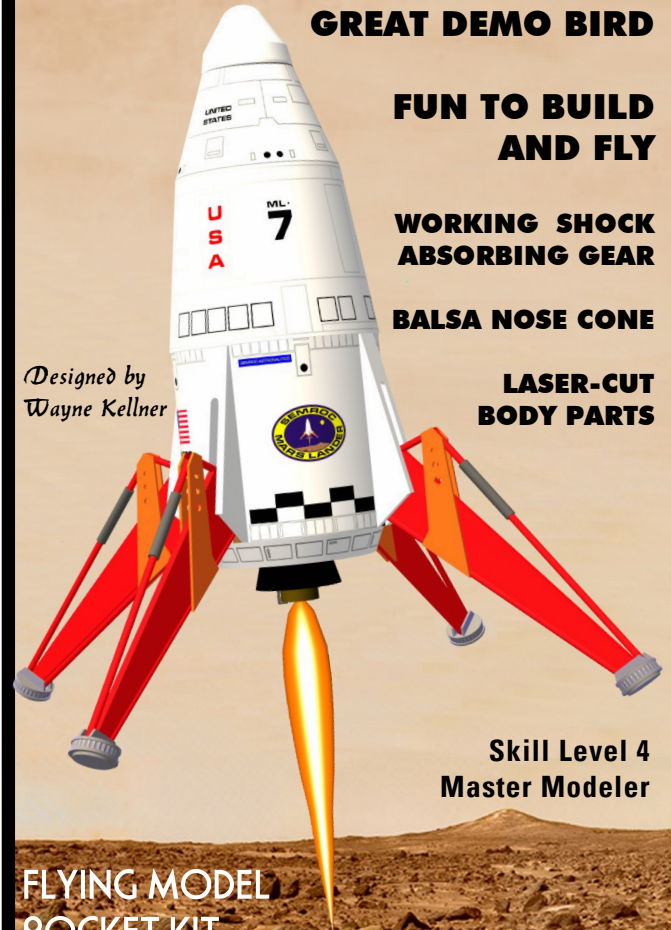

Skill Level 4 Master Modeler

FLYING MODEL ROCKET KIT



Made in the U.S.A by Semroc Astronautics Corporation - Knightdale, N.C. 27545

MARS LANDER™ Kit No. KV-54

Specifications	Engine	Approx. Altitude
Body Diameter	3.74" (5.9cm) B4-2	110'
Length	12.6" (31.9cm) B6-2	115'
Fin Span	13.2" (33.5cm) C6-3	360'
Net Weight	4.1 oz. (116.2g)	

Parachute Recovery

What is a Retro-Repro™?

A Retro-Repro™ is a retro reproduction of an out-of-production model rocket kit. It is a close approximation of a full scale model of an early historically significant model rocket kit from one of the many companies that pioneered the hobby over the past half century. A Retro-Repro™ is not a true clone or identical copy of the original. It incorporates improvements using modern technology, while keeping the flavor and build appeal of the early kits.

About Estes Industries, Inc.

In July 1958, G. Harry Stine of Model Missiles, Inc. in Denver, Colorado approached Vern Estes about making model rocket engines for them. On January 15, 1959, Vern's automated model rocket engine fabricating machine, "Mabel", produced the first of many millions of Estes model rocket engines. In 1960, Estes was producing more engines than Model Missiles could sell. Vern and his wife Gleda opened a mail order rocket company and introduced the Astron Scout and Astron Mark.

In 1961, a catalog was mimeographed and hand stitched on Gleda's sewing machine. Later that year, Estes Industries had outgrown the confined space in Denver. In December 1961, the entire operation was moved to an old farm in Penrose, Colorado quickly establishing the small town as the "Model Rocket Capital of the World."

Estes Industries was sold to Damon in September 1969. The name Estes is synonymous with model rocketry. Almost everyone remembers growing up firing Estes rockets or knowing someone that did. Estes Industries has introduced millions of youngsters of all ages to model rocketry for almost half a century.

March 9, 2006 Original Release
May 27, 2006 Revised

Copyright © 2006 Semroc Astronautics Corporation
Box 1271 Knightdale, NC 27545 (919) 266-1977

LIMITATION OF LIABILITY

Model rockets are not toys, but are functional rockets made of lightweight materials and are launched with NAR or Tripoli safety certified model rocket motors, electrically ignited and flown in accordance with the NAR Model Rocket Safety Code. If misused, model rockets can cause serious injury and property damage. Semroc certifies that it has exercised reasonable diligence in the design and manufacture of its products. Semroc cannot assume any liability for the storage, transportation, or usage of its products. Semroc shall not be held responsible for any personal injury or property damage whatsoever arising out of the handling, storage, use, or misuse of our products. The buyer assumes all risks and liabilities therefrom and accepts and uses Semroc products on these conditions.

Your purchase and use of any Semroc products is construed as your agreement to and acceptance of these terms. If you do not agree to these terms and conditions, you must return the product, unused, for refund or credit.

100% SATISFACTION GUARANTEE

If you are not 100% satisfied with your Semroc product, we will make it right by providing whatever you consider fair, from refund to replacement.

Contact us at:

Semroc Astronautics Corporation
Customer Service Department
P.O. Box 1271
Knightdale, North Carolina 27545

JOIN THE NAR!

Sign up online at www.nar.org to join the premier model rocketry organization. Semroc fully supports the National Association of Rocketry and recognizes it as the sport's official voice. The NAR is the oldest and largest sport rocketry organization in the world. Since 1957 over 80,000 serious sport rocket modelers have joined the NAR to take advantage of the fun and excitement of organized rocketry. It is always more fun if you fly with friends. The *Sport Rocketry* magazine is one of the best ways to keep informed of new developments in the hobby. Check online at www.semroc.com/nar for promotions just for NAR members.



FLIGHT PREPPING

❑ **65.** The Mars Lander™ is designed to fly with B6-2, B4-2, and C6-3 engines only. Only fly your Mars Lander™ in **little or no wind**. The Mars Lander™ is marginally stable due to its short, squat shape. Without an engine, the dry Center of Gravity (CG) should be no more than **7.1"** from the top of the nose cone. That is about at the top of the gear hub slots. Use two pencils to balance the Mars Lander using the slots as fulcrum points. If the CG is more than 7.1" from the nose cone tip, a small amount of weight may be required in the nose cone to make the Mars Lander™ stable.

❑ **66.** Pack the recovery wadding from the top of the body tube. Use a sufficient quantity to protect the parachute, but not too much that it will interfere with the proper deployment of the parachute. For best results, only push the recovery wadding down far enough to allow room for the chute and cords.

❑ **67.** Fold the parachute and pack it and the shock cord on top of the recovery wadding. Slide the nose cone into place, making sure it does not pinch the shock cord or parachute. If you are flying with a B4-2 or a B6-2 engine, the parachute must be packed very loosely. Do not wrap the lines and shock cord around the parachute or it will not have time to unroll. The maximum altitude is only about 100 feet and a tightly rolled chute will take more distance to unroll before impact.

❑ **68.** Refer to the model rocket engine manufacturer's instructions to complete the engine prepping. Different engines have different igniters and methods of hooking them up to the launch controllers.

❑ **69.** Carefully check all parts of your rocket before each flight as a part of your pre-flight checklist. Launch the Mars Lander™ from a 1/8" diameter by 36" long or longer launch rod. Aim the rod as close to vertical as possible. The Mars Lander™ can not recover from any angle of attack greater than about 15 degrees. **Any wind or flights off vertical can result in unstable flights!**

❑ **70.** After each flight, remove the spent engine casing and clean the model thoroughly for many hours of fun flying with your Mars Lander™!

About the Mars Lander™

The Estes® Mars Lander was initially released in 1969. It was the first to use a functional shock absorbing landing gear. Following a trend to more complex model rockets, the Mars Lander was designed to challenge even more experienced modelers. Slow liftoff and low altitude made it ideal for demonstration flights. The Mars Lander was introduced as catalog #K-43 and had an introductory price of \$4.75.

The Semroc Mars Lander™ is a faithful recreation of the original. It uses laser-cut balsa fins and laser-cut fiber parts instead of the original die-cut parts. The fiber is also thicker for sturdier construction. High gloss embossed wraps are provided for authentic looks of the original. A slightly larger chute is provided for longer life and a gentler recovery. A Kevlar® cord is provided for better shock cord retention.

BEFORE YOU START!

Make sure you have all the parts included in this kit that are listed in the Parts List in the center of these instructions. In addition to the parts included in this kit, you will also need the tools and materials listed below. Read the entire instructions before beginning to assemble your rocket. When you are thoroughly familiar with these instructions, begin construction. Read each step and study the accompanying drawings. Check off each step as it is completed. In each step, test-fit the parts together before applying any glue. It is sometimes necessary to sand lightly or build-up some parts to obtain a precision fit. If you are uncertain of the location of some parts, refer to the exploded view in the center of these instructions. It is important that you always ensure that you have adequate glue joints.

TOOLS: In addition to the parts supplied, you will need the following tools to assemble and finish this kit. You will also need masking tape, wax paper, several straight pins, one round wooden toothpick and paper towels for cleanup.



ASSEMBLY

1. These instructions are presented in a logical order to help you put your Mars Lander™ together quickly and efficiently. Check off each step as you complete it and enjoy putting this kit together.

NOTE: The Mars Lander™ is not for inexperienced modelers. If you have not developed sufficient skills to build this kit, wait until you have built a few more models. It will wait for you. Patience is required as well as a careful review of each instruction before continuing. If you are ready for this challenge, "Let's go!"

PARTS IDENTIFICATION

2. There are many different balsa fins and fiber parts included in this kit. The balsa parts are obvious, but the fiber parts can be confusing. Use the guide below to identify the parts that are called out in these instructions. Some of the parts are similar, but will not work if exchanged. Some of the parts have a top and a bottom and must be installed correctly or other parts will not fit later. If you "goof," contact us and we can possibly help you out. The laser-cut rings and parts are messy. Use paper towels to wipe all the edges as you punch them out.

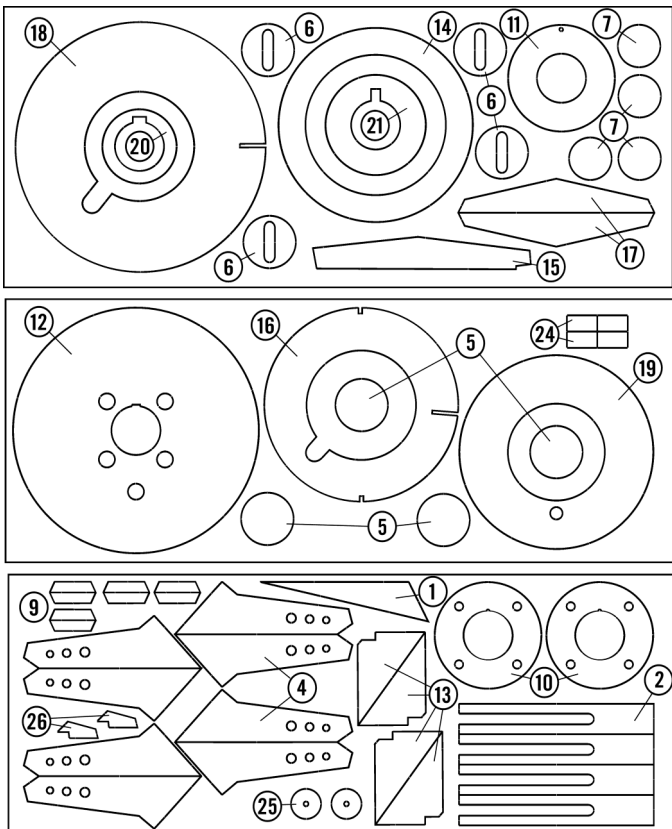

FINISHING

60. Prepare any remaining balsa surfaces for a smooth professional looking finish. Fill the wood grain with diluted Fill n' Finish or sanding sealer. When dry, sand with fine sandpaper. Repeat until smooth.

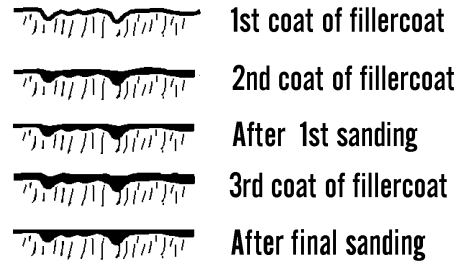

61. After all balsa surfaces have been prepared, wipe off all dust with a dry cloth. Cover the landing gear and the exhaust nozzle with paper and masking tape. The base color for the rest of the model is white.

62. Paint the Mars Lander™ using the following guide:

Overall Model	White
Landing gear	International Orange (or red)
Exhaust shroud	International Orange (or red)
Large Exhaust Ring	Black
Landing Gear Pads	Silver
Control Cylinders	Silver

63. Spray painting your model with a fast-drying enamel will produce the best results. PATIENCE...is the most important ingredient. Use several thin coats, allowing each coat to completely dry before the next coat. Start each spray a few inches above the model and end a few inches below the model. Keep the can about 12" away and use quick light coats. The final coat can be a little heavier to give the model a glossy wet-looking finish.

64. Refer to the photo on the front of the instructions for decal placement. The decals supplied are waterslide decals. Each decal should be cut separately from the sheet. Apply each decal before starting the next. Think about where you want to apply each decal and check for fit before wetting the decal. Soak each decal in water for about 30 seconds or until it slides easily off the backing paper. Slide the decal off the paper and onto the model surface. Blot dry using the backing paper.

RECOVERY SYSTEM

- ❑ **57.** Twist the screw eye into the base of the nose cone. Remove the screw eye and apply a squirt of glue into the hole. Re-insert the screw eye and twist into place. Allow the glue to dry.

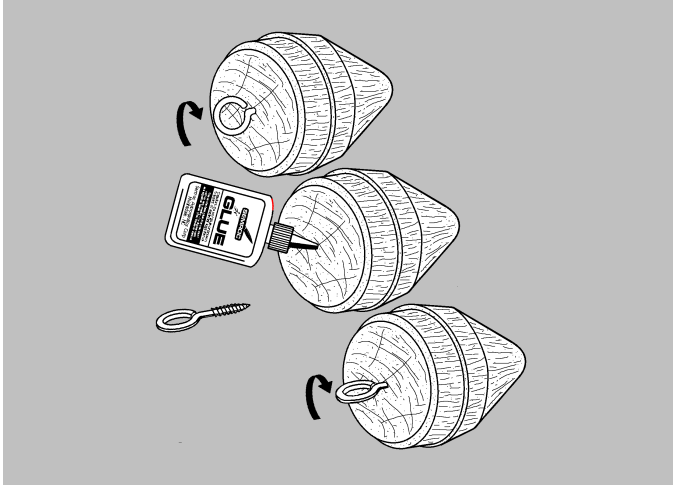

- ❑ **58.** Assemble the parachute using the supplied instructions. Before attaching the shroud lines, cut a spill hole out of the center of the chute using the template supplied. This will help with preventing spinning during descent. The parachute and spill hole combination was selected for optimum rate of descent to protect the model.

- ❑ **59.** Shake the Kevlar thread out of the top of the Mars Lander™. Tie it securely to the black elastic shock cord. Tie the other end of the elastic cord to the screw eye. Then attach the parachute to the screw eye.

*This completes the assembly
of your*

**MARS
LANDER**



BALSA PREPARATIONS

- ❑ **3.** Lightly sand each side of the laser-cut balsa fin sheet. Carefully push the laser-cut fins from the sheet. Start at one point on each fin and slowly and gently work around the fin.

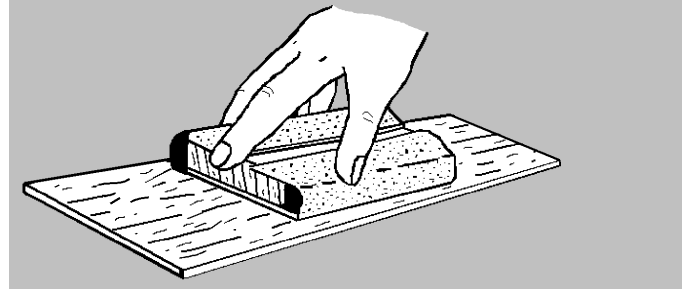

- ❑ **4.** Stack all the fins in groups of four fins each. Line each group up squarely and sand the fins back and forth over some fine sandpaper to get rid of the hold-in tabs as shown below.

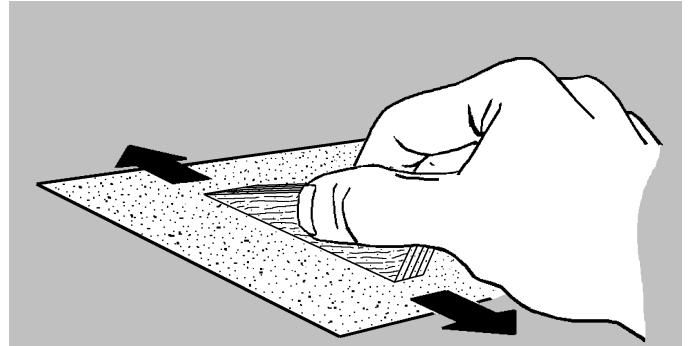

LANDING GEAR ASSEMBLY

- ❑ **5.** Remove the 4 fiber gear housing covers from the sheet. Apply glue along the second longest edge of the balsa gear housing as shown in the illustration and glue it in place. Make sure the outside edges are even. Be sure to wipe off the excess glue from the housing. Glue the second balsa gear housing just like the other side. Be sure you glue them on in the same direction. Using the same technique, assemble the other 3 housings.

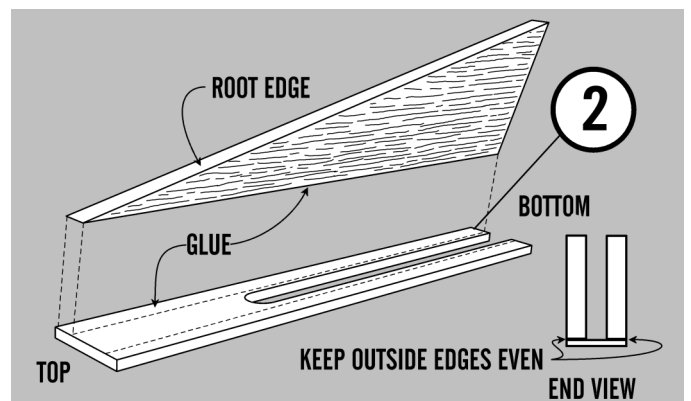

❑ **6.** Punch out the 4 balsa gear struts and round one of the edges as shown. Loop two rubber bands around the notch in each strut stretching them to the top of the strut. **Set two of the 1/8" dowels aside for Strut Brace C later.** All the dowels are not the same diameter. There is one that is thinner. Set it aside also. Cut four strut braces from the 1/8" wood dowels exactly the same size as the pattern supplied for brace (A) using a different dowel for each piece. Apply glue to the longest edge of one strut and then glue the strut brace to it leaving 9/16" of the end projecting from the rear of the assembly as shown. Repeat this with the other three struts.

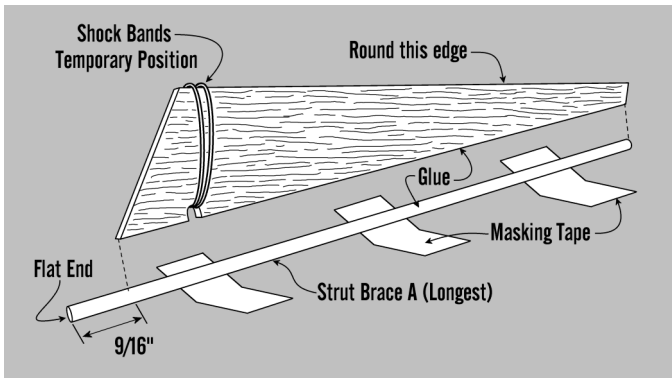

❑ **7.** Pull the rubber bands around so they hang freely from the brace as shown in the picture below. Using the pieces left over from cutting the Strut Brace A parts, cut 4 strut braces the same length as pattern (B). Apply glue and attach as shown to the 4 struts.

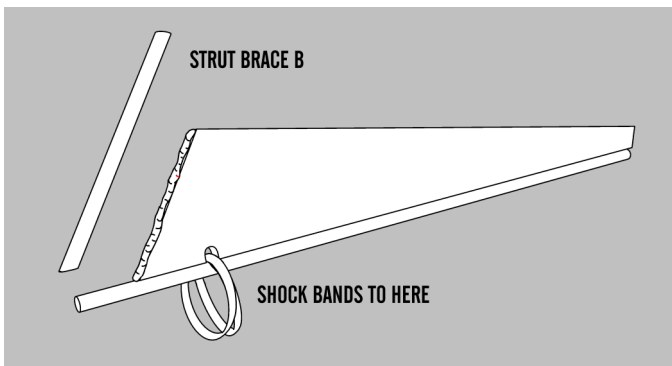

❑ **8.** Using the two 1/8" dowels you set aside, earlier, cut 4 braces exactly the same as pattern (C). Make sure that the diagonal cut on one end is sharper than the one on the other. Roll a thin piece of masking tape, cut 1/8" wide and 1-1/4" long around the dowel 3/4" from the tapered end as shown. Roll another piece of masking tape 2" from the tapered end as shown. Slide one of the LL-2A parts onto the strut brace as shown to make the control cylinder and glue into place. Repeat this procedure for the remaining three control cylinders.

❑ **55.** Apply a coat of glue on the back side of the rear descent stage body wrap and press it in between two of the gear housings and even with the rear of the descent body tube. Glue the other three in the same manner. Then apply a coat of glue to the four forward descent stage wraps. Apply them against the ascent module and in between the gear housings. Apply glue to one side of a RCS cover and glue as shown. Repeat for the other three.

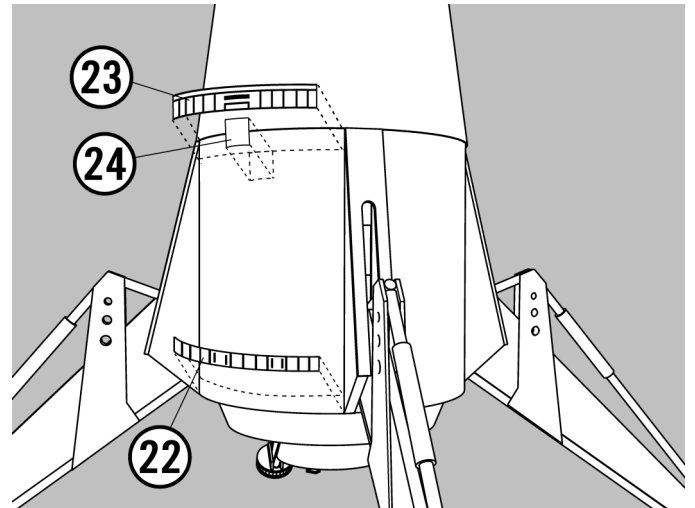

❑ **56.** Cut two 2" lengths from the 1/12" dowel. Apply glue 5/16" long from one dowel end. Center an antenna disk over the glue and allow to set. Cut two 5/16" lengths from each end of a wooden toothpick. Glue the wide end of the toothpick to the center of the antenna disk making sure it points straight out. After the glue has dried, run a line of glue along the backside of the antenna dowel and glue it to the ascent module shroud. Make sure the antenna points straight away from the module. Then glue the antenna trim piece to the bottom of the antenna.

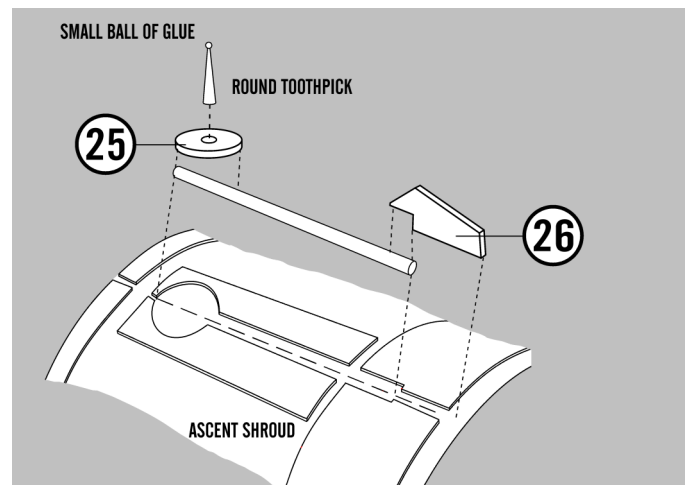

52. Next run a line of glue around the edge of the ascent bulkhead and around the forward end of the parachute tube. Slide on the command module making sure the launch lug is through the notch and glue into place. When the glue is dry cut away the top of the launch lug at an angle so that it is flush with the shroud.

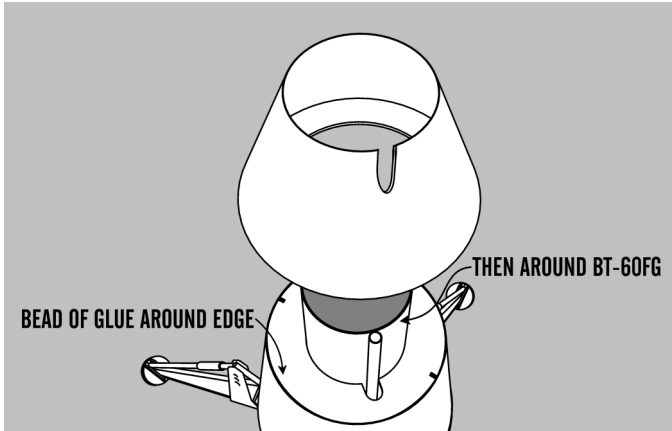

53. Apply a thin line of glue around the large end of the descent stage shroud. Pass the launch lug through the bulkhead hole and glue into place against the descent stage bulkhead. Be sure that it is centered and hold until it sets. Trim the bottom of the launch lug flush with the bulkhead.

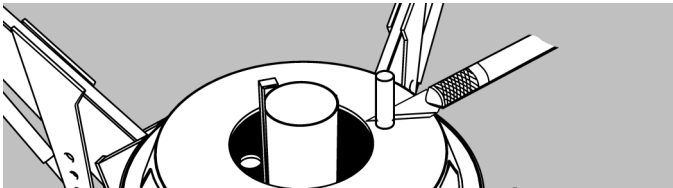

54. Slide the engine nozzle shroud onto the engine mount tube making sure that the engine hook passes through the notches in the rings. Position the large end of the nozzle even with the engine tube end. Make sure that the engine hook moves freely in the notches. Glue into place and hold until it sets.

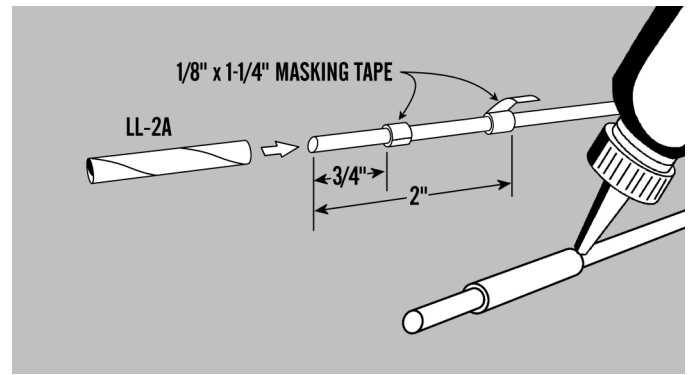
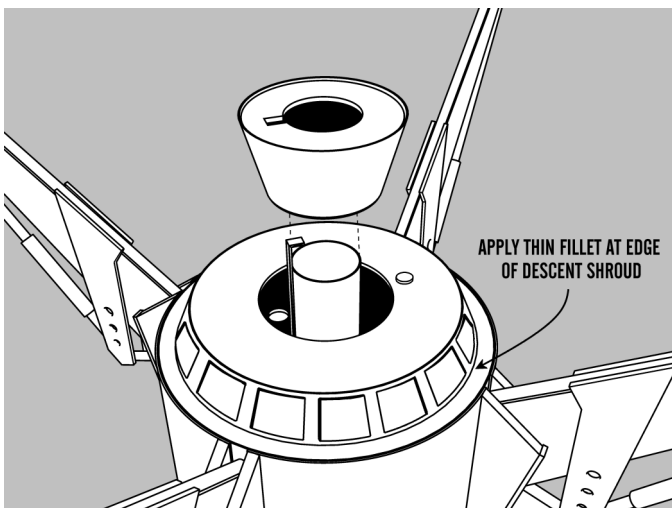

9. Mark each strut exactly $2 - 7/16$ " from the protruding end. Take one gear strut support and glue it into position as shown against the landing gear. Hold into place until the glue sets. Do the same with the other three landing gears.

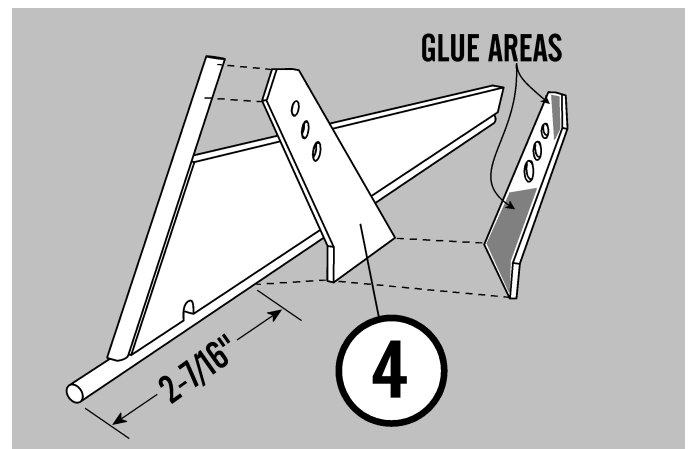

10. Apply glue to the gear support as shown in the illustration below. Glue the strut brace on with the control cylinder closest to the strut support. Be sure to glue the assembly exactly as shown below and repeat for the other 3 assemblies.

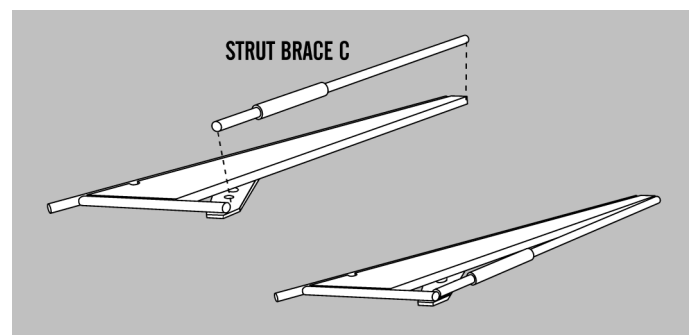

11. Glue the other gear support on to the assembly exactly as you did the first one and hold in place with masking tape until it sets. Repeat on the other 3 assemblies.

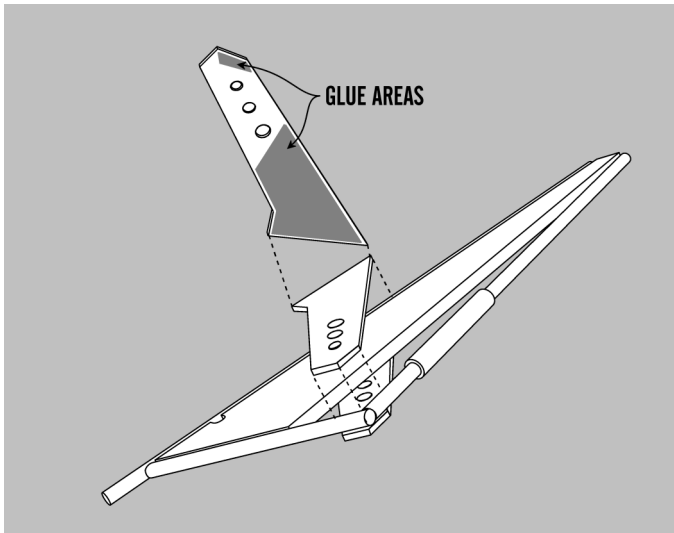

❑ **12.** Cut the strut wraps from the pattern sheet supplied. Apply glue to the printed side and center it on the bottom of Strut Brace (A) just before the slot that contains the shock bands. Repeat with the other 3 assemblies. Be sure not to get glue on the shock bands.

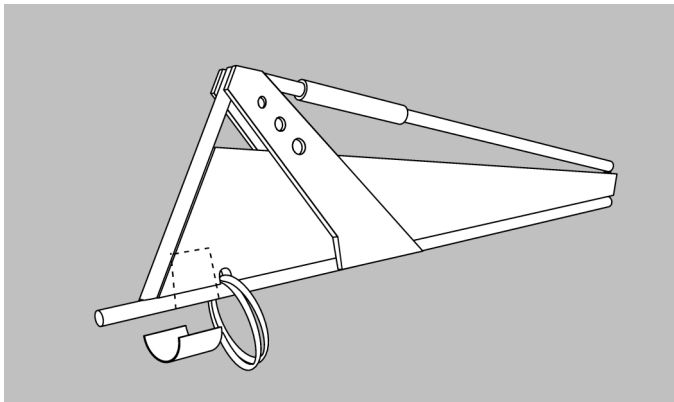

❑ **13.** Apply glue to the edge of the landing pad ring (EB-20B) and center it on the lower pad disk (5). Apply glue to the top edge of the landing pad ring. Center the upper pad ring (6) on the landing pad ring. Wipe off all excess glue. Make 3 more pads exactly the same.

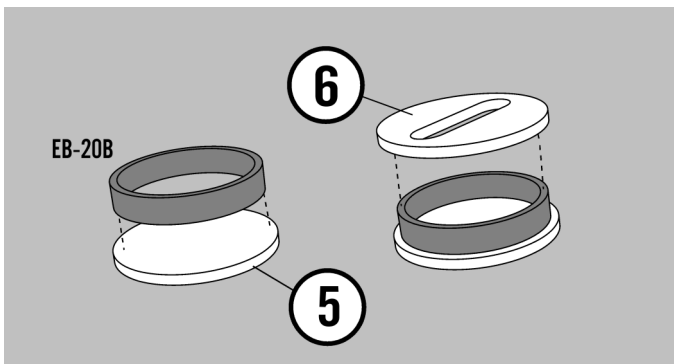

MODULE ASSEMBLY

❑ **49.** Slide the landing gear assembly into the descent stage tube. Make sure the bulkhead is aligned properly so that the landing gears move freely. **Do Not Glue!** Slide the ascent module on the parachute tube and fit the internal ring inside the descent stage. The wrap on the ascent stage should overlap the descent and be against the front of the gear housings. **Do Not Glue!** Slide the command module into place over the ascent module centering the notch over the launch lug. The command module should be even with the end of the parachute tube. Check everything for fit once more and make sure the landing gears move freely then glue the rear bulkhead into place. Let it dry completely.

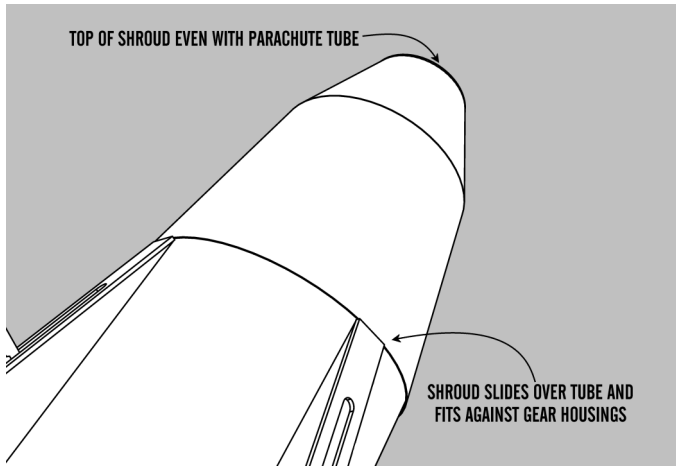

❑ **50.** Remove the command and ascent modules. Use a leftover piece of dowel to apply glue to the inside of the descent stage at the ring tube joint.

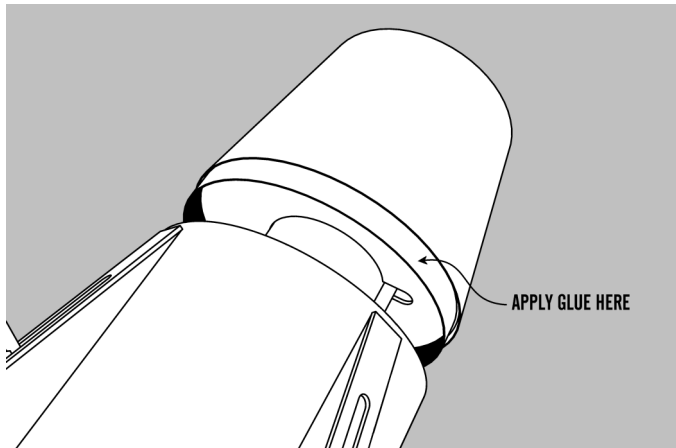

❑ **51.** Slide the ascent module part way onto the parachute tube. Run a line of glue around the module's internal ring. Slide the internal ring into the descent stage until the rear of the shroud is up against the front of the gear housings. Then apply a fillet of glue around the ascent module forward bulkhead at the body tube joint.

❑ **47.** Remove the landing gear assembly from the descent stage. Carefully cut 4 notches 1/4" long in the internal ring along the marks. Cut four 3/8" long pieces from the 1/12" dowel and glue them behind and centered with each notch. After the glue dries, trim any excess from the ring to allow the landing gear to rest against the dowels. This is critical for achieving correct landing gear span.

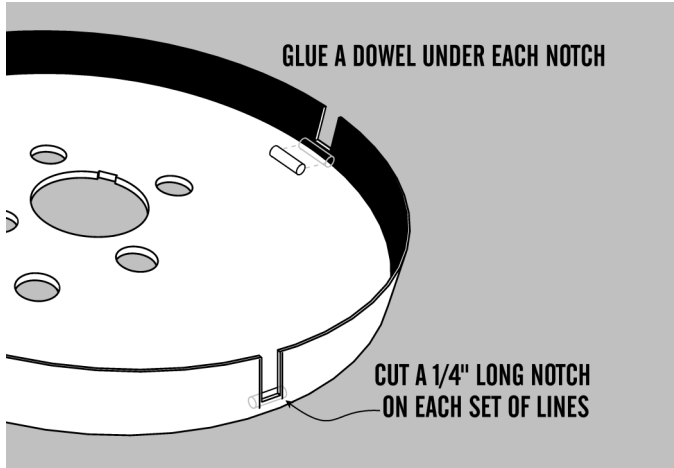

❑ **48.** Cut four 3/4" lengths from the 1/12" dowel. Pass a piece of string through the shock bands of one of the landing gears. Pass the free ends of the thread through the matching bulkhead openings. Pull the bands through using the string and slide one of the dowels through the bands and glue into place as shown below. Repeat with the remaining three legs. Measure the span from the outer edge of one landing pad to the opposite landing pad.. They should be about 13.2" apart, but no more than 13.5".

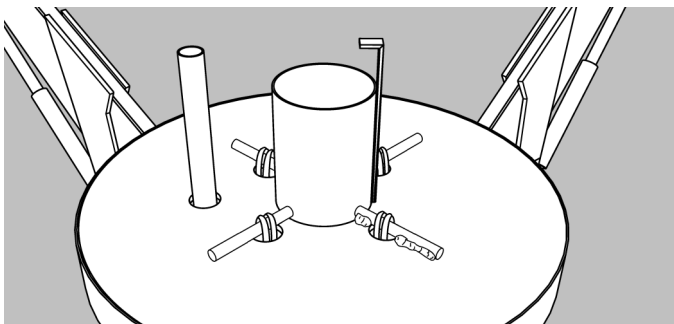
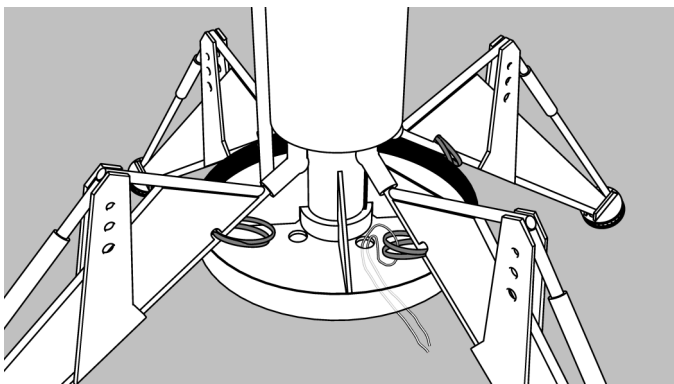

❑ **14.** Once the glue has set on the pads apply a small amount of glue to a small landing pad disk (7) and glue it to the bottom as shown. Glue one of the pad wraps (8) to the outside edge of the pad ring. Repeat this step for the other 3 pads.

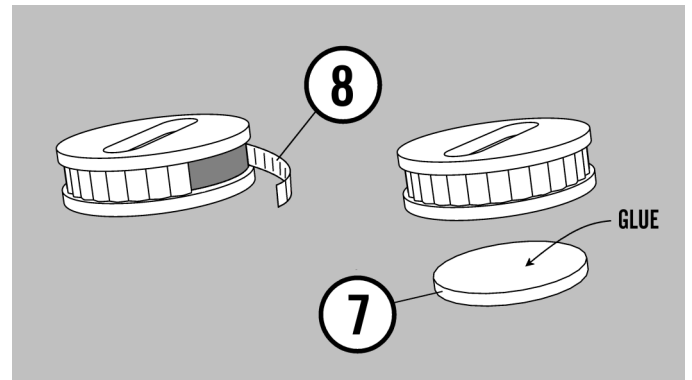

❑ **15.** Once the pads are dry apply a line of glue to the end of the gear strut. Pass the end of the strut through the slot in the pad and glue to the bottom disk as shown. Make sure the strut is perpendicular to the pad. Next glue the gussets (9) to the top of the pad and the side of the strut as shown. Do the same to the other 3 assemblies.

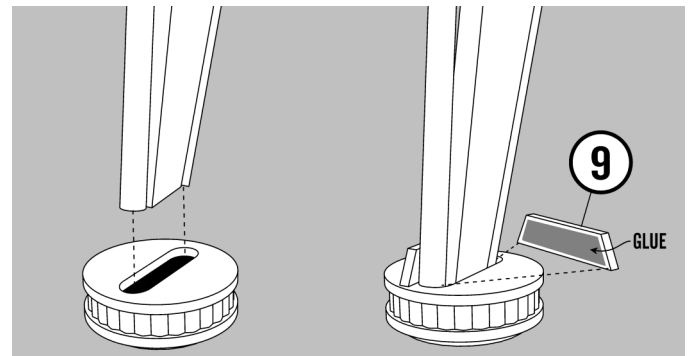

❑ **16.** Cut 4 hinge supports out of the 1/8" dowels left over from the previous instructions to the exact length on the pattern sheet provided. Apply a thin film of glue along one end for 1/2" and set it aside to dry. Do the same to the protruding end of the strut. The glue will provide some roughness to hold the dowels in the rubber hinge. **DO NOT GLUE TOGETHER!**

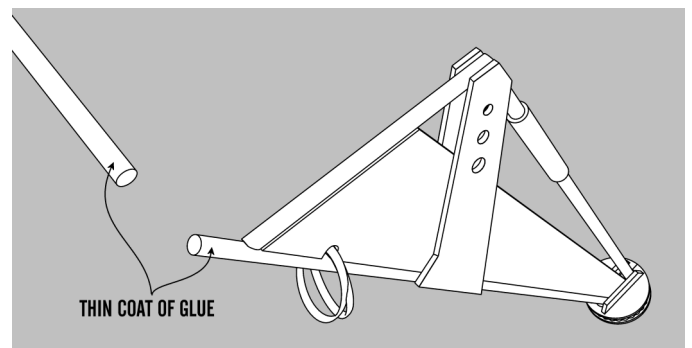

❑ **17.** While the glue is drying, insert one plastic bearing in each of the rubber hinges. Use your fingers to slowly work the bearing to the center of each rubber hinge tube. When all the glue is dry, slide one of the flexible hinge tubes onto the strut brace. Push it until the bearing seats against the dowel. If the bearing does not touch the dowel, trim a small amount off the end of the hinge tubing, re-center the bearing and try again. Then insert the hinge support into the other end of the tube until it **touches** the bearing from the other side. Repeat with the other 3 landing gears.

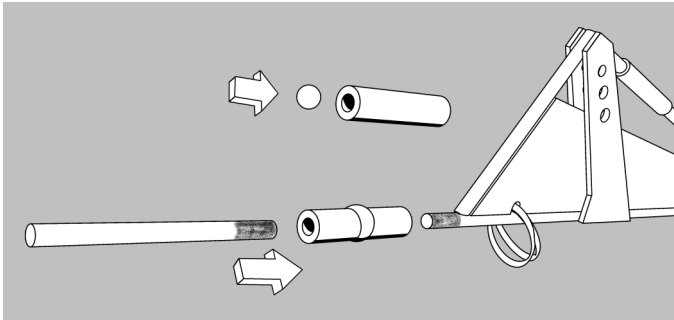

❑ **18.** After the glue has dried on the 4 landing gears, make a glue fillet on all the strut brace joints as shown in the illustration. Wipe it with your finger making a fillet and allow the glue to set. Do the same to both sides of the landing gear on the remaining three landing gears.

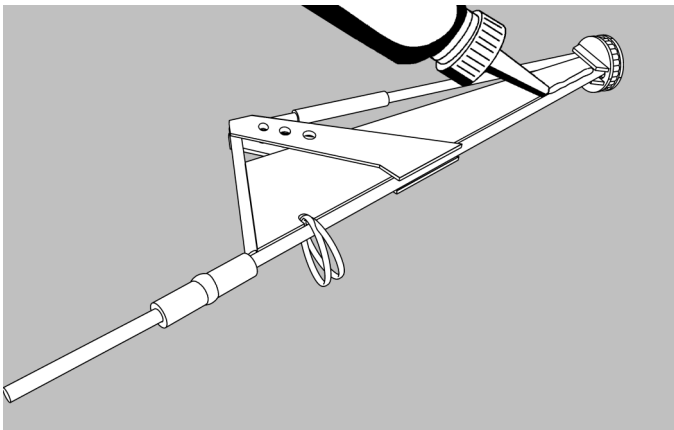

❑ **19.** Now that the landing gears are assembled and the glue is dry you may apply sanding sealer to them. Apply sparingly to keep the weight down. We recommend using Elmer's Fill and Finish for sealing. You may apply it to all surfaces except for the hinge and the hinge support. They **must remain unfilled and unpainted**. After you apply the sealer and sand the landing gears smooth you can paint them. Paint the gear International Orange or red. Paint the control cylinders and landing pads silver.

BREAK TIME!!

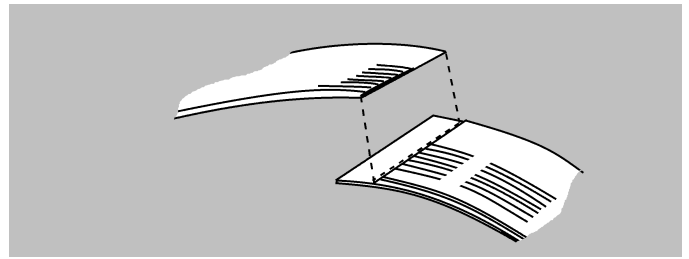

❑ **44.** Set the small end of the engine shroud down on a piece of wax paper. Insert the small nozzle spacing ring (20) and slide it down until it is flush with the bottom of the shroud. Make sure the engine hook notch is centered on the shroud joint. Run a bead of glue around the ring shroud joint and allow to dry.

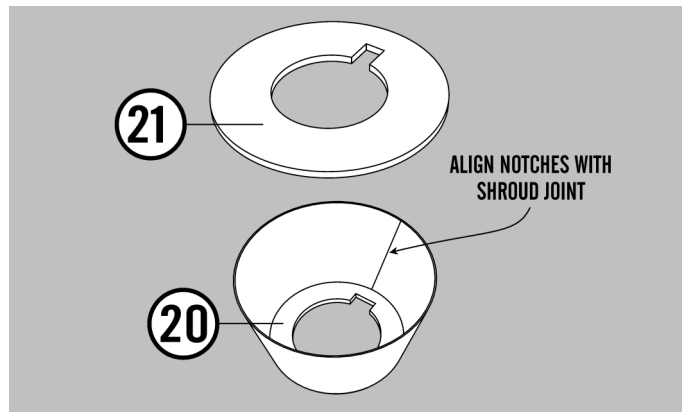

❑ **45.** Run a bead of glue around the inside of the large opening in the shroud. Place the large nozzle spacing ring (21) in the shroud and glue it into place. Make sure that the engine hook notches are in line with each other.

❑ **46.** Next trim off the last 1/4" of each landing gear opening in the descent body tube. Then slide the entire landing gear assembly into the rear of the descent stage. The aft bulkhead should be 1/16" inward from the rear of the body tube. Align so that the landing gears can move freely. Without moving the bulkhead mark each exposed section of the internal ring. The marks should be at the inside edge of each gear housing. The landing gear are not shown in the illustration below.

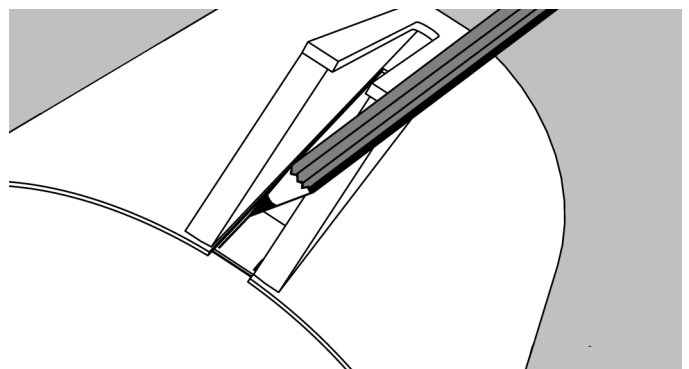

- ❑ **40.** Apply glue to the inside edge of the large end of the ascent module shroud. Center the narrow bulkhead notch over the notched brace and glue bulkhead in first with the ring facing out. Push it into the assembly until it stops. **DO NOT FORCE IT!** Make sure it is even all the way around the end of the shroud.

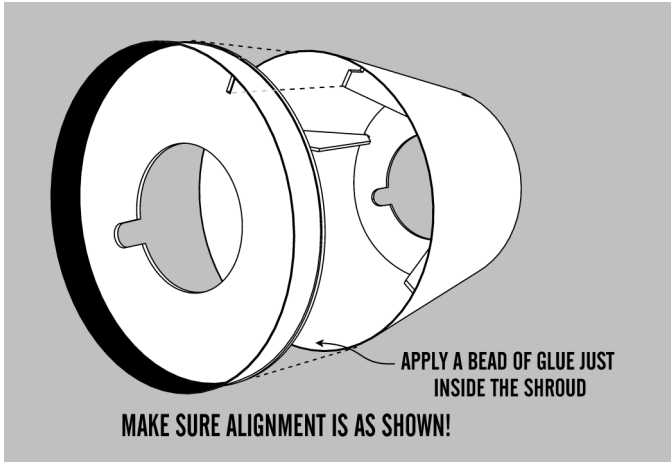

- ❑ **41.** Next pre-form the descent stage shroud in the same way as before. Put glue on the tab and press and hold into place until it sets then allow to dry completely.

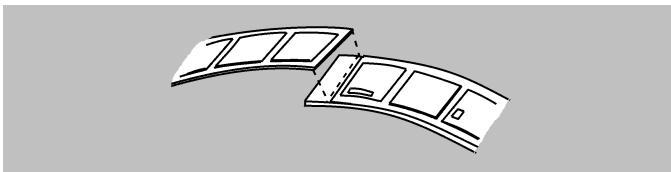

- ❑ **42.** Put a piece of wax paper on a flat surface and set the smaller end of the descent shroud on the paper. Then slide the descent stage bulkhead into the shroud until it is even with the bottom. Glue the bulkhead into place.

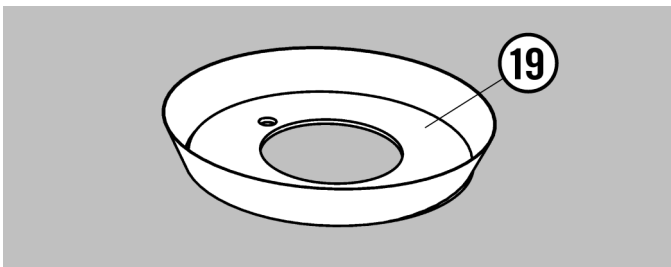

- ❑ **43.** Form the engine nozzle shroud the same as in step #34. Apply glue to the overhang and press in position and hold until it sets. Then allow the glue to dry.

ENGINE MOUNT

- ❑ **20.** Cut out the marking guide for the engine mount from the pattern sheet provided. Wrap the guide around the tube and center it. Using masking tape to hold the guide in place, mark the tube at each of the arrow points. After all marks are complete, slide the marking guide off the tube. With a straight edge draw a line passing over each mark front and rear. On the letter (A) marks draw a line down the entire length of the tube. This line will be used to align the engine hook and several rings later.

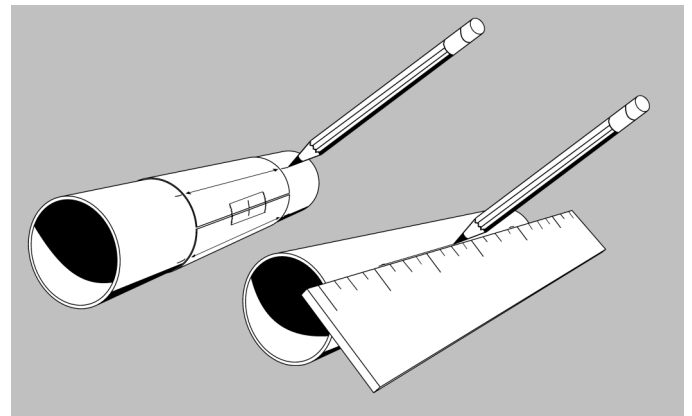

- ❑ **21.** Cut a 1/8" wide slit in the engine tube on the (A) line 1-1/2" from the top end. Insert the engine hook into the slit and glue it in place centering it over the (A) line. Only glue it up to 1" from the slit. Hold the engine hook temporarily with masking tape until it dries.

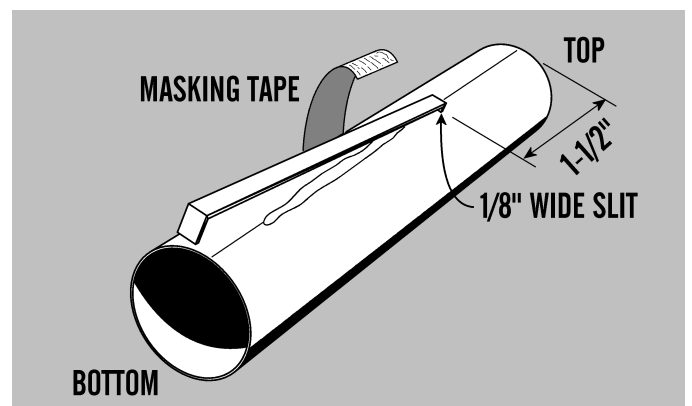

❑ **22.** Now mark the tube 1" from the rear as shown in the illustration below. Cut a notch on the inside of the engine tube centering ring 1/32" deep and 3/32" wide. Run a line of glue around the tube at the mark that you made 1" from the end and slide the centering ring on with the notch over the engine hook.

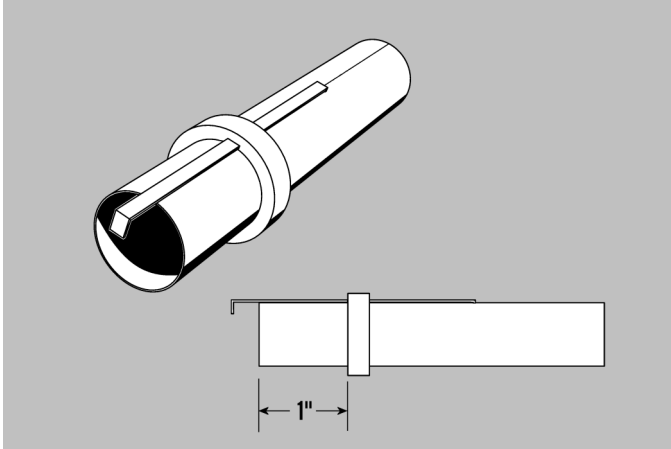

❑ **23.** Mark the opposite end of the tube at exactly 1-1/4" and 1/2" from the top end. These marks need to be in line with the (A) line that goes all the way down the tube. Using the notch in the centering ring as a alignment guide slide one of the rings (10) down to the 1-1/4" mark and apply fillets to both sides. Repeat with the other ring (10) glued even with the 1/2" mark. Make sure both notches in the rings are lined up with the line on the tube as shown. Then slide the cap ring (11) onto the end of the tube aligning the small hole over the (A) line. It must be glued **flush** with the end of the tube.

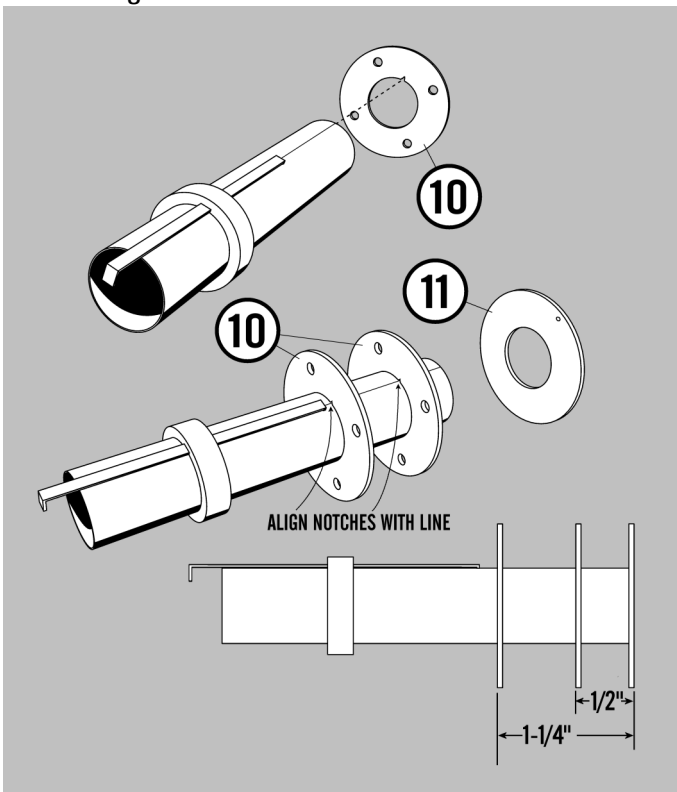

❑ **38.** On a flat surface lay a piece of wax paper down. Position the small end of the ascent module shroud on the paper. Position the forward bulkhead (16) **exactly** as shown. Make note of the position of the notched piece in the diagram. Slide the bulkhead into the bottom of the unit until it is even with the end and flat against the wax paper. Run a glue fillet around the inside of the ring to attach it to the shroud and allow it to set. Then run a line of glue along the longest edge of an ascent brace (17). Too much glue on the shrouds will cause them to buckle. Position it into one of the notches in the ring and glue it into place. Repeat with the other ascent brace.

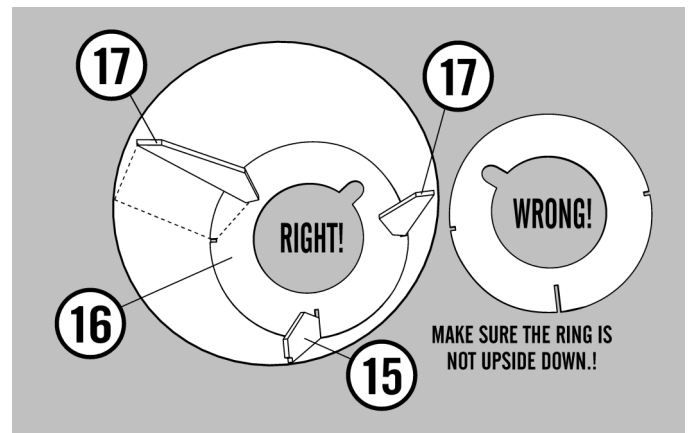

❑ **39.** Punch out the ascent module's aft bulkhead (18). Place it on a flat surface and run a bead of glue around the outside of the bulkhead and center the internal ring (RT-99D) on it and glue into place. Let dry completely.

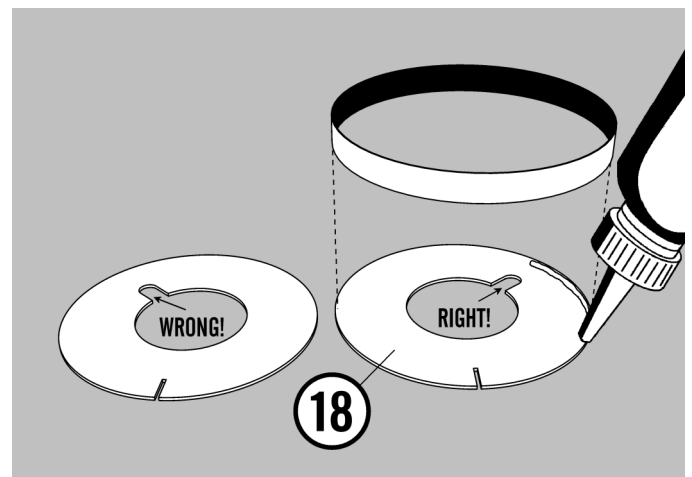

- ❑ **35.** Glue the shroud together by applying glue to the shroud tab and align the two sides together. Hold in place until it sets up and then leave to dry. White glue works best for shrouds since it does not shrink as much as some glues.

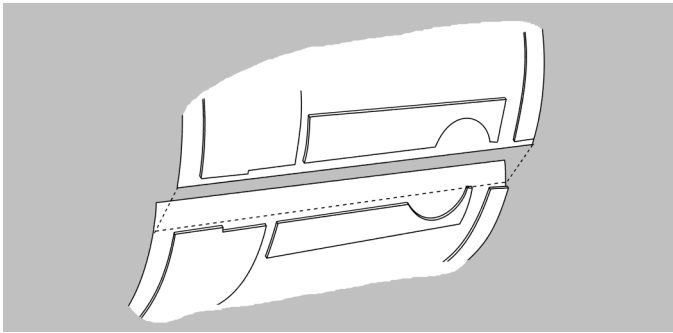

- ❑ **36.** Follow the same procedure that you just did in step 35 to the command module shroud. After the glue has set for several minutes then press the Command module bulkhead into the larger opening and glue into place. Make sure the bulkhead is even with the end of the shroud. Sanding may be necessary to get the proper fit.

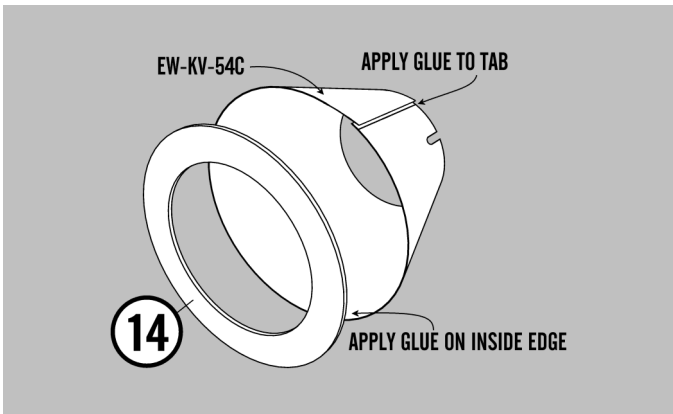

- ❑ **37.** Punch out the notched ascent module brace (15). Apply glue to the longest straight edge and glue the brace to the shroud joint so that the notched end is toward the large end of the shroud. Hold in place until it sets and make sure it points straight away from the shroud.

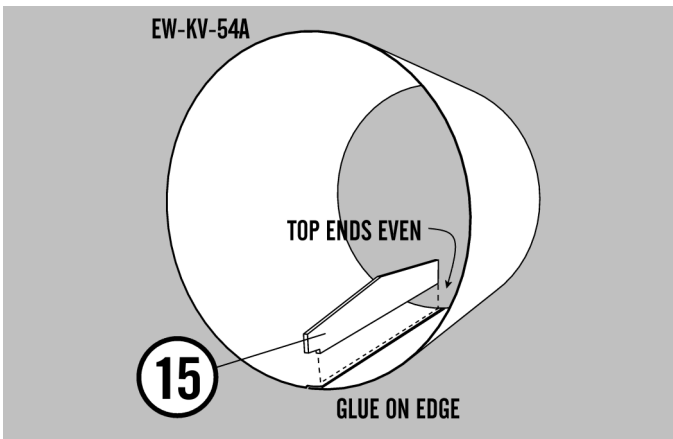

MAIN ASSEMBLY

- ❑ **24.** Punch out the balsa and paper (1) gear housing spacers. Glue the two together and let dry. Insert the spacer in between the groove in the gear housing. Wrap a piece of sandpaper around the chute tube (BT-60FG) and round the edges of the gear housing by sanding them back and forth against the tube. Do the same to the other three housings. Make sure that the bottom edges of the gear housings fit smoothly against the descent stage tube (BT-100CE.) The spacer will be discarded when you are finished with it.

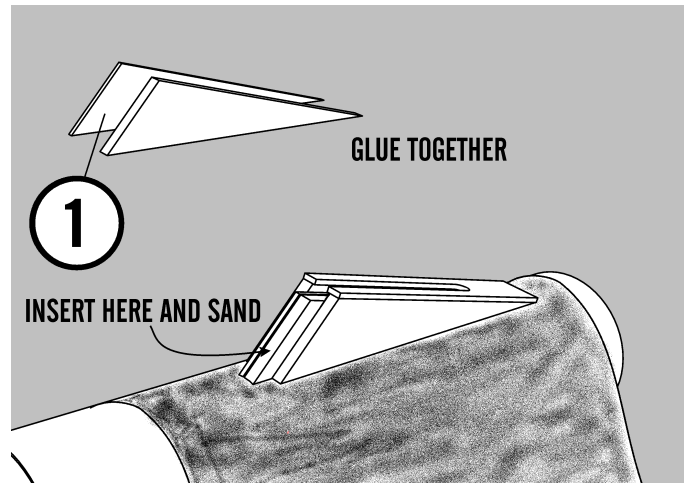

- ❑ **25.** Cut out the descent stage marking guide. Wrap the guide around the descent stage tube (BT-100CE) and tape with masking tape. Center it over the tube and mark the tube at each of the arrow points. Draw a line on the tube around each of the landing gear openings with a straight edge. Very carefully cut out the landing gear openings in the body tube except for the last 1/4" of the tube. The tube will become very flexible and hard to work with. Patience is required to avoid cutting through the large tube. (Refer to illustration)

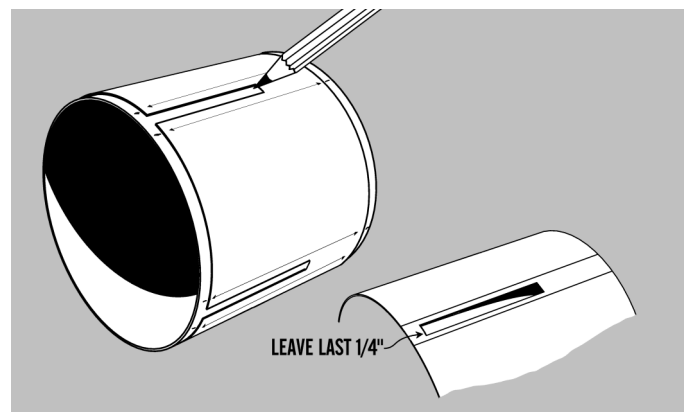

❑ **26.** Next apply a line of glue along the two longest edges of the gear housing as shown in the illustration. Glue it to the body tube so that the front of the housing is **exactly 1/8"** from the forward end of the descent tube. Also make sure that the sides of the housing are next to the alignment marks that you put on the tube. Do the same to the remaining three gear housings. Straight pins can be used to temporarily hold the assemblies in place.

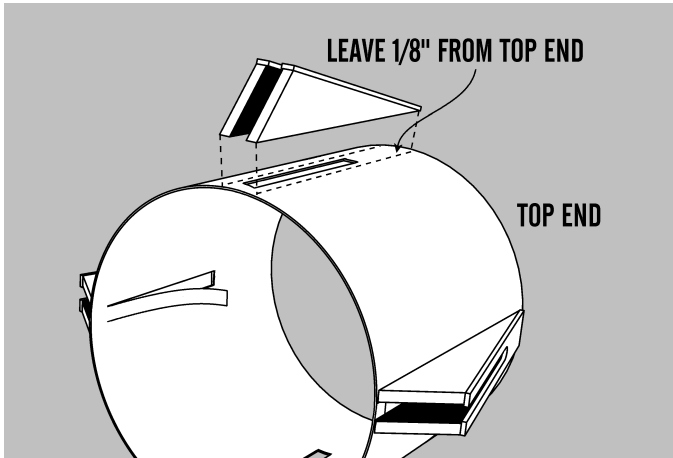

❑ **27.** Next insert one of the landing gear assemblies into the matching holes in the ring. Position the landing gear so that it points straight away from the body tube. Make sure the end of the hinge support dowel is touching the top ring (11). Apply a glue fillet to each of the joints on the rings where the landing gears come through. Glue the remaining three assemblies in the same fashion. Refer to the drawing below.

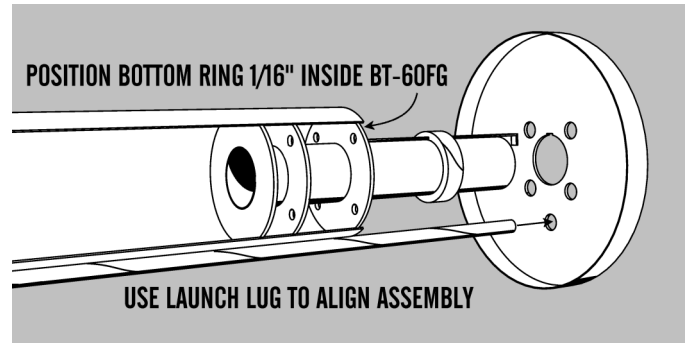
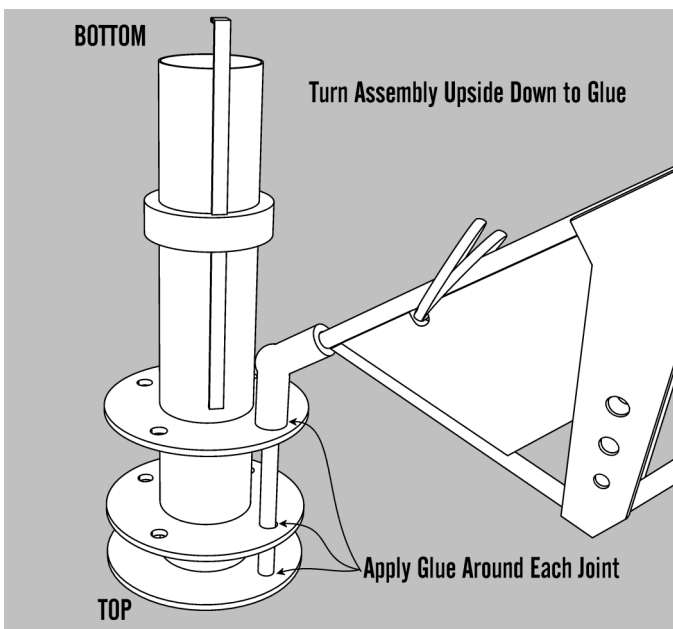

❑ **32.** Apply a line of glue around the CR-79 ring and slide the aft bulkhead assembly onto the engine mount tube. Make sure the internal ring glued to the bulkhead is forward. Push the bulkhead against the ring and allow to dry.

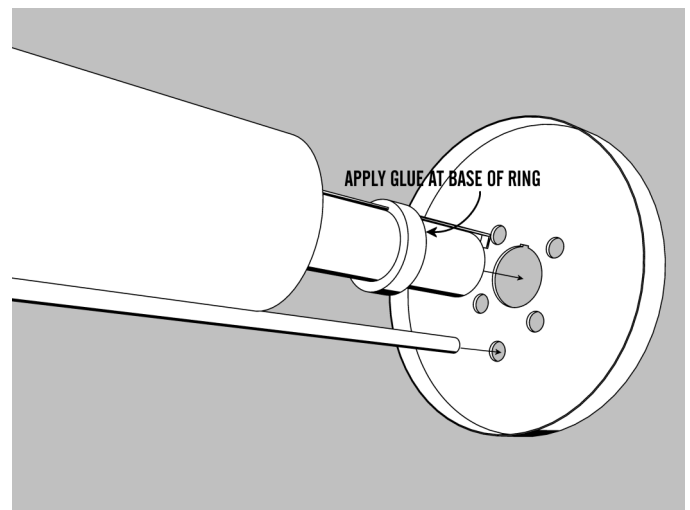

❑ **33.** Punch out the Gussets (13) and apply a line of glue to the bottom of one and the notch. Glue the gusset in place in line with one of the alignment lines that you drew on the tube earlier. Hold in place until it sets. Repeat with the other three Gussets.

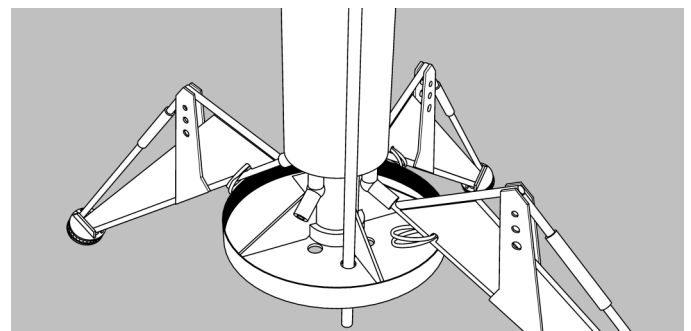

❑ **34.** Pre-form the ascent module shroud by carefully rolling into the approximate final shape. You can use a pencil or dowel to help curl it into shape, but the embossed surface is very fragile.

- ❑ **29.** Cut out the marking guide for the parachute tube and wrap it around the tube. Mark the tube at each arrow point. Remove the guide and draw a line down the whole body tube with a straight edge. Glue the long launch lug (LL-2E) on the mark you made making sure that one end of the launch lug is even with the (top) end of the tube.

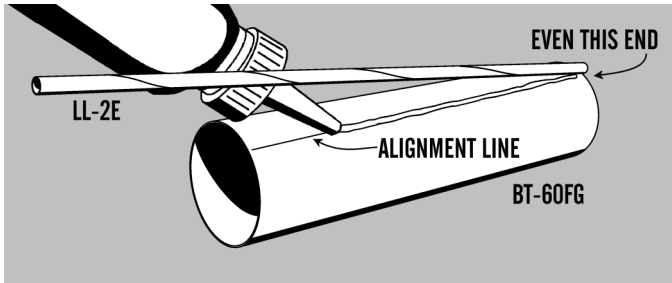

- ❑ **30.** Pass one end of the Kevlar® thread through the small hole in the Cap Ring (11) and tie it securely to the closest Hinge Support Dowel. Put a drop of glue on the knot. Pass the free end into the engine mount tube to keep it out of the way.

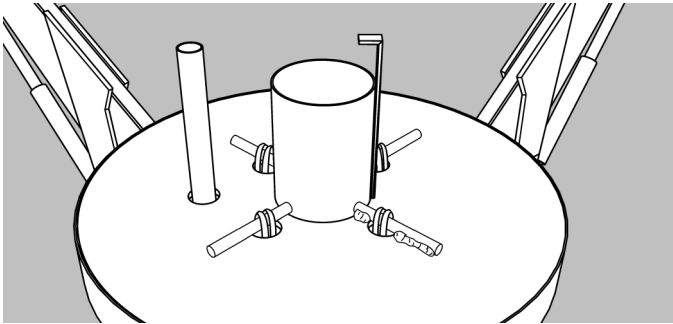

- ❑ **31.** After the glue is dry on the launch lug, slide the descent stage aft bulkhead assembly onto the rear of the engine mount tube. Center the bulkhead notch over the engine hook and slid it all the way to the centering ring. **DO NOT GLUE YET**, hold in place. Pass the launch lug through the furthest hole in the bulkhead as shown. Slide the engine mount ring assembly into the parachute tube until the bottom ring is 1/16" inside the tube. Glue the parachute tube into place.

NOTE

When the landing gears are put onto the engine tube they should look like the drawing below.

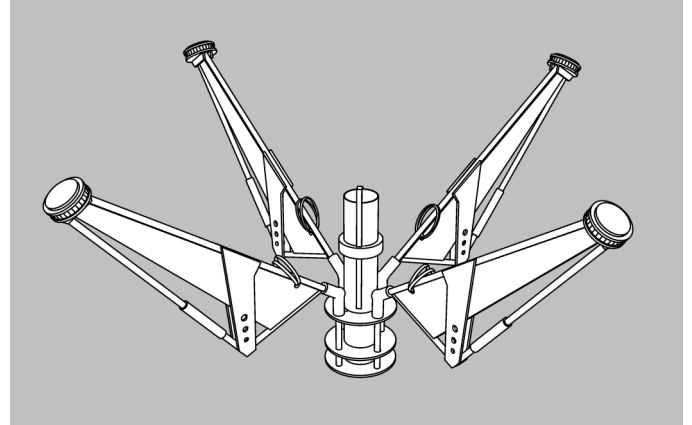

- ❑ **28.** Slide the descent stage bulkhead into the end of one of the internal body rings and glue into place by running a fillet on the inside.

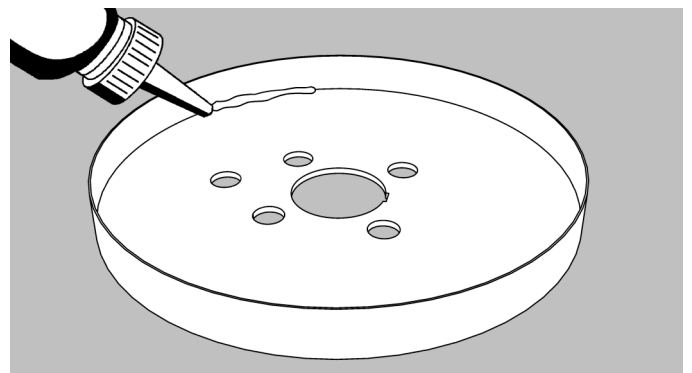
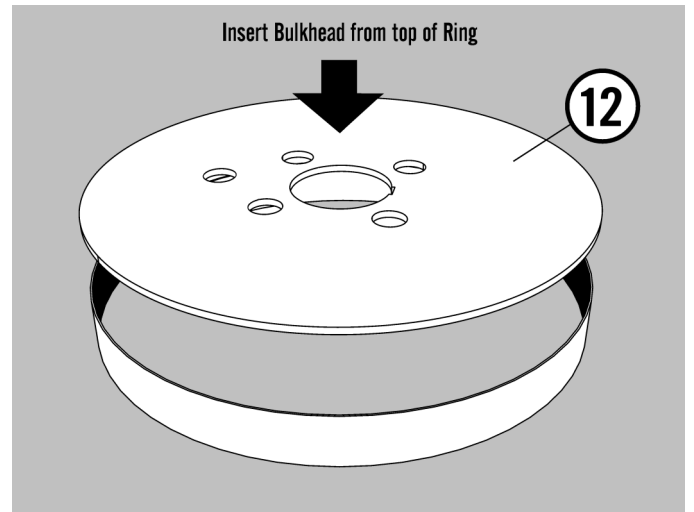

Parts List

A	1	Body Tube	BT-100CE
B	1	Body Tube.....	BT-60FG
C	1	Body Tube.....	BT-20DJ
D	2	Ring Tubes	RT-99D
E	1	Balsa Nose Cone.....	BNC-60AL
F	1	Laser Cut Fins	FV-54
G	4	Launch Lugs.....	LL-2A
H	1	Launch Lug.....	LL-2E
I	1	Wood Dowel 1/12" x 12".....	WD-112
J	4	Wood Dowels 1/8" x 12".....	WD-212
K	1	Engine Hook	EH-28
L	1	Centering Ring	CR-79
M	1	Screw Eye.....	SE-10
N	1	Elastic Cord	EC-236
O	1	Shock Cord	SCK-12
P	8	Shock Bands.....	CSB-1
Q	4	Bearings	BB-4
R	4	Engine Blocks	EB-20B
S	4	Flexible Hinges.....	PST-1A
T	1	Chute Pac 20"	CP-20R
U	1	Ascent Wrap.....	EWV-54A
V	1	Body Parts Wrap	EWV-54B
W	1	Command Wrap	EWV-54C
X	1	Descent Wrap.....	EWV-54D
Y	1	Engine Nozzle Wrap	EWV-54E
Z	1	Decal	DKV-54
AA	1	Ring Set.....	CR-KV-54A
AB	1	Ring Set.....	CR-KV-54B
AC	1	Ring Set.....	CR-KV-54C
AD	1	Pattern Sheet.....	IKV-54PS

EXPLODED VIEW

