



# Model Rocket Safety Code

- 1. Materials.** I will use only lightweight, non-metal parts for the nose, body, and fins of my rocket.
- 2. Motors.** I will use only certified, commercially-made model rocket motors, and will not tamper with these motors or use them for any purposes except those recommended by the manufacturer.
- 3. Ignition System.** I will launch my rockets with an electrical launch system and electrical motor igniters. My launch system will have a safety interlock in series with the launch switch, and will use a launch switch that returns to the "off" position when released.
- 4. Misfires.** If my rocket does not launch when I press the button of my electrical launch system, I will remove the launcher's safety interlock or disconnect its battery, and will wait 60 seconds after the last launch attempt before allowing anyone to approach the rocket.
- 5. Launch Safety.** I will use a countdown before launch, and will ensure that everyone is paying attention and is a safe distance of at least 15 feet away when I launch rockets with D motors or smaller, and 30 feet when I launch larger rockets. If I am uncertain about the safety or stability of an untested rocket, I will check the stability before flight and will fly it only after warning spectators and clearing them away to a safe distance.
- 6. Launcher.** I will launch my rocket from a launch rod, tower, or rail that is pointed to within 30 degrees of the vertical to ensure that the rocket flies nearly straight up, and I will use a blast deflector to prevent the motor's exhaust from hitting the ground. To prevent accidental eye injury, I will place launchers so that the end of the launch rod is above eye level or will cap the end of the rod when it is not in use.
- 7. Size.** My model rocket will not weigh more than 1,500 grams (53 ounces) at liftoff and will not contain more than 125 grams (4.4 ounces) of propellant or 320 N-sec (71.9 pound-seconds) of total impulse. If my model rocket weighs more than one pound (453 grams) at liftoff or has more than four ounces (113 grams) of propellant, I will check and comply with Federal Aviation Administration regulations before flying.
- 8. Flight Safety.** I will not launch my rocket at targets, into clouds, or near airplanes, and will not put any flammable or explosive payload in my rocket.
- 9. Launch Site.** I will launch my rocket outdoors, in an open area at least as large as shown in the accompanying table, and in safe weather conditions with wind speeds no greater than 20 miles per hour. I will ensure that there is no dry grass close to the launch pad, and that the launch site does not present risk of grass fires.
- 10. Recovery System.** I will use a recovery system such as a streamer or parachute in my rocket so that it returns safely and undamaged and can be flown again, and I will use only flame-resistant or fireproof recovery system wadding in my rocket.
- 11. Recovery Safety.** I will not attempt to recover my rocket from power lines, tall trees, or other dangerous places.

## LAUNCH SITE DIMENSIONS

Installed Total Impulse (N-sec)	Equivalent Motor Type	Minimum Site Dimensions (ft.)
0.00 — 1.25	1/4A	50
1.26 — 2.50	A	100
2.51 — 5.00	B	200
5.01 — 10.00	C	400
10.01 — 20.00	D	500
20.01 — 40.00	E	1000
40.01 — 80.00	F	1000
80.01 — 160.00	G	1000
160.01 — 320.00	2 Gs	1500

**SEMROC**  
**"HUSTLER"**

**OVER THREE FEET TALL!**  
**SINGLE STAGE PAYLOAD**  
**RUGGED CONSTRUCTION**

Smooth precision-sanded balsa nose cone and coupler

Laser-cut basswood fins

24" Diameter 1.9 oz.  
 Rip-Stop Nylon Chute

Laser-slotted thick-walled tube

24 mm engine mount  
 29 mm optional

1965  
 with Repto

**FLYING MODEL ROCKET KIT**

**FLIES ON D - G ENGINES!**

**SEMROC**

Made in the U.S.A by Semroc Astronautics Corporation - Knightdale, N.C. 27545

## SLS Hustler Kit No. KV-11

Specifications	Engine	Approx. Altitude
Body Diameter 1.84" (4.7cm)	D15T-4	450'
Capsule Diameter 2.34" (5.9cm)	E15W-4	1100'
Length 39.7" (100.8cm)	F24W-7	1400'
Fin Span 11.8" (30.0cm)		
Net Weight 9.0 oz. (255.2g)		

## NYLON PARACHUTE RECOVERY

## What is a Retro-Repro™?

A retro-repro is a retro reproduction of an out-of-production model rocket kit. It is a close approximation of a full scale model of an early historically significant model rocket kit from one of the many companies that pioneered the hobby over the past half century. A retro-repro is not a true clone or identical copy of the original. It incorporates improvements using modern technology, while keeping the flavor and build appeal of the early kits.

---

## What is SLS?

SLS is short for Semroc Large-Scale Rocketry. Based on the original Centuri Large Scale Line using larger, thicker-walled body tubes, Semroc is introducing several models in the Mid-Power range. Most of the models will fly on 24mm and 29mm engines in the C through G (and small H) impulse levels. Featured in the family are laser-cut basswood fins, Nylon chutes, and laser-slotted tubes allowing much more robust construction designed to last for years of flying.

---

## About

### Centuri Engineering Company

Centuri Engineering Company was started in 1961 by Leroy (Lee) Piester in his garage while he was still in college in Phoenix, Arizona. With his wife, Betty, they built Centuri into one of the largest model rocket companies ever.

Centuri was known for its unusual and innovative designs, producing over 140 different kits with something for every model rocketeer. They also produced model rocket engines and pioneered the modern composite high powered engines with their Enerjet line.

Centuri Engineering was sold to Damon in the late 1960's and shared the same parent corporation with Estes Industries, the largest model rocket company in the world. The Centuri product line was kept separate from the Estes line until 1983. A few of the old kits have been reissued by Estes since then, but for the most part, Centuri Engineering Company lives today only in the dreams of the senior members of the model rocket community.

---

July 8, 2006

Copyright © 2006 Semroc Astronautics Corporation  
Box 1271 Knightdale, NC 27545 (919) 266-1977

## LIMITATION OF LIABILITY

Model rockets are not toys, but are functional rockets made of lightweight materials and are launched with NAR or Tripoli safety certified model rocket motors, electrically ignited and flown in accordance with the NAR Model Rocket Safety Code. If misused, model rockets can cause serious injury and property damage. Semroc certifies that it has exercised reasonable diligence in the design and manufacture of its products. Semroc cannot assume any liability for the storage, transportation, or usage of its products. Semroc shall not be held responsible for any personal injury or property damage whatsoever arising out of the handling, storage, use, or misuse of our products. The buyer assumes all risks and liabilities therefrom and accepts and uses Semroc products on these conditions.

Your purchase and use of any Semroc products is construed as your agreement to and acceptance of these terms. If you do not agree to these terms and conditions, you must return the product, unused, for refund or credit.

## 100% SATISFACTION GUARANTEE

If you are not 100% satisfied with your Semroc product, we will make it right by providing whatever you consider fair, from refund to replacement.

Contact us at:

**Semroc Astronautics Corporation**

Customer Service Department  
P.O. Box 1271  
Knightdale, North Carolina 27545

## JOIN THE NAR!

Sign up online at [www.nar.org](http://www.nar.org) to join the premier model rocketry organization. Semroc fully supports the National Association of Rocketry and recognizes it as the sport's official voice. The NAR is the oldest and largest sport rocketry organization in the world. Since 1957 over 80,000 serious sport rocket modelers have joined the NAR to take advantage of the fun and excitement of organized rocketry. It is always more fun if you fly with friends. The *Sport Rocketry* magazine is one of the best ways to keep informed of new developments in the hobby. Check online at [www.semroc.com/nar](http://www.semroc.com/nar) for promotions just for NAR members.



# MORE ENGINE MOUNTS FOR YOUR SLS HUSTLER!

Additional engine mounts are available for your SLS Hustler for even more fun! The 29mm RMS mount will accept standard Aerotech® RMS-29/40-120 or RMS-29/60 motors. Other mounts will be available in the future. All the mounts are interchangeable between the LT-175 based kits with four fins.

## 29mm RMS

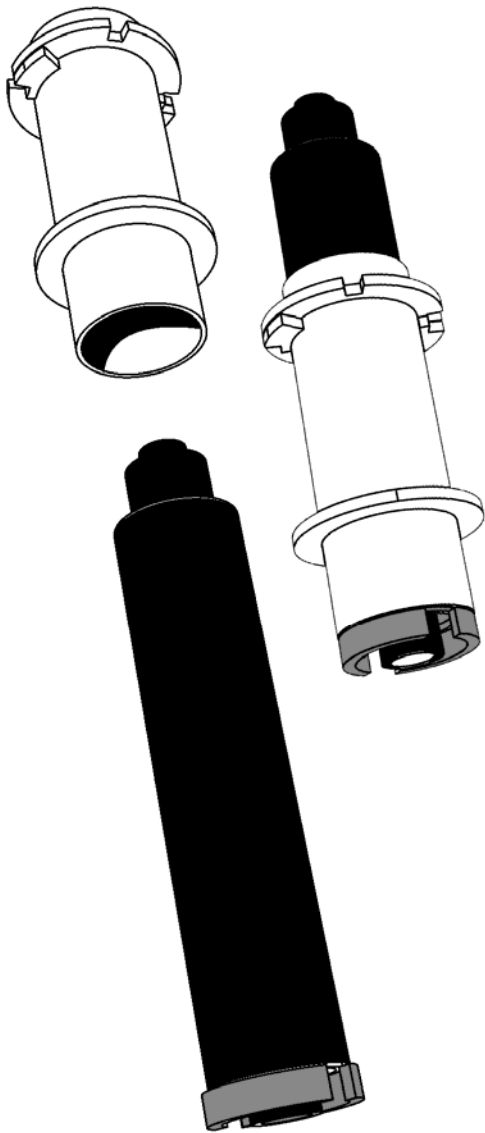

## About the SLS Hustler™

The Centuri Hustler Carrier Rocket was introduced in the 1965 Catalog as a member of the Centuri Large Scale Series. It was shipped with 3 Hercules Port Burning F15-4 engines. It was originally released as Centuri #KF-10 and was shipped via Railway Express since it included engines that could not be shipped Parcel Post. The initial price was \$14.95 including engines. In 1969 it was offered as a kit only with part # KF-10a for \$11.50 and included Parcel Post shipping. The Hustler was the largest of the Centuri Large Scale Series.

The Retro-Repro SLS Hustler is updated with precision two-part laser-cut basswood fins instead of the hard balsa pre-printed fins used on the original. The Sil-Ray cloth fin reinforcement is replaced by a slotted tube and through-the-wall fins. The original Hustler had a wire shock cord mount which is replaced with an ejection baffle with Kevlar® cord for greater reliability. A removable 24mm engine mount adapter is included and several other removable 29mm mounts are offered as options to increase the selection of engines that can be used.

## BEFORE YOU START!

Make sure you have all the parts included in this kit that are listed in the Parts List in the center of these instructions. In addition to the parts included in this kit, you will also need the tools and materials listed below. Read the entire instructions before beginning to assemble your rocket. When you are thoroughly familiar with these instructions, begin construction. Read each step and study the accompanying drawings. Check off each step as it is completed. In each step, test-fit the parts together before applying any glue. It is sometimes necessary to sand lightly or build-up some parts to obtain a precision fit. If you are uncertain of the location of some parts, refer to the exploded view in the center of these instructions. It is important that you always ensure that you have adequate glue joints.

**TOOLS:** In addition to the parts supplied, you will need the following tools to assemble and finish this kit. Wax paper and masking tape are also required.



White  
Glue or  
Wood  
Glue

Spray  
Paint

Fill 'N  
Finish  
or Sanding  
Sealer

Fine Sandpaper  
320 to 600 grit

Ruler

Hobby  
Knife

Pencil

# ASSEMBLY

- ❑ **1.** These instructions are presented in a logical order to help you put your SLS Hustler™ together quickly and efficiently. Check off each step as you complete it and we hope you enjoy putting this kit together and flying it.

## ENGINE MOUNT

- ❑ **2.** Carefully remove the plywood rings and stops from the laser-cut sheet. Lightly sand any small hold-in tabs. Align the pieces for the upper ring as shown below. Glue the stops EXACTLY as shown for proper operation of the twist lock mount. Wipe any excess glue from the inside and outside edges of the ring.

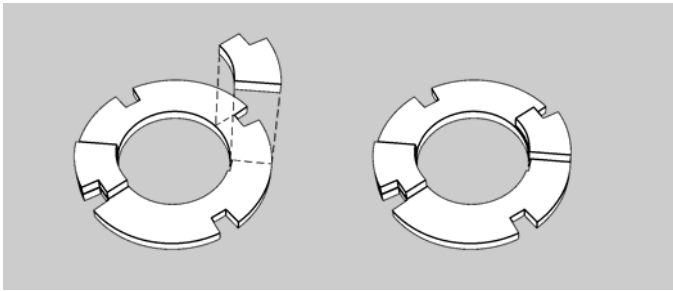

- ❑ **3.** Slightly bow the engine hook outward at the middle. Insert one end into the pre-punched hole in the engine mount tube. Apply a small bead of glue in the top of the engine mount tube and slide the thrust ring until it just touches the end of the engine hook.

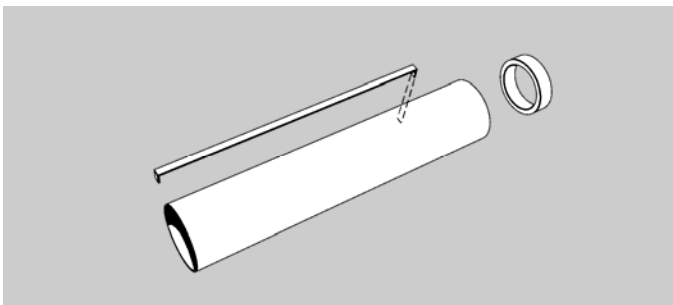

- ❑ **4.** Apply a small amount of glue around the end of the hook where it goes into the tube.

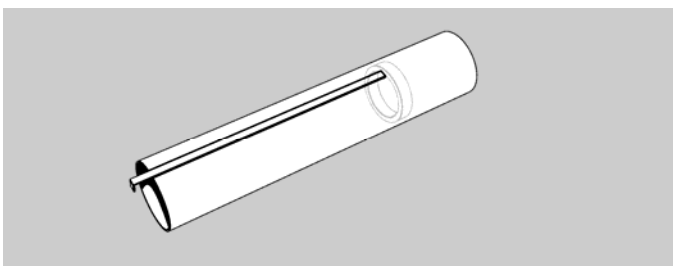

- ❑ **35.** After the paint has dried, decals should be applied. The decals supplied with the SLS Hustler are waterslide decals. Add a drop of detergent to the water to make the decals easier to slide into place. Each decal should be cut separately from the sheet. The roll bars are a challenge to get aligned so be patient and keep the decal wet until it is in the proper place.



## FLIGHT PREPPING

- ❑ **36.** The included engine mount is designed for a 24mm engine. Use the spacer for 2.75" engines (D) and leave it out for 3.75" engines (E). Twist the engine mount into the end of the SLS Hustler. It should turn about 45 degrees and lock.

- ❑ **37.** The SLS Hustler has an Ejection Baffle to help protect the Nylon chute from the hot gasses. The use of recovery wadding will provide additional insurance. Pack the recovery wadding from the top of the body tube. Use a sufficient quantity to protect the parachute, but not too much that there is no room left.

- ❑ **38.** Fold the parachute and pack it and the shock cord on top of the recovery wadding. Slide the upper section into place, making sure it does not pinch the shock cord or parachute.

- ❑ **39.** Refer to the model rocket engine manufacturer's instructions to complete the engine prepping. Different engines have different igniters and methods of hooking them up to the launch controllers.

- ❑ **40.** Carefully check all parts of your rocket before each flight as a part of your pre-flight checklist. Launch the SLS Hustler from a 3/16" diameter by 48" long or longer launch rod.

- ❑ **41.** After each flight, remove the engine mount and clean it thoroughly for many hours of fun flying with your SLS Hustler!

# FINISHING

- ❑ **32.** When the fillets have dried, prepare balsa and basswood surfaces for a smooth professional looking finish. Fill the wood grain with diluted Fill n' Finish or sanding sealer. When dry, sand with fine sandpaper. Repeat until smooth.

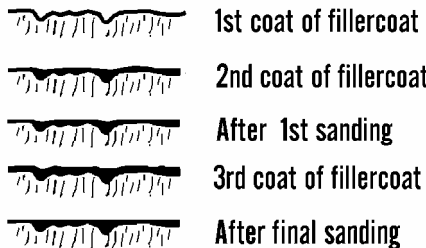

- ❑ **33.** After all balsa and basswood surfaces have been prepared, wipe off all dust with a dry cloth. First spray the model with an enamel primer. Choose a high visibility color combination like white and orange for the final color.

- ❑ **34.** Spray painting your model with a fast-drying enamel will produce the best results. PATIENCE...is the most important ingredient. Use several thin coats, allowing each coat to completely dry before the next coat. Start each spray a few inches above the model and end a few inches below the model. Keep the can about 12" away and use quick light coats. The final coat can be a little heavier to give the model a glossy wet-looking finish.

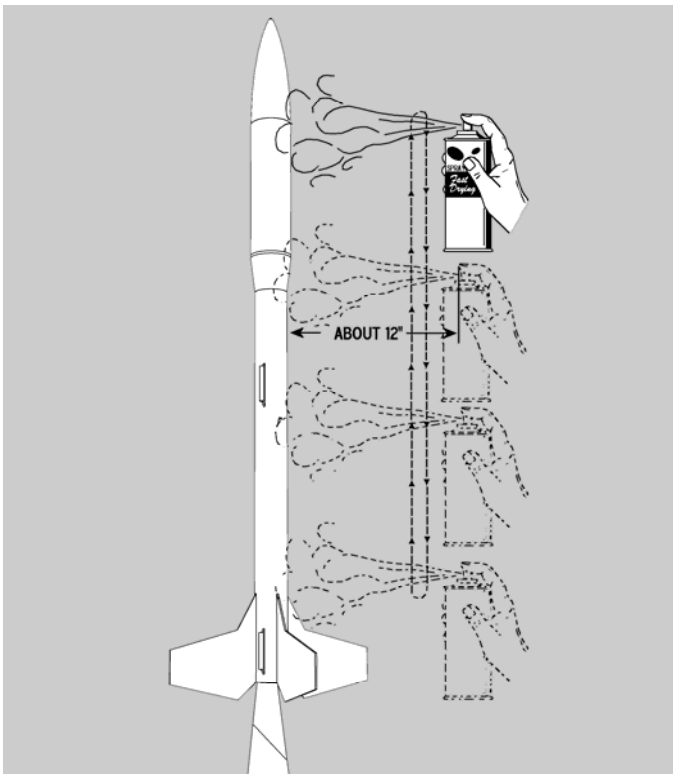

- ❑ **5.** Orient the engine mount assembly as shown. Place one mark at 1" from the rear end of the tube as shown. Place another mark 2" from the first mark. Slide the top ring assembly from the top of the engine mount tube until it almost touches the 2" mark. Slide the bottom ring over the engine hook and tube until it almost touches the 1" mark. There should be just over 2" between the two rings and they should be perpendicular to the engine mount tube. **If the rings are closer than 2", they will not mount properly in the main tube.**

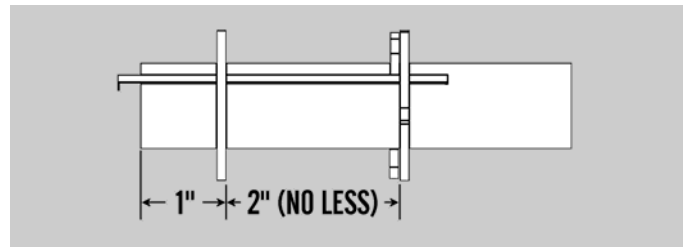

- ❑ **6.** Apply fillets of glue around all the joints between the tube and the plywood rings. Don't make the fillets too large or the mount will be hard to operate later. Wrap a piece of masking tape around the tube halfway between the two rings. Apply a bead of glue along the engine hook from the masking tape to the upper ring. Leave glue off the lower end of the hook.

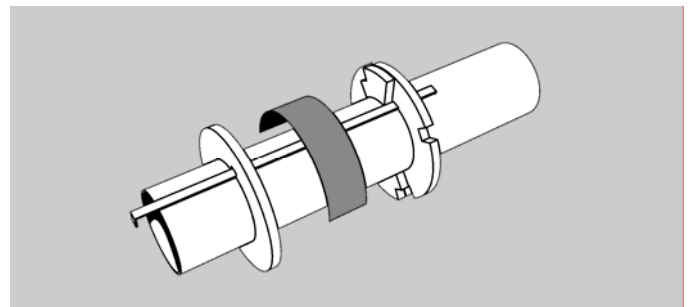

- ❑ **7.** This completes the assembly of the 24mm motor mount. Set it aside and allow all glue to dry completely.

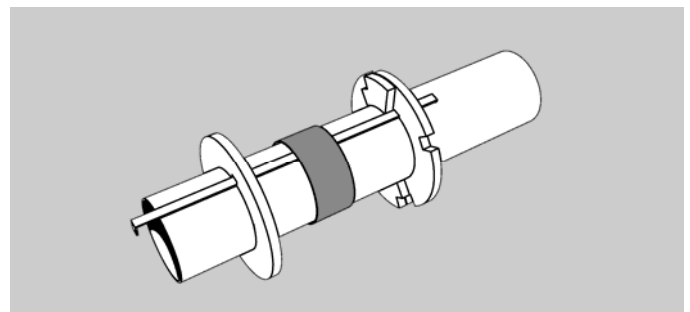

## EJECTION BAFFLE

- ❑ **8.** Using a ruler, straight edge, or door jam, place a straight line on one of the two baffle tubes. Place a mark on the line 1/2" from the end as shown.

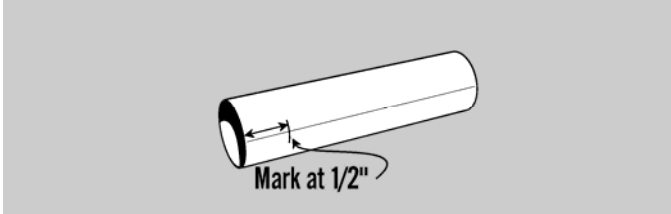

- ❑ **9.** Apply a bead of glue along the marked line from the 1/2" mark to the far end. With both tubes on a flat surface, slide the second tube against the bead of glue and hold in place until the glue sets.

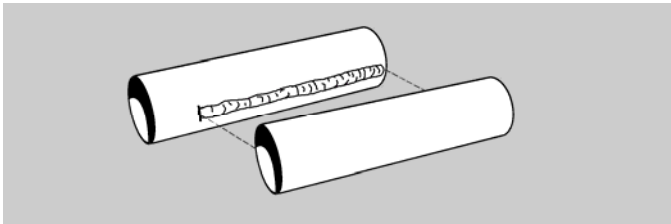

- ❑ **10.** After the glue is dry, apply additional fillets along both sides of the tube joints for strength. Since these tubes will absorb much of the heat of the ejection gases, apply a generous coating to the inside and outside of both tubes. Allow this assembly to dry.

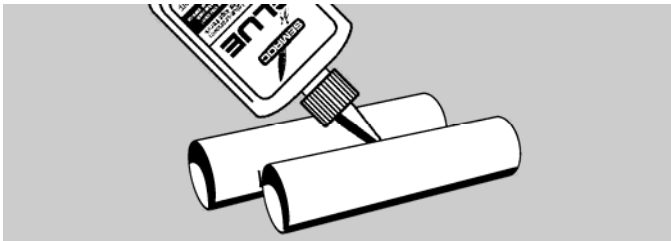

- ❑ **11.** Tie a large knot in one end of the Kevlar® cord. Thread it in the small notch in one of the baffle rings as shown.

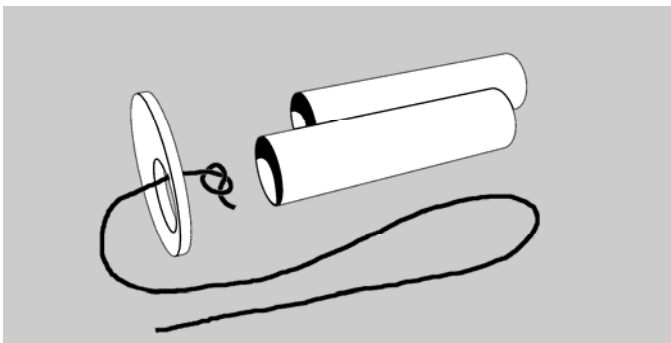

- ❑ **30.** Insert the nose cone into the large body tube and check for fit. A small amount of sanding may be necessary. Make sure it is tightly fitted using masking tape if necessary. If a payload is added, screws or external tape may be required to secure the nose cone in flight.

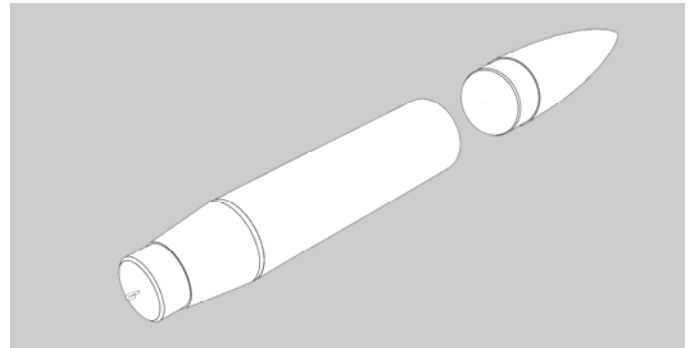

## ATTACH PARACHUTE

- ❑ **31.** Tie the free end of the elastic cord securely to the screw eye in the balsa reducer. Attach the pre-assembled Nylon chute to the screw eye. Make sure all the lines are the same length. A snap swivel may be used to make detachment easier.

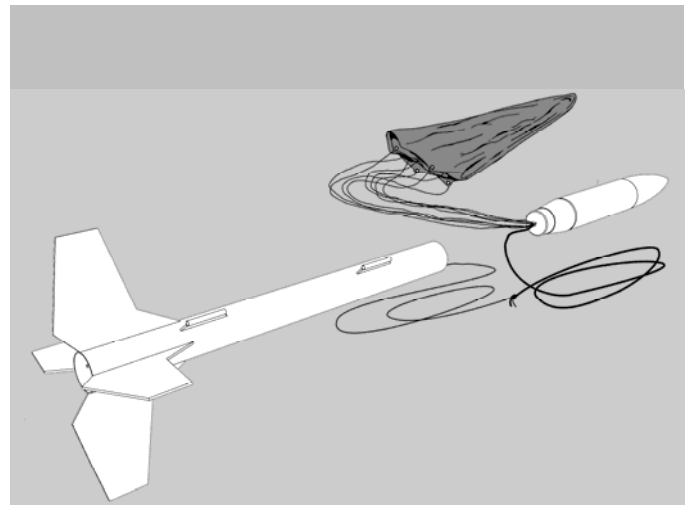

*This completes the  
assembly of your*

**SEMROC**  
**"HUSTLER"**

- ❑ **27.** Glue the bottom launch lug assembly midway between two of the main fins and about 1/4" from the bottom of the main body tube. Glue the upper launch lug assembly in line with the bottom lug and about 2" from the top of the tube. Sight down the tube to insure the launch lugs are parallel with the fins and in line with each other. Apply a bead of glue along the sides of both launch lug standoffs.

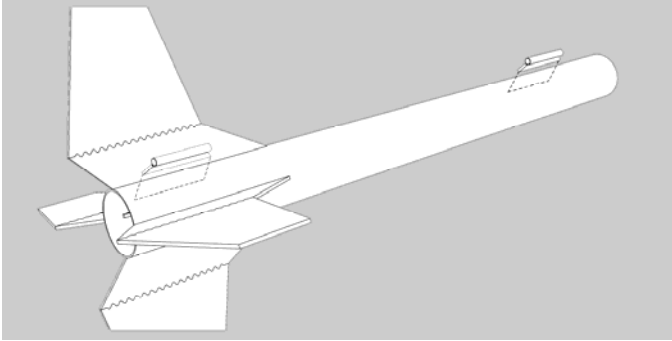

## ASSEMBLE PAYLOAD

- ❑ **28.** Twist the screw eye into the center of the smaller end of the reducer. Unscrew it and squirt glue into the hole. Reinstall the screw eye and wipe off any excess glue.

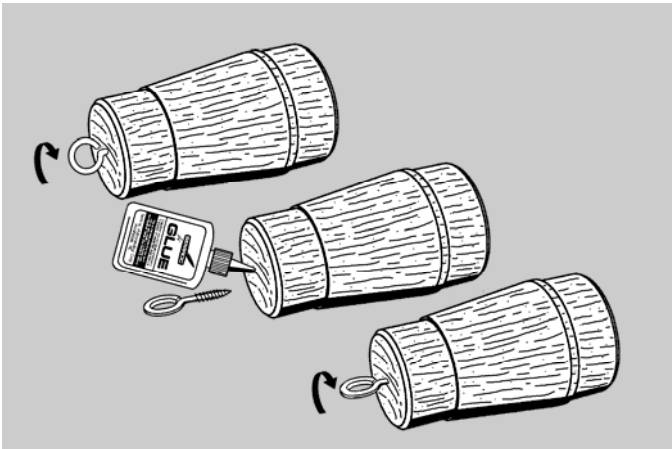

- ❑ **29.** Check the balsa adapter for fit in the upper body tube and the lower body tube. A small amount of sanding may be necessary. Spread a small amount of glue on the inside of the upper body tube. Insert the balsa adapter until it seats even with the shoulder. Allow to dry.

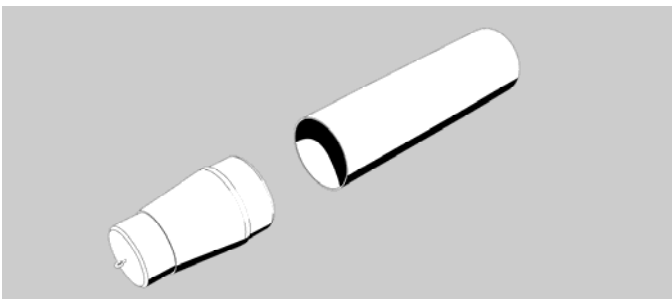

- ❑ **12.** Slide the ring with the cord over one end of the baffle tube leaving about 1/16" showing. Make sure the Kevlar® cord is captured. **Do not glue yet!**

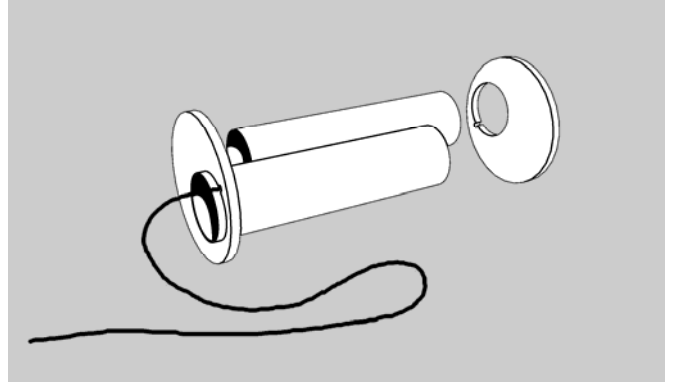

- ❑ **13.** Slide the second ring over the opposite end of the assembly. Align the two rings so the assembly is symmetrical and rolls smoothly over the table. When the assembly is aligned, apply fillets of glue over both sides of each ring along the tube joints. Keep glue off the outside surface of each ring. Roll up the cord and place it inside the top tube so it is out of the way later.

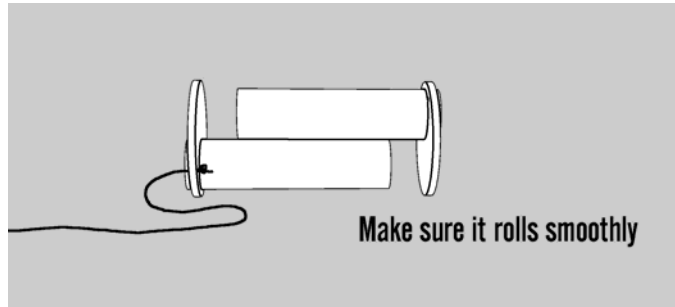

## FIN PREPARATION

- ❑ **14.** The SLS Hustler fins are made in two interlocking pieces for added strength. Using a piece of wax paper, align the first set as shown. The two pieces will only fit well if they are oriented correctly. Apply a bead of glue along the wavy edge of the smaller piece. Test fit the two pieces together to get glue on both edges. Pull them apart and allow to dry for about fifteen minutes. Repeat for the other three sets. Allow the glue to get tacky for the next step. Do not allow them to dry completely.

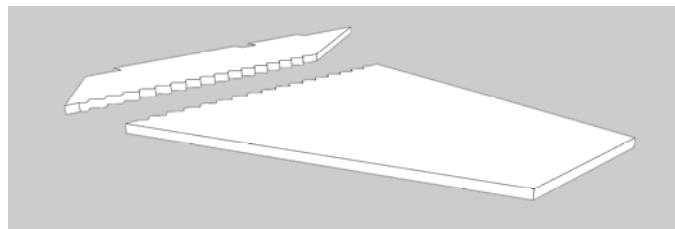

❑ **15.** Join the first set that has been drying the longest. Make sure the wax paper is on a flat surface. Hold the two pieces together until they will stay joined. Repeat for the other three sets, being careful not to disturb the completed assemblies. Wait for the glue to dry completely then remove from the wax paper.

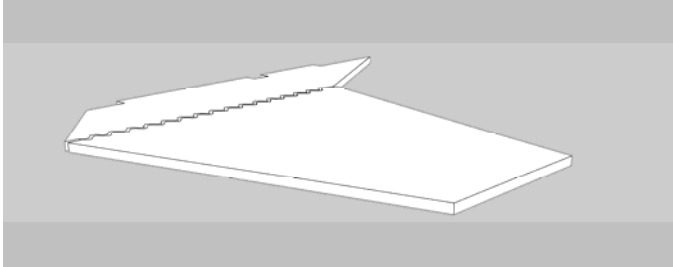

❑ **16.** When the assemblies are dry, run a thin bead of glue into each joint. Smooth each joint with your finger, using a small amount of water to make a smooth joint. Repeat on the other sides. Allow all the fin assemblies to dry.

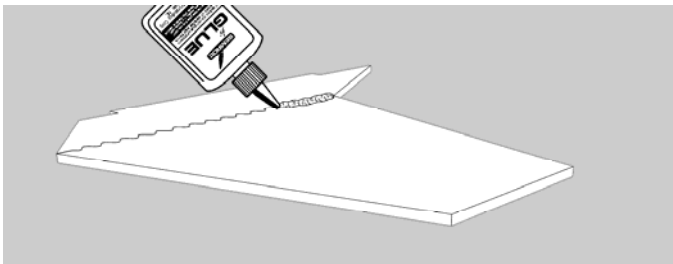

## FIN ASSEMBLY

❑ **17.** Lightly sand each side of the four fins. Round all edges except the root edges (which will be glued to the body tube). The tip edges and trailing edges may be tapered for better aerodynamic cross section.

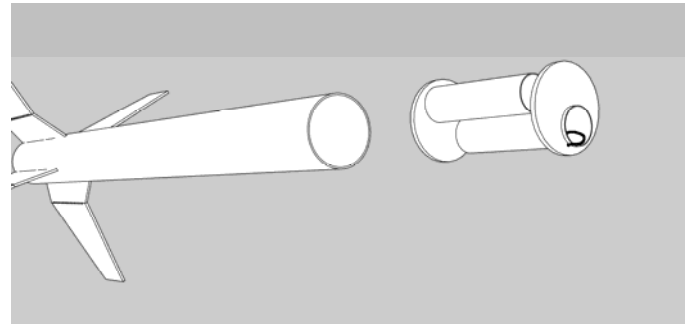
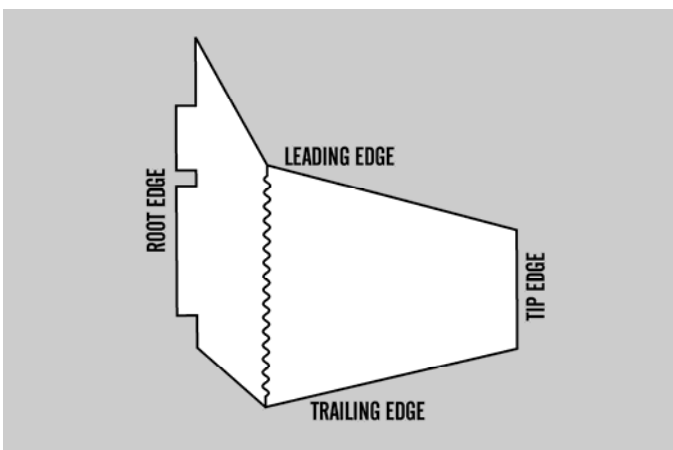

❑ **24.** Apply a generous bead of glue around the top ring of the ejection baffle using the glue applicator. Keep glue away from the Kevlar® cord. Allow to dry.

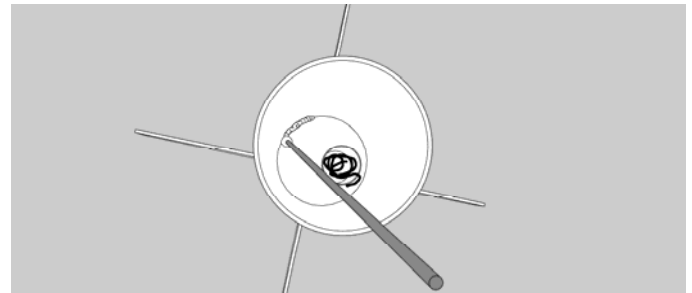

❑ **25.** Shake the Kevlar® cord out of the top of the baffle and out of the main tube. Using the long free end of the Kevlar® cord and one end of the elastic shock cord, tie an overhand knot joining the two cords. Pull the thread and cord tight leaving about 1" of excess after the knot. Put a drop of glue on the knot to keep it from coming untied.

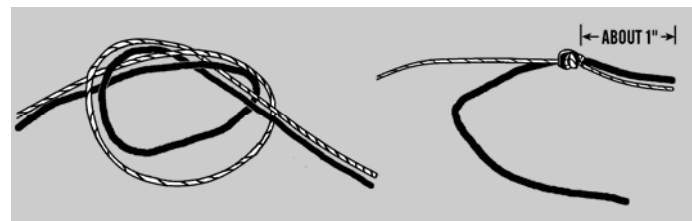

## ATTACH LAUNCH LUGS

❑ **26.** Glue one of the launch lugs to the top of one of the standoffs. After it is dry, apply a heavy fillet of glue on both sides. Repeat for the other launch lug assembly. Allow to completely dry.





- ❑ **21.** Using your finger, apply fillets of glue along the outside fin-to-body tube joints. Stand it on end, watching for runs. Allow the assembly to completely dry.

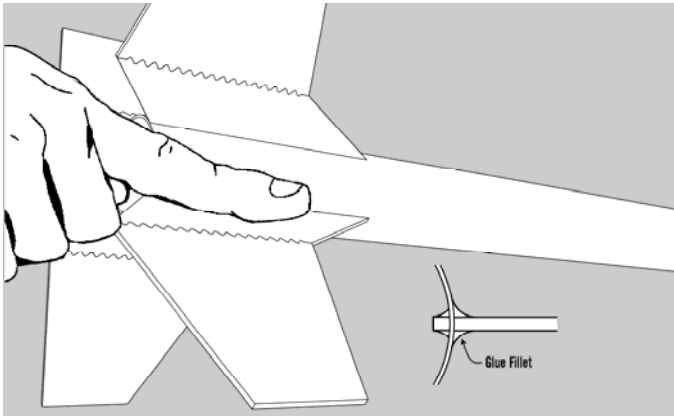

- ❑ **22.** Using the glue applicator, apply a thin bead along the fin tabs on the inside of the tube. Keep glue off the ends of the bottom fin tabs. The internal fillets provide strength to the fin joint.

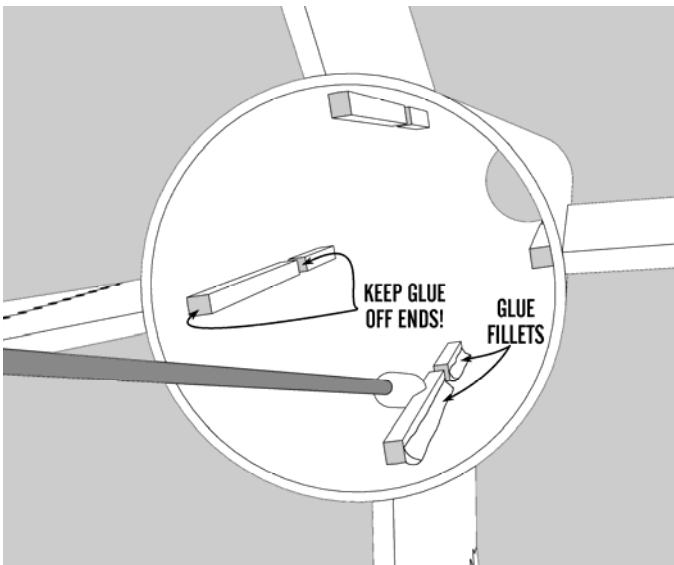

## ADD EJECTION BAFFLE

- ❑ **23.** Test fit the ejection baffle in the main tube. Sand the edges so it will slide freely in the main body tube. Apply a bead of glue about 6" inside the top of the main tube. Orient the baffle assembly so the Kevlar cord is at the top end. Slide the ejection baffle in the tube past the bead of glue until the top of the baffle is about 5-6" from the top of the tube. Rotate the main tube as the glue is drying so it does not pool in one place. Allow to dry completely.

- ❑ **18.** Check all four fin assemblies for fit in the slots in the slotted body tube. These are close tolerance so the fins will be supported well. It may be necessary to bevel the root edge slightly for easier insertion. A small piece of sandpaper or a nail file will help with the fit.

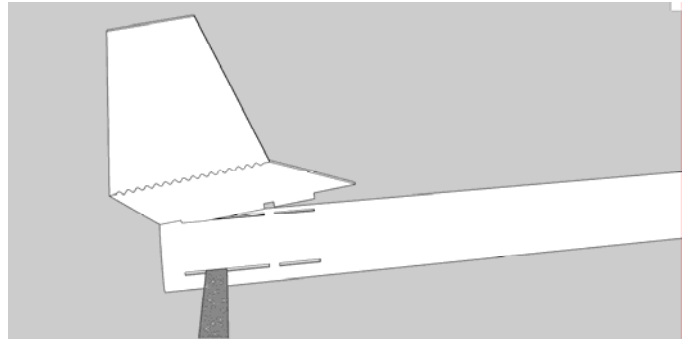

- ❑ **19.** When all four fins fit properly, apply a bead of glue along one root edge including the two tabs. Insert the fin into the slots, checking for alignment. Make sure the bottom fin tabs are free of glue on the ends. The motor mount will not work properly if too much glue remains on those surfaces. Repeat for the other fins. While the glue is setting, keep checking for proper alignment. Stand the tube on end and wipe all glue runs.

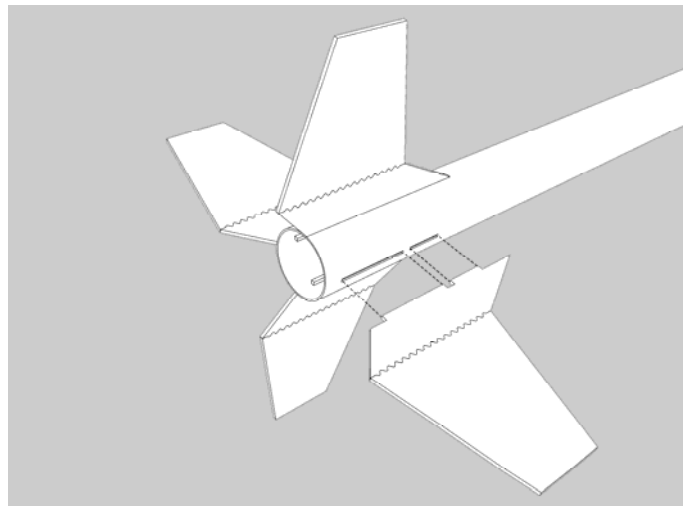

- ❑ **20.** Sight down the end of the tube and make sure all fins are at 90 degree (right) angles to adjacent fins.

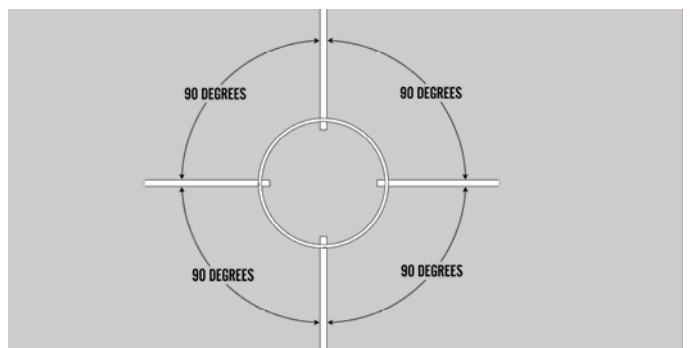

### Parts List

- A 1 Body Tube ..... LT-175220S4
- B 1 Body Tube ..... LT-22580
- C 1 Balsa Nose Cone ..... BC-22567
- D 1 Balsa Reducer ..... BR-175-225
- E 1 Laser Cut Fin Set ..... FV-11
- F 1 Screw Eye ..... SE-12
- G 2 Baffle Rings ..... EB-175P
- H 2 Baffle Tubes ..... ST-730
- I 1 Kevlar Cord ..... SCK-418
- J 1 Elastic Cord ..... ECR-236
- K 2 Launch Lugs ..... LL-320
- L 2 Launch Lug Standoffs ..... FV-11S
- M 1 Plywood Ring Set ..... CR-9-175P
- N 1 Thrust Ring ..... TR-9
- O 1 Engine Mount Tube ..... ST-950E
- P 1 Engine Hook ..... EH-38
- Q 1 Engine Spacer ..... TS-9
- R 1 24" Nylon Parachute ..... PN-24
- S 1 Decal ..... DKV-11
- T 1 Glue Applicator ..... GA-2

# EXPLODED VIEW

